



United Technologies
turn to the experts

VAV Zone II Controllers Installation and Start-up Guide





Verify that you have the most current version of this document from www.hvacpartners.com or your local Carrier office.

Important changes are listed in **Document revision history** at the end of this document.

CARRIER CORPORATION ©2019. All rights reserved throughout the world. i-Vu is a registered trademark of Carrier Corporation. All other trademarks are the property of their respective owners.

Contents

Introduction.....	1
What are VAV Zone II controllers?	1
Specifications	4
Linkage.....	6
Safety Considerations	8
Field-supplied hardware	8
Installing the VAV Zone II	9
Mounting the VAV Zone II	9
To mount the controller and actuator	9
To connect duct tubes to the flow sensors	13
Wiring the VAV Zone II for power.....	14
To wire the controller for power.....	14
Addressing the VAV Zone II	15
Wiring for communications.....	15
Wiring specifications for BACnet MS/TP and ARC156.....	16
To wire the controller to the BACnet network.....	16
Wiring devices to the VAV Zone II's Rnet port.....	17
Wiring specifications	17
To wire ZS sensors to the controller.....	17
To wire the Wireless Adapter for wireless sensors.....	18
To wire an Equipment Touch to the VAV Zone II.....	20
To wire the TruVu™ ET Display	21
Wiring sensors to the VAV Zone II's inputs	22
To wire the T55 sensor to the controller.....	23
To wire the Supply Air Temperature sensor to the controller	24
To wire the CO2 sensor to the controller	24
To wire the Relative Humidity sensor to the controller	26
Wiring a remote occupancy sensor	27
Wiring equipment to the VAV Zone II's outputs	28
Wiring specifications	28
Wiring diagram legend	29
No heat - Single duct or fan box application.....	29
2-position hot water/steam heat - Single duct.....	30
Modulating hot water/steam (ducted or baseboard) - Single duct application.....	31
Combination heat (ducted electric heat with modulating baseboard heat) - Single duct application	32
Electric heat (ducted or baseboard) - Single duct application.....	33
SCR electric heat (ducted or baseboard) - Single duct application.....	34
2-position hot water/steam (ducted or baseboard) - Fan box application	35
Modulating hot water (ducted or baseboard) - Fan box application	36
Combination heat (ducted electric heat with modulating baseboard heat) - Fan box application.....	37
2-stage electric heat (ducted or baseboard) - Fan box application.....	38
SCR electric heat (ducted or baseboard) - Single duct application.....	39
Wiring a field-supplied high-torque actuator to the analog output.....	40
Start-up.....	41
Configuring the VAV Zone II's properties.....	41
Configuring ZS Sensors.....	42
Performing system checkout.....	42
Commissioning the VAV Zone II	43
Balancing the system using the i-Vu®/Field Assistant applications.....	44
Prepare for balancing.....	44
Balance each zone	45

Balancing the system using Test & Balance tool	45
To calibrate VAV Zone airflow	46
Upload calibration values to the i-Vu® application	47
Run a report in VAV Zone II (Optional).....	47
Balancing the system	48
Prepare for balancing.....	48
Sequence of operation	49
Temperature sensors	49
Zone airflow control.....	50
Zone reheat control	51
Demand control ventilation (DCV) and dehumidification using optional sensors.....	52
Occupancy.....	53
Alarms	54
Demand limiting	55
Linkage.....	56
Linkage modes and determination	58
To adjust the driver properties	60
Driver	60
Device	61
Notification Classes.....	62
Calendars	63
Common Alarms.....	63
Specific Events	64
Switches, Jumpers, Options	64
Flow Calibration Archive	64
Act Net Network Details	65
Troubleshooting	66
LED's	66
To get the serial number	67
To restore factory defaults	67
To replace the battery	68
To clean the airflow sensor orifice	68
Compliance	70
FCC Compliance	70
CE Compliance	70
BACnet Compliance.....	70
Appendix A: VAV Zone II Points/Properties	71
Status.....	71
Unit Configuration.....	72
Setpoints	74
Alarm Configuration	81
Service Configuration	83
Maintenance.....	90
Alarms	93
Linkage.....	94
I/O Points.....	96
Appendix B: VAV terminal modes	99
Appendix C: ZS Sensor display for VAV Zone II	101
Appendix D: BACnet points list for the VAV Zone II Fan Terminal	102
Document revision history	105

Introduction

What are VAV Zone II controllers?

An i-Vu® Control System offers two VAV Zone II controllers, the VAV Zone II Single Duct (#OPN-VAVB1-02) and the VAV Zone II Fan Terminal (#OPN-VAVB3-02), to control zone temperature using single duct or fan-powered terminals in a Variable Air Volume (VAV®) application.

NOTE The single duct and fan terminal controllers are available in both English or Metric units. The metric version has (-M) appended to the part number. Everything in this document applies to both versions.

You can disconnect the actuator from the controller and mount them separately, connecting them with just the actuator cable or using an additional extension cable, up to a maximum distance of 300 feet.

Although a VAV Zone II can be included in a VVT system, this manual focuses mainly on its usage in VAV applications. The VAV Zone II has a detachable actuator and maintains zone temperature by operating the terminal fan and regulating the flow of conditioned air into the space. Buildings with diverse loading conditions can be supported by controlling the local terminal's supplemental heat. The VAV Zone II provides dedicated control functions for single duct, parallel fan box terminals and series fan box terminals with modulating heat, up to 2 stages of ducted heat, or combination baseboard and ducted heat.

The following illustration shows the VAV Zone II in a typical i-Vu® Control System.

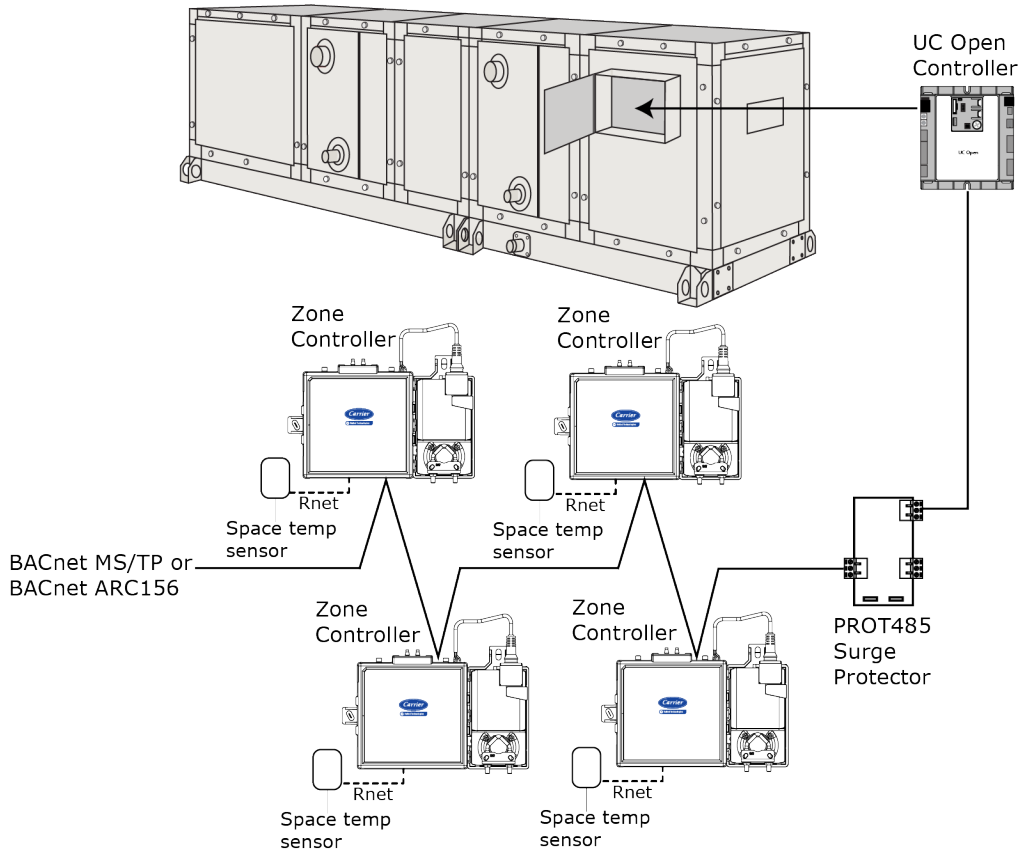

VAV Zone II Single Duct controller (#OPN-VAVB1-02)

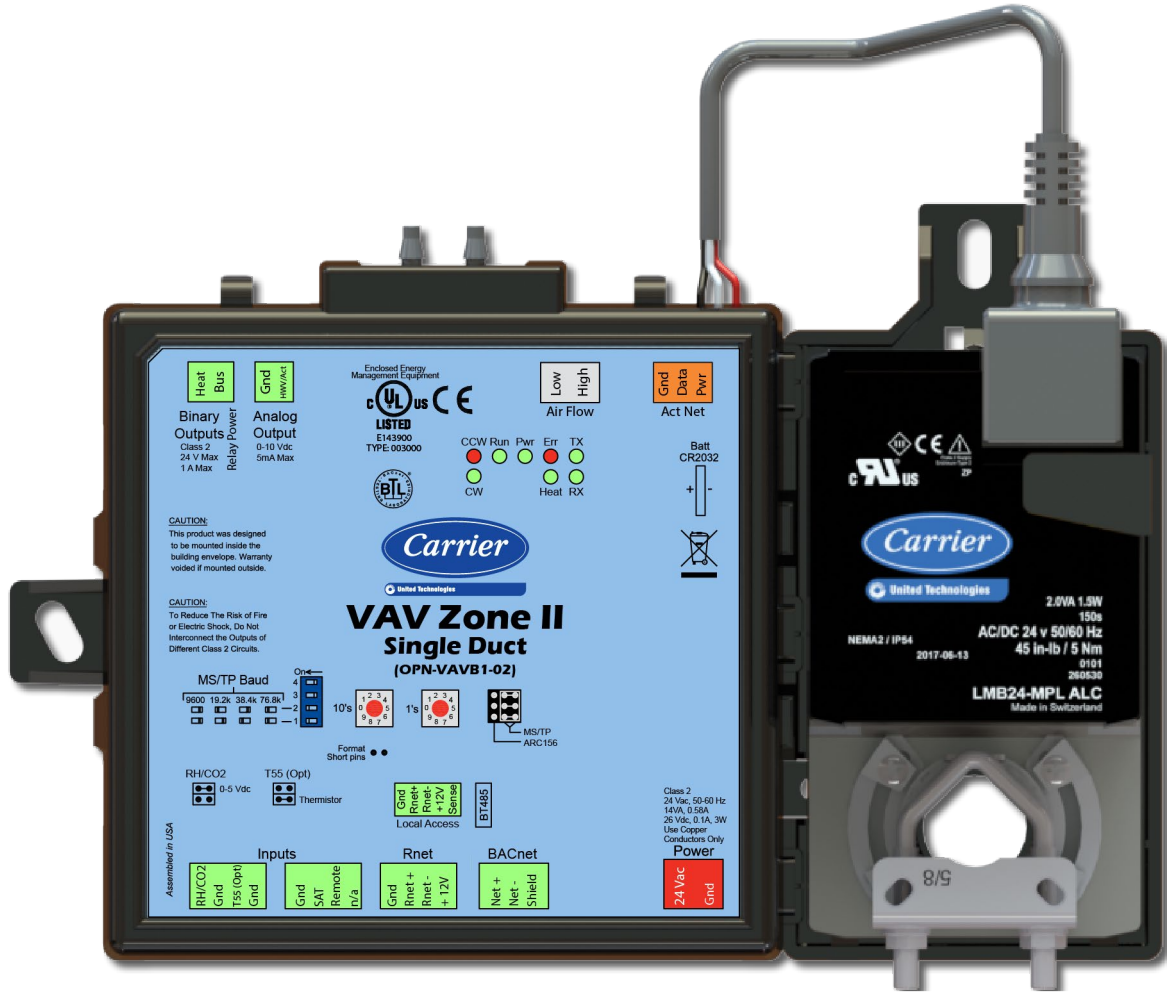

VAV Zone II Fan Terminal controller (#OPN-VAVB3-02)



NOTE This document gives instructions for field-installation of a VAV Zone II in an i-Vu® System. However, VAV Zone IIs are available factory-mounted to Carrier’s 35 single duct and 45 parallel and series fan terminals. All terminals require an integrated duct temperature sensor.

Specifications

Driver	<p>Part number</p> <p>OPN-VAVB1-02</p> <p>OPN-VAVB3-02</p>	<p>Driver</p> <p>drv_vav1opn02</p> <p>drv_vav3opn02</p>
Power	<p>24 Vac \pm10%, 50–60 Hz</p> <p>14 VA power consumption</p> <p>26 Vdc (25 V min, 28.8 V max)</p> <p>Single Class 2 source only, 100 VA or less</p>	
Actuator	Belimo brushless DC motor, torque 45 inch-pounds (5 Nm), runtime 154 seconds	
Act Net port	To connect the actuator cable and the VAV Zone II	
BACnet port	For communication with the controller network using BACnet ARC156 (156 kbps) or BACnet MS/TP (9600 bps – 76.8 kbps)	
Rnet port	<ul style="list-style-type: none"> Supports up to 5 wireless and/or ZS sensors, and one Equipment Touch or TruVu™ ET Display. Supplies 12 Vdc/200 mA power to the Rnet at an ambient temperature of 77 °F (25 °C) with a 24 Vac nominal power source. NOTE Ambient temperature and power source fluctuations may reduce the power supplied by the Rnet port. <p>NOTE If the total power required by the sensors on the Rnet exceeds the power supplied by the Rnet port, use an external power source. The Wireless Adapter, Equipment Touch, or TruVu™ ET Display must be powered by an external power source. See the specifications in each device's Installation and Start-up Guide to determine the power required.</p>	
Local Access port	For system start-up and troubleshooting	
Thermistor inputs	<p>Accepts Precon type II thermistors (10kOhm at 77 °F [25 °C])</p> <p>Range: -50 °F (-45.5 °C) to 250 °F (121.1 °C)</p>	
Dry contact inputs	A 3.3 Vdc wetting voltage used to detect the contact position, resulting in a 0.3 mA maximum sense current when the contacts are closed.	
Voltage inputs	0-5 Vdc. Input impedance is approximately 30 kOhms	
Input resolution	10 bit A/D	
Binary outputs	<p>#OPN-VAVB1-02: 1 binary output</p> <p>#OPN-VAVB3-02: 3 binary outputs</p> <ul style="list-style-type: none"> Relay contact rated at 1 A max. @ 24 Vac/Vdc. Configured normally open. 	
Analog output	1 analog output, 0–10 Vdc (5 mA max). The controlled device must have a minimum of 2000 Ohms resistance measured from its input to ground and must share the same ground as the controller.	
Output resolution	8 bit D/A	

Integral airflow sensor	Precision differential pressure sensor 0–2 in. H ₂ O, sensitive down to ±0.001 in. H ₂ O. Barbed tapered airflow connections accept 3/16 in. (4.75 mm) I.D. tubing. Allows for readings across the 0–2 in. H ₂ O range, accurate to ±5% of full flow at 2 in. H ₂ O.
Battery	10-year Lithium CR2032 battery retains the following data for a maximum of 10,000 hours during power outages: control programs, editable properties, schedules, and trends.
Protection	<p>Built-in surge and transient protection for power and communications in compliance with EN61000-6-1.</p> <p>Incoming power and network connections are protected by non-replaceable internal solid-state polyswitches that reset themselves when the condition that causes a fault returns to normal.</p> <p>The power, network, input, and output connections are also protected against transient excess voltage/surge events lasting no more than 10 msec.</p> <p> CAUTION To protect against large electrical surges on serial EIA-485 networks, place a PROT485 at each place wire enters or exits the building.</p>
BT485 connector	You attach a BT485 (not included) to a controller at the beginning and end of a network segment to add bias and to terminate a network segment.
Status indicators	LEDs indicate status of communications, running, errors, power, and digital outputs
Environmental operating range	32 to 130 °F (0 to 54.4 °C), 10–90% relative humidity, non-condensing
Storage temperature range	-24 to 140 °F (-30 to 60 °C), 0 to 90% relative humidity, non-condensing
Physical	UL94-5VA plenum rated enclosure for installation in plenum (or other space for environmental air) in accordance with NEC Section 300.22 (c) and (d)
Controller and actuator overall dimensions	Width: 8.9 in. (22.7 cm) Height: 5.9 in. (15.0 cm)
Controller and actuator mounting dimensions	7.1 in. (18.0 cm) from left side controller mounting hole centerline to actuator mounting hole centerline
Controller overall dimensions	Width: 6.4 in. (16.3 cm) Height: 5.7 in. (14.5 cm) Depth: 2.1 in. (5.3 cm)
Controller mounting dimensions	5.3 in. (13.4 cm) from left side controller mounting hole centerline to right side controller mounting hole centerline
Actuator overall dimensions	Width: 3.0 in. (7.6 cm) Height: 5.9 in. (15.0 cm) Depth: 2.5 in. (6.4 cm)
Actuator mounting dimensions	4.4 in. (11.2 cm) from shaft centerline to actuator mounting hole centerline
Panel depth	2.5 in. (6.4 cm) minimum
Shaft dimensions	Minimum shaft diameter: .25 in. (.64 cm) Maximum shaft diameter: .63 in. (1.59 cm) Minimum shaft length: 1.75 in. (4.45 cm)
Weight	1.8 lbs (0.82 kg)

BACnet support	Conforms to the BACnet Advanced Application Controller (B-AAC) Standard Device Profile as defined in ANSI/ASHRAE Standard 135-2012 (BACnet) Annex L, Protocol Revision 9
Listed by	UL-916 (PAZX), cUL-916 (PAZX7), FCC Part 15-Subpart B, Class B, CE

Linkage

The i-Vu® Control System uses linkage to exchange data between the zone terminals and their air source to form a coordinated HVAC system. The system's air source controller and zone controllers are linked so that their data exchange can be managed by one zone controller configured as the VAV Master.

A VAV Master can have a maximum of 63 slave zone controllers reporting to it. An MS/TP network is limited to a maximum of 60 controllers, but a VAV Master can have controllers from other networks as slaves.

A linked VAV system can be as simple as a single MS/TP network with a VAV Master and slaves, or it can be as complex as multiple MS/TP networks with VAV sub-masters and slaves on other networks. See the following examples.

EXAMPLE #1: A simple network. The VAV Master exchanges data between the slave controllers and the AHU controller. The linked controllers on an MS/TP network must be sequentially addressed, and the VAV Master must have the highest address.

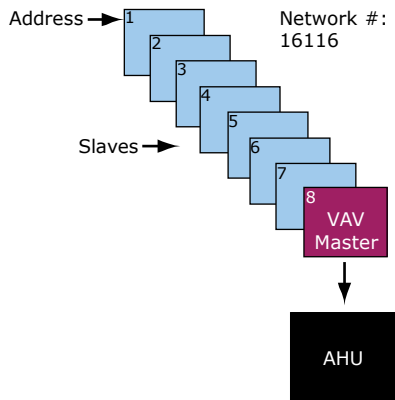

EXAMPLE #2: The above network plus slave controllers on other networks.

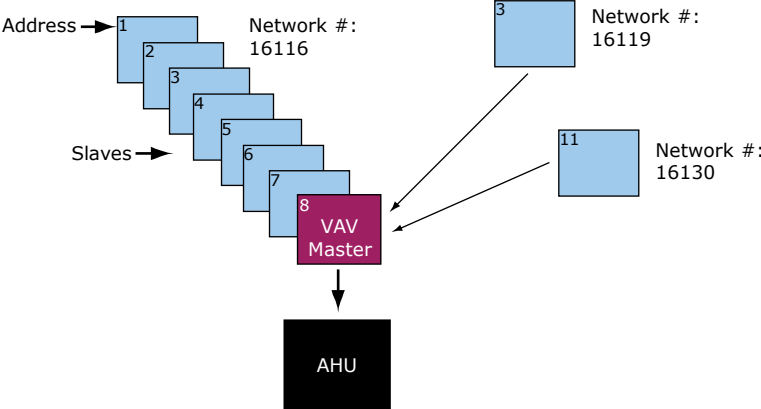

EXAMPLE #3: The above network plus sub-masters and their slaves. (For VAV systems only. VVT systems do not support sub-masters.) The sub-masters exchange data between their slaves and the VAV Master, and the VAV Master handles data exchange for the whole system.

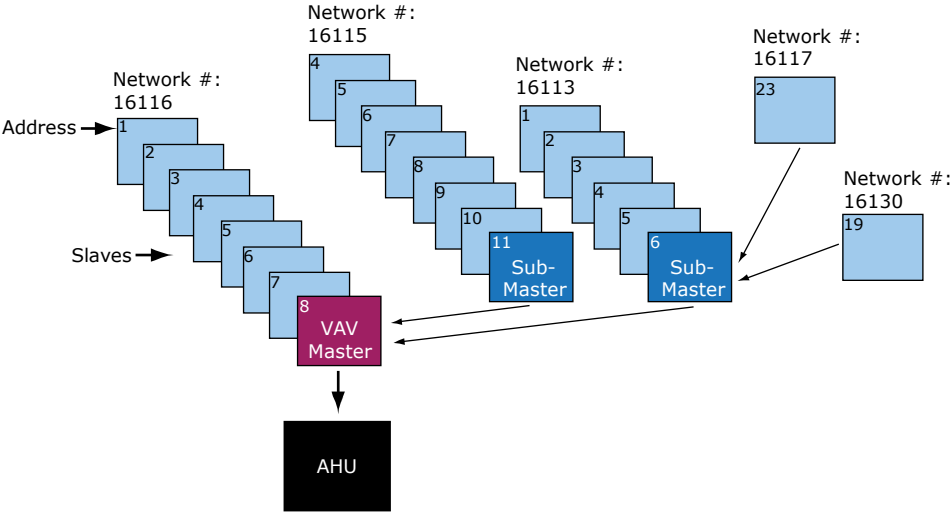

You set up linkage for the system by defining the Linkage properties for each controller. See *Linkage Properties* (page 94).

Safety Considerations



Air conditioning equipment will provide safe and reliable service when operated within design specifications. The equipment should be operated and serviced only by authorized personnel who have a thorough knowledge of system operation, safety devices, and emergency procedures.

Good judgment should be used in applying any manufacturer's instructions to avoid injury to personnel or damage to equipment and property.



Failure to follow this warning could cause personal injury, death, and/or equipment damage.

Disconnect all power to the unit before performing maintenance or service. Unit may automatically start if power is not disconnected.

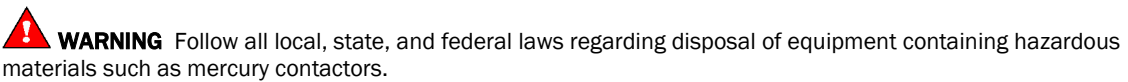

Field-supplied hardware

Each zone controller installation requires the following field-supplied components:

- zone terminal unit
- round or rectangular mounting bracket
- space temperature sensor
- supply air temperature sensor
- 2x4 in. standard single gang electrical box
- transformer – 24 Vac, 40 VA
- two no. 10 x 1/2-in. sheet metal screws (to secure SAT sensor to duct)
- two no. 6-32 x 5/8-in. screws (to mount space temperature sensor base to electrical box)
- wiring
- bushings (required when mounting SAT sensor in a duct 6-in. (15.2 cm) or less in diameter)

Optional:

- contractors (if required for fan or electric heat)
- indoor air quality sensor
- relative humidity sensor
- 2 screws and 2 hollow wall anchors (to mount relative humidity sensor directly to wall)
- valve and actuator for hot water heat (if required)

Installing the VAV Zone II

- 1 *Mount the controller to the VAV terminal. (page 9)*
- 2 *Wire the controller for power. (page 14)*
- 3 *Set the controller's address. (page 15)*
- 4 *Connect the controller to the BACnet MS/TP or BACnet ARC156 network. (page 15)*
- 5 *Wire devices to the Rnet port (page 17).*
- 6 *Wire sensor(s) to the controller. (page 22)*
- 7 *Wire equipment to the controller's outputs. (page 28)*

Mounting the VAV Zone II

To mount the controller and actuator

To disconnect and mount the controller and actuator separately

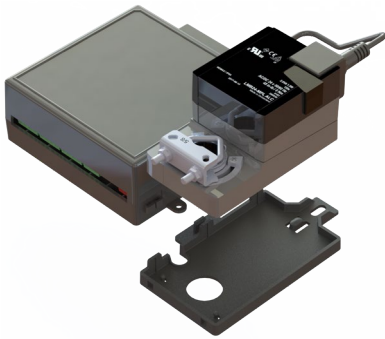

Disconnect the actuator from the controller by inserting a screw driver in the slot on the back of the VAV Zone II and pressing the tab. The actuator cable or an attached extension cable must connect to the controller's **Act Net** port.

Installing the VAV Zone II

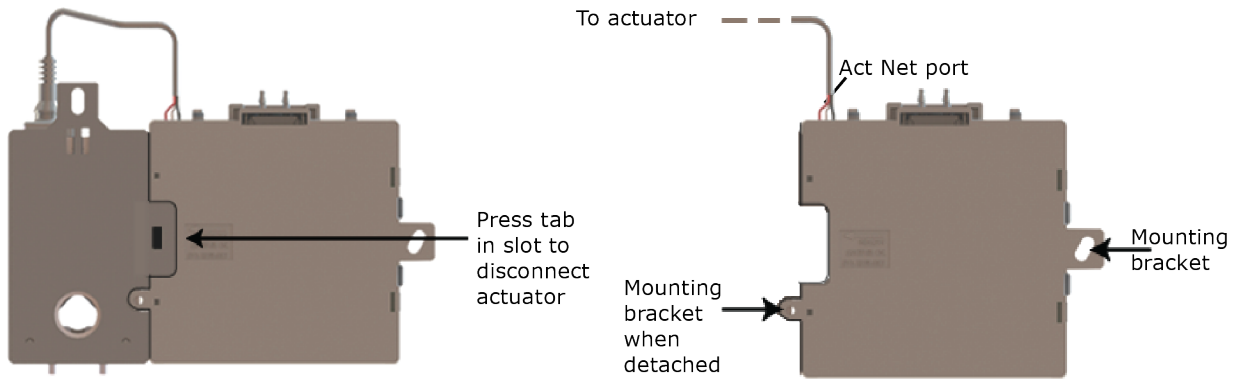

Adding an extension cable

If you need to mount the actuator more than 14 in. from the controller, you can use an 18 AWG wire for an extension cable. The maximum distance that the actuator and controller can be separated is 300 feet (91.4 m). Connect the extension cable to the end of the actuator cable. You can use connectors or splice the wires. Terminate the extension cable in the **Act Net** port on the controller.

To mount the VAV Zone II

- 1 Turn the damper shaft to fully close the damper.
- 2 Mount the controller to the VAV terminal by sliding the clamp assembly onto the damper shaft.

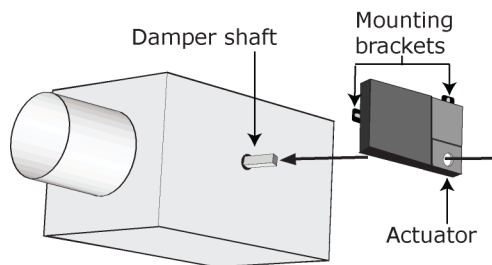

NOTE For service access, allow at least 1 foot (.3 m) of clearance between the front of the controller and adjacent surfaces.

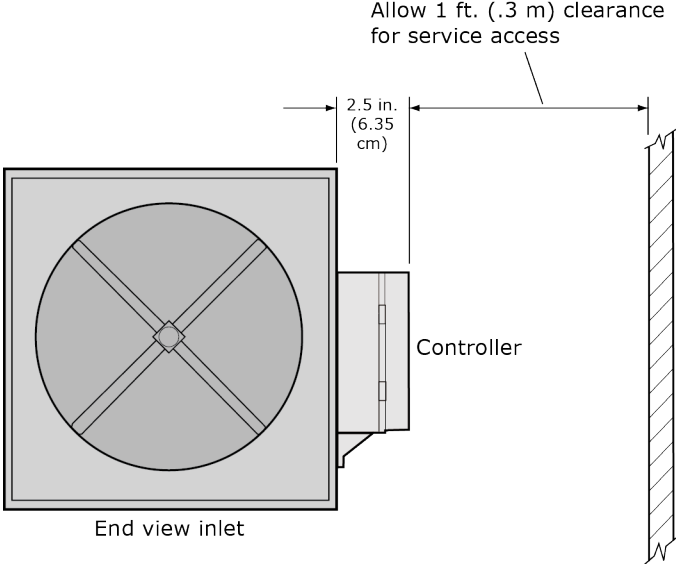

3 Secure the controller and the actuator by installing the screws, anti-rotation slot's bushings, and o-rings that are supplied with the VAV Zone II.

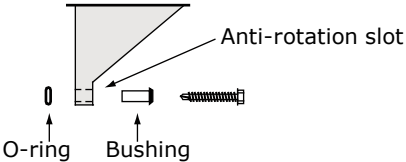

NOTES

- Center the bushing in the slot. Failure to do so may cause the actuator to stick or bind.
- The VAV Zone II must be secured, but loose enough to allow movement. of the damper shaft.

 **CAUTIONS**

- You **must** use the screws, anti-rotation slot's bushings, and o-rings that are shipped with the VAV Zone II.
- Overtightening the screws so that the controller and actuator cannot move may damage the unit.

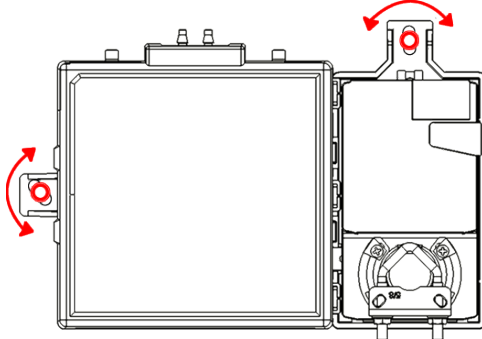

- 4** Hold down the VAV Zone II's actuator release button and rotate the actuator clamp in the same direction that closed the damper. Rotate the clamp until it stops, then rotate it back one notch.

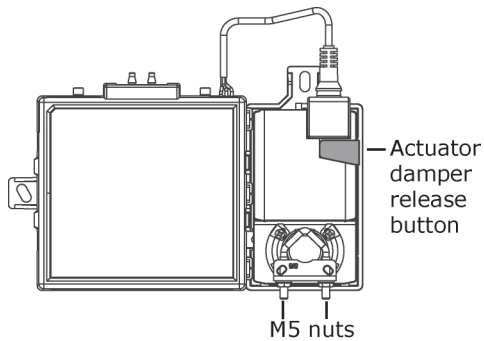

- 5** Release the button.
- 6** Tighten the actuator clamp to the damper shaft by tightening the two M5 nuts.
- 7** Hold down the actuator damper release button and rotate the damper from fully closed to fully open. If the damper traveled less than 90 degrees, do the following to set the actuator's fully open position:
- a) Loosen the appropriate stop clamp screw. See figure below.
 - b) Move the stop clamp until it contacts the edge of the actuator cam.
 - c) Tighten the screw.

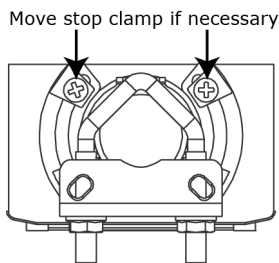

- 8 Hold down the actuator damper release button, rotate the damper to verify that it fully opens and closes, then release the button.

To connect duct tubes to the flow sensors

The VAV Zone II controls airflow using the actuator and flow sensor.

- 1 Turn off the VAV Zone II's power.
- 2 Connect the tubes to the VAV Zone II's **High** and **Low** connectors.
- 3 **NOTE** Tubing should be at least 2 ft. (.61 meters) long for stable airflow measurement. The combined high and low tubing length should not exceed 16.4 ft. (5 meters) in order to ensure accurate measurements.
- 4 Connect the other ends of the poly tubing to the airflow pickup located in the terminal's primary air inlet. Avoid sharp bends in the tubing.
- 5 Connect **High to High** and **Low to Low**.

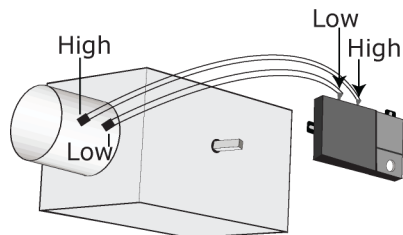
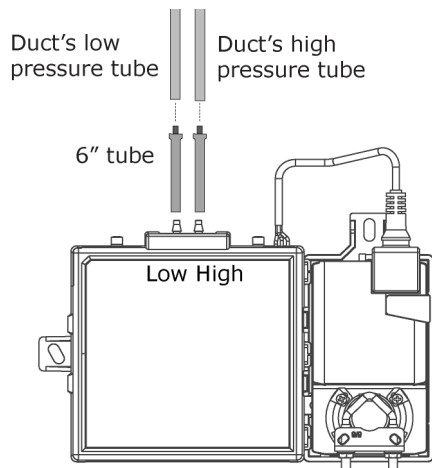

Wiring the VAV Zone II for power

 **WARNING** Do not apply line voltage (mains voltage) to the controller's ports and terminals.

 **CAUTIONS**

- The VAV Zone II is powered by a Class 2 power source. Take appropriate isolation measures when mounting it in a control panel where non-Class 2 circuits are present.
- Carrier controllers can share a power supply as long as you:
 - Maintain the same polarity.
 - Use the power supply only for Carrier controllers.

To wire the controller for power

- 1 To access the screw terminal connectors, lift up the controller's cover by pulling the tabs located on both sides of the controller's left mounting bracket.

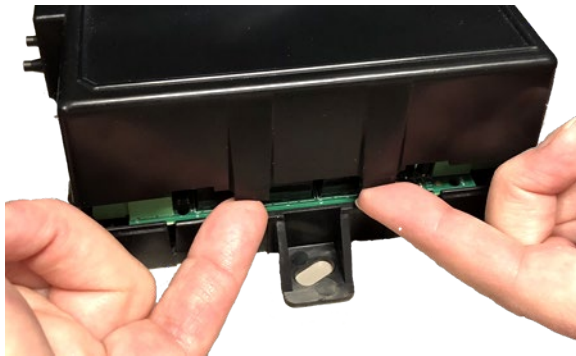

- 2 Remove power from the power supply.
- 3 Pull the screw terminal connector from the controller's power terminals labeled **Gnd** and **24 Vac**.

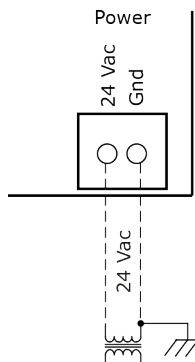

- 4 Connect the transformer wires to the screw terminal connector.

- 5 Apply power to the power supply.
- 6 Measure the voltage at the VAV Zone II's power input terminals to verify that the voltage is within the operating range of 21.6–26.4 Vac.
- 7 Connect a 4-inch (10.2 cm) wire from **Gnd** to the control panel.
- 8 Insert the screw terminal connector into the VAV Zone II's power terminals.
- 9 Verify that the **Power** LED is on and the **Run** LED is blinking.

Addressing the VAV Zone II

You must give the VAV Zone II an address that is unique on the network. You can address the VAV Zone II before or after you wire it for power.

- 1 If the VAV Zone II has been wired for power, pull the screw terminal connector from the controller's power terminals labeled **Gnd** and **24 Vac**. The controller reads the address each time you apply power to it.
- 2 Using the rotary switches, set the controller's address. Set the **Tens (10's)** switch to the tens digit of the address, and set the **Ones (1's)** switch to the ones digit.

EXAMPLE If the controller's address is 25, point the arrow on the **Tens (10's)** switch to 2 and the arrow on the **Ones (1's)** switch to 5.

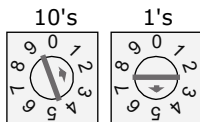

 **CAUTION** The factory default setting is **00** and must be changed to successfully install your VAV Zone II.

Wiring for communications

The VAV Zone II communicates using BACnet on the following types of network segments:

- MS/TP communicating at 9600 bps, 19.2 kbps, 38.4 kbps, or 76.8 kbps
- ARC156 communicating at 156 kbps

NOTE For more networking details, see the *Open Controller Network Wiring Installation Guide*.

Wiring specifications for BACnet MS/TP and ARC156

Cable:	22 AWG or 24 AWG, low-capacitance, twisted, stranded, shielded copper wire
Maximum length:	2000 feet (610 meters)

 **WARNING** Do not apply line voltage (mains voltage) to the controller's ports and terminals.

To wire the controller to the BACnet network

 **WARNING** Attaching any ARCNET or MS/TP network to the **Act Net** port damages BT485s, DIAG485s, or terminating resistors on that network.

- 1 Pull the screw terminal connector from the controller's power terminals labeled **Gnd** and **24 Vac**.
- 2 Check the communications wiring for shorts and grounds.
- 3 Connect the communications wiring to the controller's screw terminals labeled **Net +**, **Net -**, and **Shield**.

NOTE Use the same polarity throughout the network segment.

- 4 Set the communication type and baud rate.

For...	Set BACnet ARC156 or MS/TP jumper to...	Set DIP switches 1 and 2 to...
ARC156	ARC156	N/A. Baud rate will be 156 kbps regardless of the DIP switch settings.
MS/TP	MS/TP	The appropriate baud rate. See the MS/TP Baud diagram on the controller.

NOTE Use the same baud rate for all controllers on the network segment.

- 5 If the VAV Zone II is at either end of a network segment, connect a BT485 to the VAV Zone II.
- 6 Insert the power screw terminal connector into the VAV Zone II's power terminals.
- 7 Verify communication with the network by viewing a Module Status report in the i-Vu® interface.

Wiring devices to the VAV Zone II's Rnet port

The Rnet communicates at a rate of 115 kbps and should be wired in a daisy-chain or hybrid configuration.

Supports up to

- 5 wireless and/or ZS sensors
- One Equipment Touch
- One TruVu™ ET Display

For more detailed instructions, see the device's *Installation Guide*.



CAUTION Rnet power

The Rnet port provides 12 Vdc/200 mA* maximum at 32°F (25°C). that can be used to power zone sensors. If the total power required by the sensors on the Rnet exceeds the power supplied by the port, use an external power supply. See the sensor's Installation and Start-up Guide to determine the power required.

* These numbers will be reduced at higher temperatures.

Wiring specifications

Cable from sensor to controller:	If <100 ft (30.5 meters)	22 AWG, unshielded
	If >100 ft (30.5 meters)	22 AWG, shielded
Maximum length:	500 feet (152 meters)	

To wire ZS sensors to the controller

ZS Sensors are thermistor-based temperature sensors that may optionally sense humidity, CO₂, or VOC. ZS Sensors are wired to the Rnet port on i-Vu® Open controllers.

You can use the following ZS sensors:

- ZS Standard
- ZS Plus
- ZS Pro

NOTE The ZS CO₂ model uses 190 mA during sample period. Use auxiliary 12 Vdc, unless it is the only device on the Rnet port.

- 1 Remove power from the VAV Zone II.

- Partially cut, then bend and pull off the outer jacket of the Rnet cable(s). Do not nick the inner insulation. Strip about .25 inch (.6 cm) of the inner insulation from each wire.

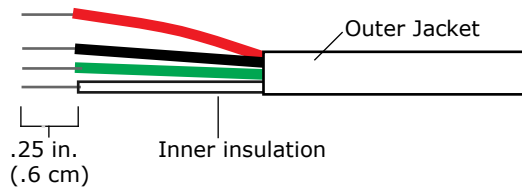

- Wire each terminal on the sensor to the same terminal on the controller. See diagram below.

NOTE Carrier recommends that you use the following Rnet wiring scheme:

Connect this wire...	To this terminal...
Red	+12V
Black	Rnet-
White	Rnet+
Green	Gnd

- Apply power to the VAV Zone II.

To wire the Wireless Adapter for wireless sensors

WARNING Do not apply line voltage (mains voltage) to the Wireless Adapter.

The Carrier wireless sensors are available in 868, 902, and 928 MHz radio frequency. The sensors are thermistor-based temperature sensors that may optionally sense humidity.

Wireless sensors communicate through a Wireless Adapter, which is wired to the Rnet port of the controller.

REQUIREMENTS

- A v6.5 or later i-Vu® system
- v6-xx-xxx or later controller drivers

To configure the control program for the desired user interaction with the sensor, see the *Wireless Sensors Application Guide*. For detailed instructions, see the *Wireless Sensors Installation Guide*.

To wire, power, and mount the Wireless Adapter

NOTES

- The Wireless Adapter requires a 24 Vac power supply. It is not powered by the Rnet.
- If the Wireless Adapter will be:
 - Daisy-chained on the Rnet with ZS sensors, an Equipment Touch, or TruVu™ ET Display use the standard 4-conductor Rnet wiring.
 - The only device on the Rnet, you can use a 3-conductor cable instead of the standard 4-conductor Rnet cable.

- 1 Turn off the power to the controller that the Wireless Adapter will be wired to.
- 2 Partially cut, then bend and pull off the outer jacket of the Rnet cable(s). Do not nick the inner insulation.

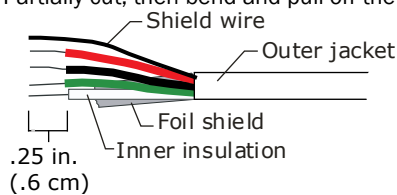

- 3 Strip about 0.25 inch (0.6 cm) of the inner insulation from each wire.
- 4 Wire the **Rnet +**, **Rnet -**, and **Gnd** terminals on the controller's **Rnet** port to the terminals of the same name on the Wireless Adapter's Rnet connector.

NOTE If using shielded wire, connect the shield wire and the ground wire to the **Gnd** terminal.

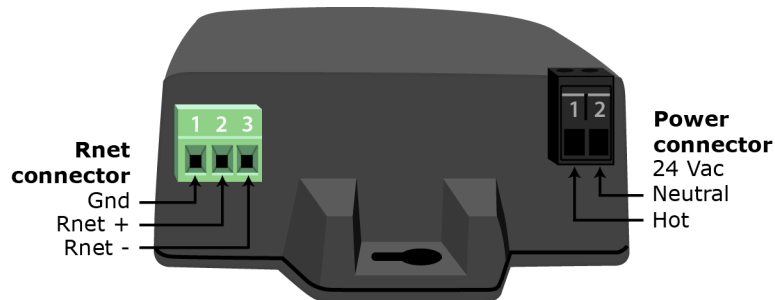

- 5 Wire the 24 Vac external power supply to the Wireless Adapter's power connector.
- 6 Mount the Wireless Adapter by inserting 2 screws through the mounting tabs on each end of the Wireless Adapter.
- 7 Apply power to the external power supply.
- 8 Verify that the LED on top of the Wireless Adapter is blinking. See "LED" below.
- 9 Turn on the controller's power.

LED

The blue LED on the top of the Wireless Adapter indicates the following:

If the LED is...	Then the device...
Off	Is not powered or there is a problem.
Blinking	Is working properly.
Steadily on	Has a problem. Do one of the following: <ul style="list-style-type: none"> • Cycle power to the device. • Insert a small screwdriver or paper clip into the hole next to the LED to reboot the device.

To wire an Equipment Touch to the VAV Zone II

NOTES

- The Equipment Touch requires a 24 Vac power supply. It is not powered by the Rnet.
- If the Equipment Touch will be:
 - Daisy-chained on the Rnet with ZS sensors or a Wireless Adapter, use the standard 4-conductor Rnet wiring and follow the wiring instructions *To wire ZS sensors to the VAV Zone II* (page 17).
 - The only device on the Rnet, you can use a 2-conductor cable instead of the standard 4-conductor Rnet cable and follow the instructions below.
- For complete Equipment Touch installation instructions including wiring diagrams, see the *Equipment Touch Installation and Setup Guide*.



CAUTION The VAV Zone II can share a power supply with the Carrier controller as long as:

- The power supply is AC power.
- You maintain the same polarity.
- You use the power source only for Carrier controllers.

- 1 Turn **off** the VAV Zone II's power.
- 2 Partially cut, then bend and pull off the outer jacket of the cable. Do not nick the inner insulation.

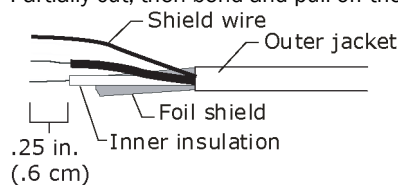

- 3 Strip about 0.25 inch (0.6 cm) of the inner insulation from each wire.
- 4 Wire the VAV Zone II's **Rnet+** and **Rnet-** terminals to the terminals of the same name on the Equipment Touch's connector.

NOTE If using shielded wire, connect the shield wire and the ground wire to the **Gnd** terminal.

- 5 Turn **on** the VAV Zone II's power.
- 6 Turn on the Equipment Touch.

To wire the TruVu™ ET Display

 **WARNING** Do not apply line voltage (main) - 24 Vdc power only.

Wiring power

Wire the TruVu™ ET Display **24V DC** connector to the 24 Vdc power supply using 2-conductor 18 AWG wire. Maximum distance 100 feet (30 meters).

 **CAUTION** The TruVu™ ET Display can share a power supply with the Carrier controller as long as:

- The power supply is DC power.
- You maintain the same polarity.
- You use the power source only for Carrier controllers.

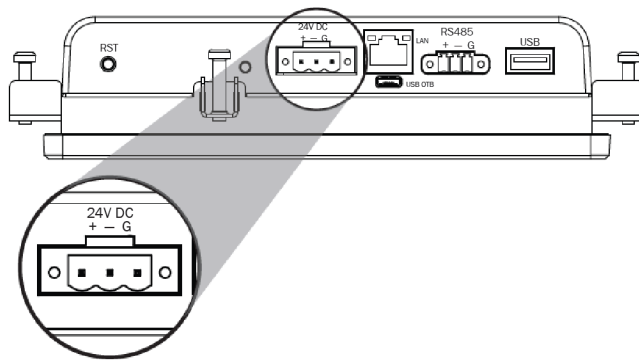

Wiring communication

- 1 Turn off the VAV Zone II's power.
- 2 Wire the TruVu™ ET Display's **RS485** connector to the <ALCProduct>'s **Rnet** port, **Gnd** to **Gnd**, **+** to **Rnet +**, **-** to **Rnet -** using 2-conductor 22 AWG wire with a maximum distance of 500 feet (152 meters).

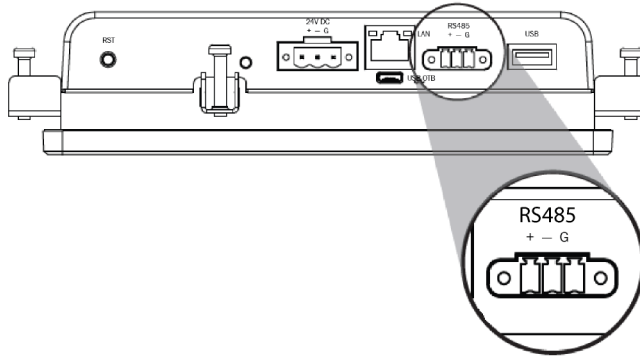

- 3 Turn on the VAV Zone II's power.

For complete TruVu™ ET Display installation instructions, see the *TruVu™ ET Display Installation and Start-up Guide*.

Wiring sensors to the VAV Zone II's inputs

You can wire the following sensors to the controller:

- *Alternate space temperature sensor* (page 23)
- *Supply Air Temperature sensor* (page 24)
- *CO₂ sensor* (page 24)
- *Relative Humidity sensor* (page 26)
- *Remote occupancy contact sensor* (page 27)

NOTE This document gives instructions for wiring the sensors to the VAV Zone II. For mounting and wiring the sensors, see the *Carrier Sensors Installation Guide*.

WARNING  Disconnect electrical power to the VAV Zone II before wiring it. Failure to follow this warning could cause electrical shock, personal injury, or damage to the controller.

CAUTION

- Do not run sensor or relay wires in the same conduit or raceway with Class 1 AC or DC service wiring.
- Do not abrade, cut, or nick the outer jacket of the cable.
- Do not pull or draw cable with a force that may harm the physical or electrical properties.
- Avoid splices in any control wiring.

To wire the T55 sensor to the controller

Part #33ZCT55SPT

This wall-mounted sensor monitors space temperature and can be used instead of a ZS or wireless sensors.

- 1 Strip the outer jacket from the cable for at least 3 inches (7.62 cm). Strip .25 inch (.6 cm) of insulation from each wire. Cut the shield and drain wire from the cable.
- 2 Wire the sensor to the controller, attaching the red wire to the **T55 (Opt)** terminal and the black wire to the **Gnd** terminal. See diagram below.
- 3 Verify that the **T55 (Opt)** jumper is in the **Thermistor** position.

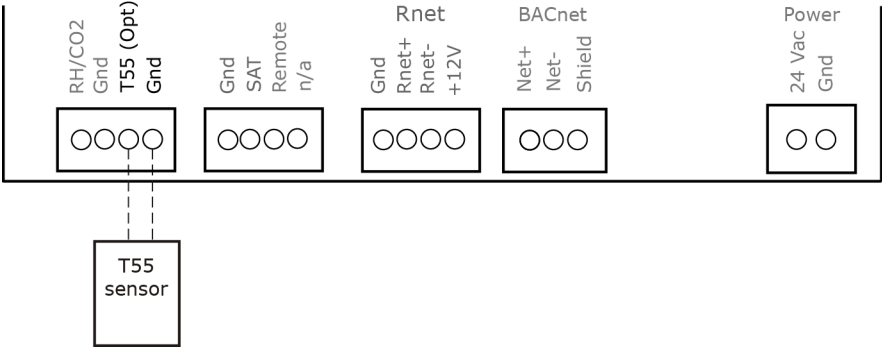

To wire the Supply Air Temperature sensor to the controller

Part #33ZCSENSAT

Each VAV Zone II requires that a temperature sensor be installed in the supply air stream. Mount the SAT sensor at least 2 feet downstream from a hot water or steam coil, or at least 4 feet downstream from an electric heating coil.

Wire the sensor to the controller. See diagram below.

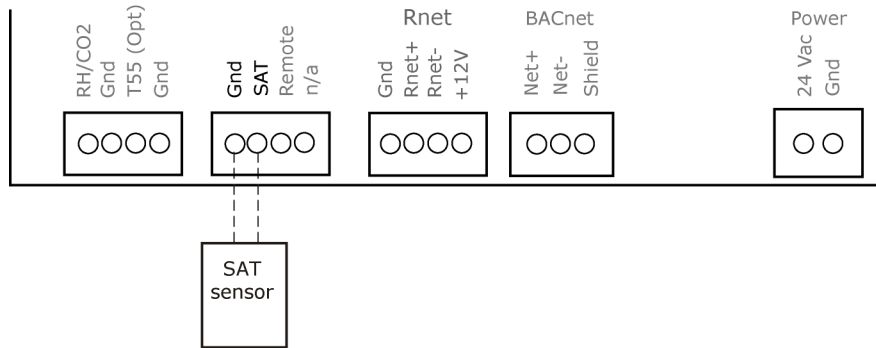

To wire the CO2 sensor to the controller

Part #33ZCSPTCO2LCD-01 (Display model)
 Part #33ZCSPTCO2-01 (No display)
 Part #33ZCT55CO2 (No display)

A CO₂ sensor monitors carbon dioxide levels. As CO₂ levels increase, the VAV Zone II adjusts the outside air dampers to increase ventilation and improve indoor air quality. These sensors also monitor temperature using a 10K thermistor.

A CO₂ sensor can be wall-mounted or mounted in a return air duct. (Duct installation requires an Aspirator Box Accessory - Part #33ZCASPCO2.)

The sensor has a range of 0–2000 ppm and a linear 4-20 mA output. This is converted to 1-5 Vdc by a 250 Ohm, 1/4 watt, 2% tolerance resistor connected across the zone controller's CO₂ input terminals.

NOTE Do not use a relative humidity sensor and CO₂ sensor on the same zone controller.

#33ZCSPTCO2

- 1 Wire the sensor to the controller. See appropriate diagram below.
- 2 Verify that the **RH/CO2** jumper is set to **0-5 Vdc** on the VAV Zone II.
- 3 Verify the **J7** jumper on the sensor is set to **0-5 Vdc**.

Wiring diagram for #33ZCSPTCO2:

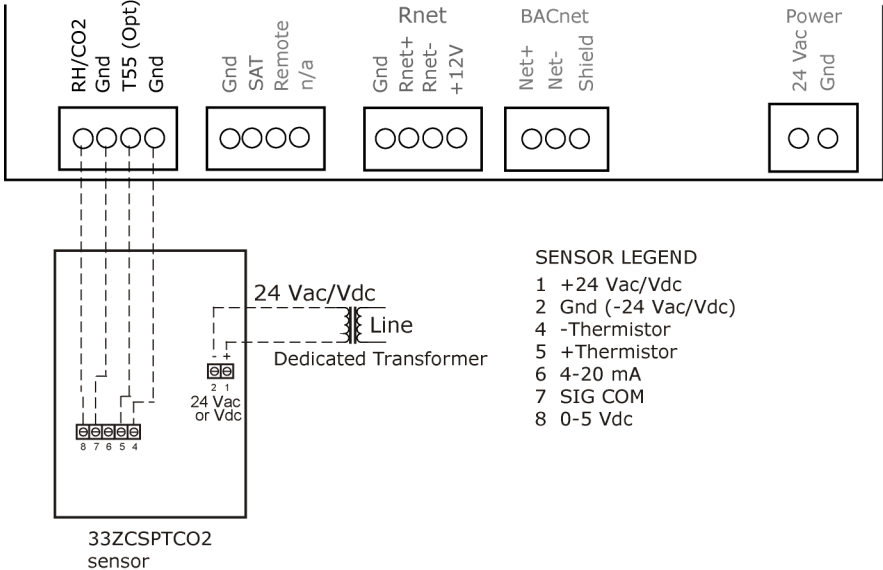

#33ZCT55C02

- 1 Wire the sensor to the controller. See appropriate diagram below.
- 2 Install a field supplied 250 Ohm 1/4 watt 2% tolerance resistor across the controller's **RH/CO2** and **Gnd** terminals.
- 3 Verify that the **RH/CO2** jumper is set to **0-5Vdc** on the VAV Zone II.

Wiring diagram for #33ZCT55C02:

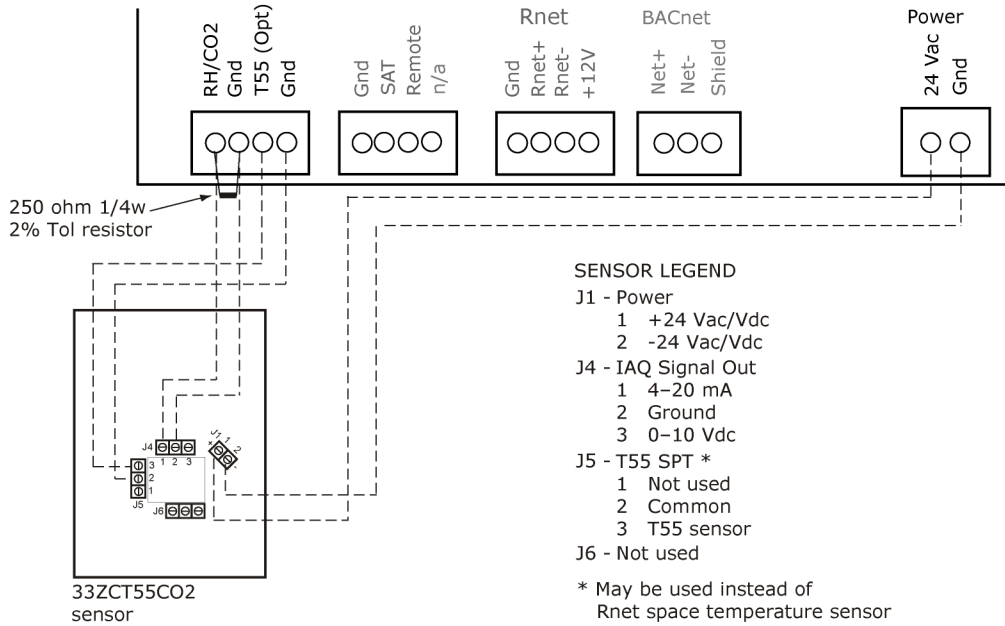

To wire the Relative Humidity sensor to the controller

Part #33ZCSENSRH-02

The Relative Humidity (RH) sensor is used for zone humidity control (dehumidification) if the rooftop unit has a dehumidification device. If not, the sensor only monitors humidity.

NOTE Do not use a relative humidity sensor and CO₂ sensor on the same zone controller.

- 1 Strip the outer jacket from the cable for at least 4 inches (10.2 cm). Strip .25 inch (.6 cm) of insulation from each wire.
- 2 Wire the sensor to the controller. See diagram below.
- 3 Using electrical tape, insulate any exposed resistor lead to prevent shorting.
- 4 Verify that the **RH/CO2** jumper is set to **0-5 Vdc**.

5 Set **SW3** on the sensor as shown below.

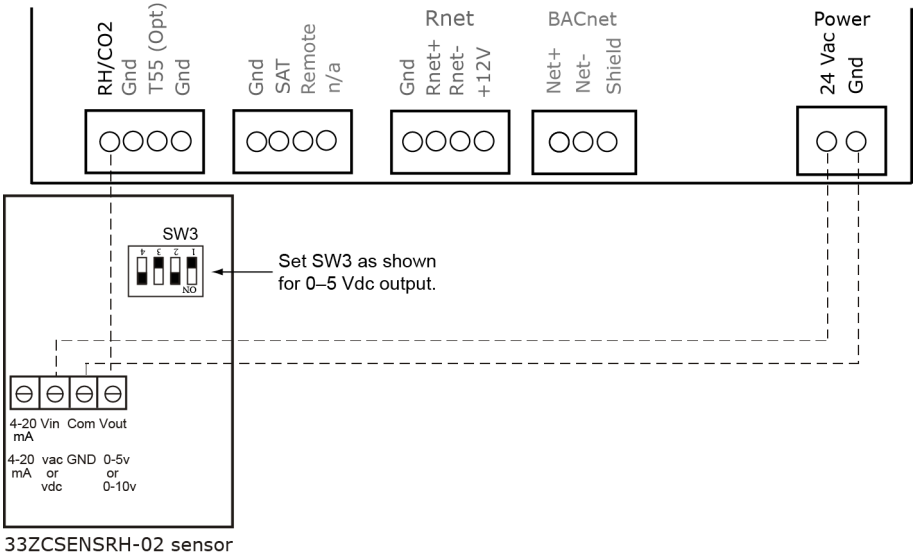

Wiring a remote occupancy sensor

You can wire a normally open or normally closed dry-contact occupancy sensor to the VAV Zone II's **REMOTE** input as shown below. The controller supplies the voltage needed for the input.

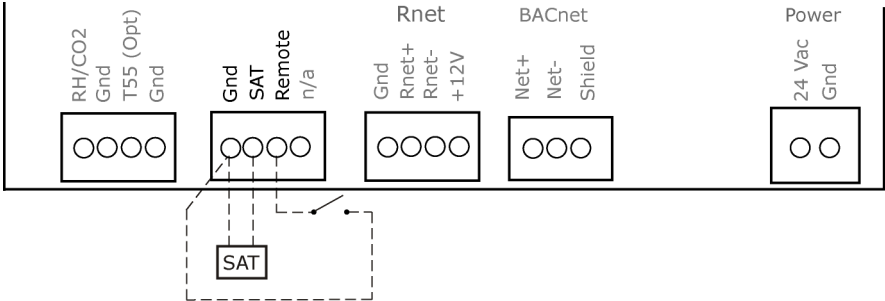

Wiring equipment to the VAV Zone II's outputs

Use the following wiring diagrams to wire zone terminal equipment to the VAV Zone II's outputs.

VAV Zone II Single Duct Controller or VAV Zone II Fan Terminal Controller

No heat - Single duct (page 29)

2-position hot water/steam heat - Single duct (ducted or baseboard) (page 30)

Modulating hot water/steam - Single duct (ducted or baseboard) (includes CV Modulating) (page 31)

Combination heat - Single duct (ducted electric heat with modulating baseboard heat) (page 32)

3-stage electric heat - Single duct (ducted or baseboard) (page 33)

SCR electric heat - Single duct (ducted or baseboard) (page 34)

VAV Zone II Fan Terminal Controller only

2-position hot water/steam - Fan box (ducted or baseboard) (page 35)

Modulating hot water/steam - Fan box (ducted or baseboard) (includes CV Modulating) (page 36)

Combination heat - Fan box (ducted electric heat with modulating baseboard heat) (page 37)

2-stage electric heat - Fan box (ducted or baseboard) (page 38)

SCR electric heat - Fan box (ducted or baseboard) (page 39)

Wiring a field-supplied high-torque actuator to the analog output (page 40)

 **WARNING** Disconnect electrical power to the VAV Zone II before wiring it. Failure to follow this warning could cause electrical shock, personal injury, or damage to the controller.

Wiring specifications

To size output wiring, consider the following:

- Total loop distance from the power supply to the controller, and then to the controlled device
NOTE Include the total distance of actual wire. For 2-conductor wires, this is twice the cable length.
- Acceptable voltage drop in the wire from the controller to the controlled device
- Resistance (Ohms) of the chosen wire gauge
- Maximum current (Amps) the controlled device requires to operate

Wiring diagram legend

- Gnd** = Ground
- HWV** = Hot water valve
- SAT** = Supply air temperature sensor
- SCR** = Silicon controlled rectifier
- Space temp sensor** = ZS sensors or Wireless Adapter for wireless sensors
- T55 (OPT)** = Alternate space temperature sensor
- - - = Field-supplied wiring

No heat - Single duct or fan box application

VAV Zone II Single Duct controller or **VAV Zone II Fan Terminal controller**

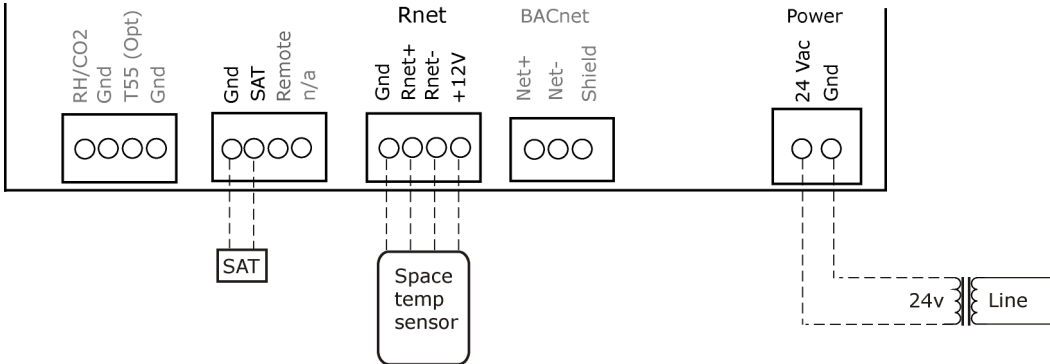

2-position hot water/steam heat - Single duct

VAV Zone II Single Duct controller or VAV Zone II Fan Terminal controller

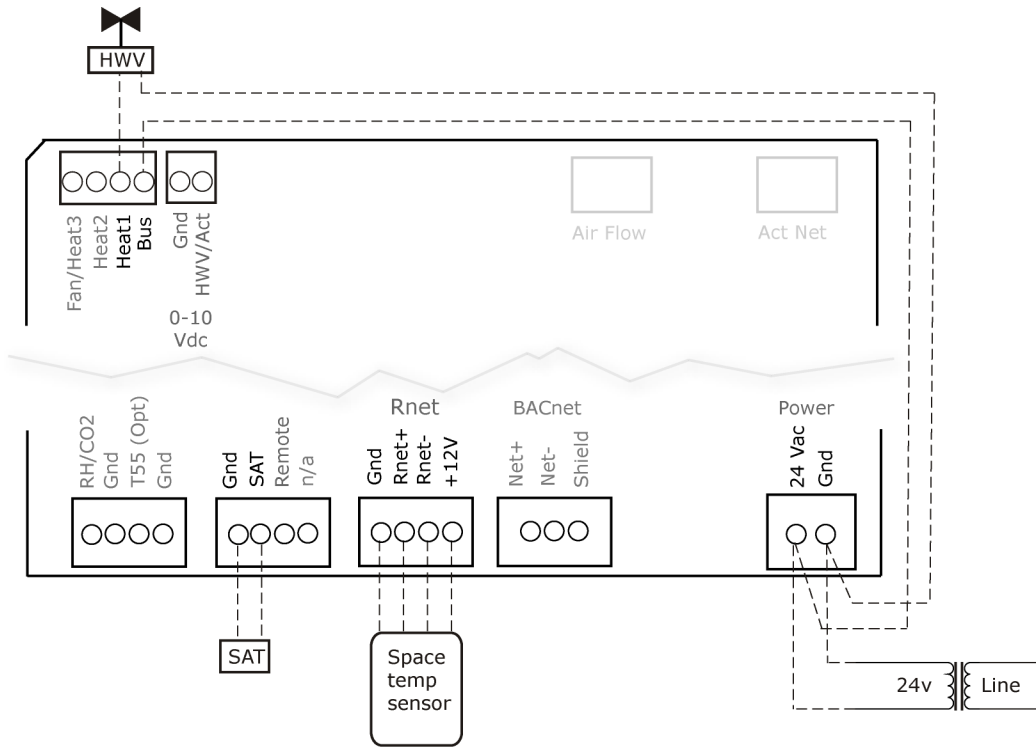

Modulating hot water/steam (ducted or baseboard) - Single duct application

VAV Zone II Single Duct controller or VAV Zone II Fan Terminal controller

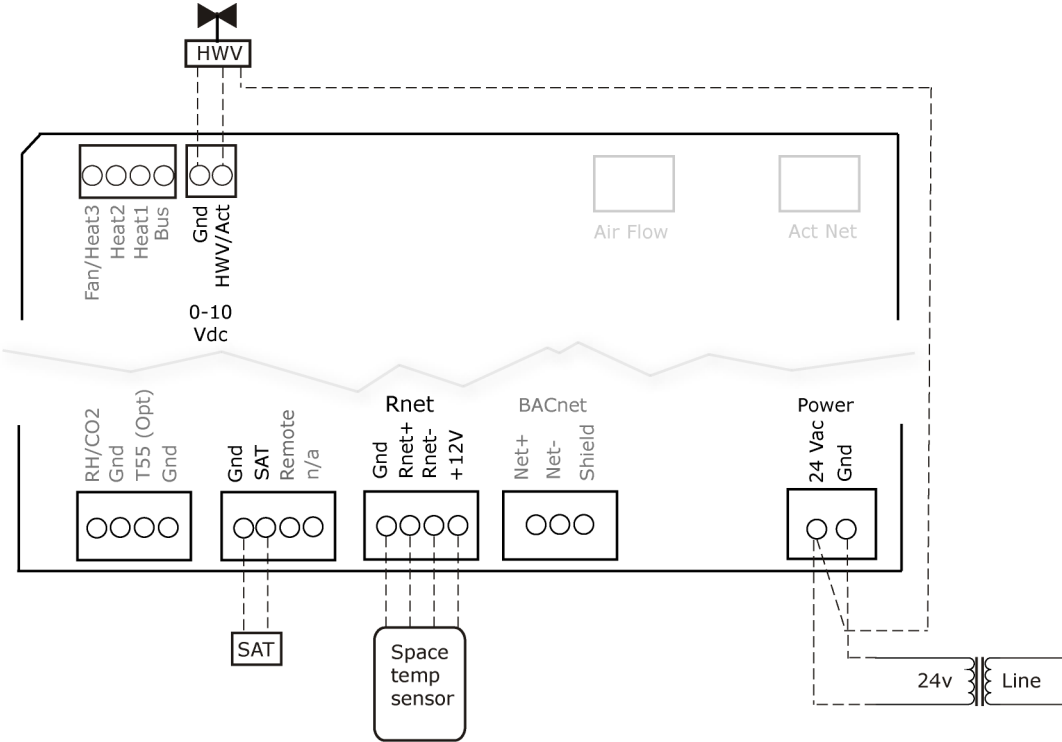

Combination heat (ducted electric heat with modulating baseboard heat) - Single duct application

VAV Zone II Single Duct controller or **VAV Zone II Fan Terminal controller**

NOTE Duct Heat 2 and Duct Heat 3 are available only with a VAV Zone II Fan Terminal Controller.

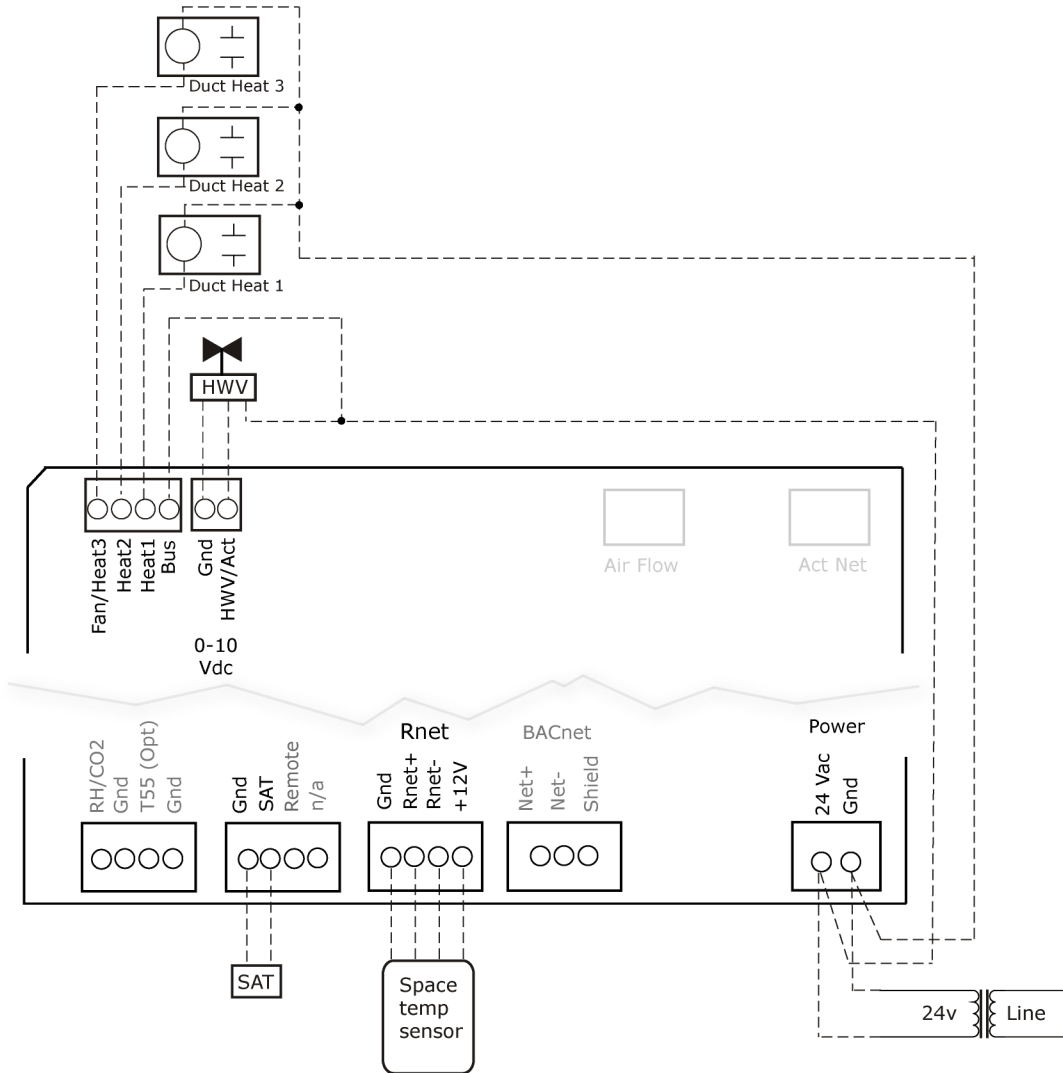

Electric heat (ducted or baseboard) - Single duct application

VAV Zone II Single Duct controller or VAV Zone II Fan Terminal controller

NOTE Stage Heat 2 and Stage Heat 3 are available only with a VAV Zone II Fan Terminal Controller.

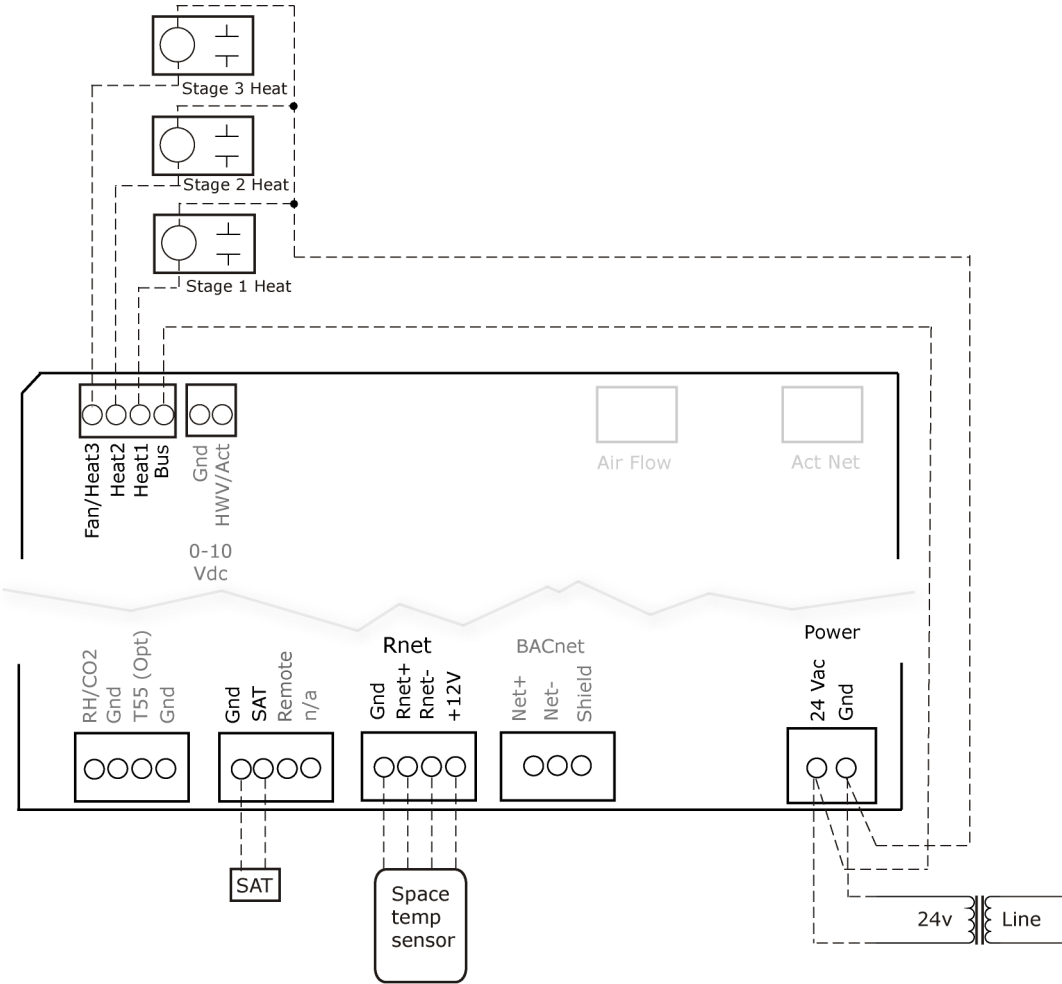

SCR electric heat (ducted or baseboard) - Single duct application

VAV Zone II Single Duct controller or VAV Zone II Fan Terminal controller

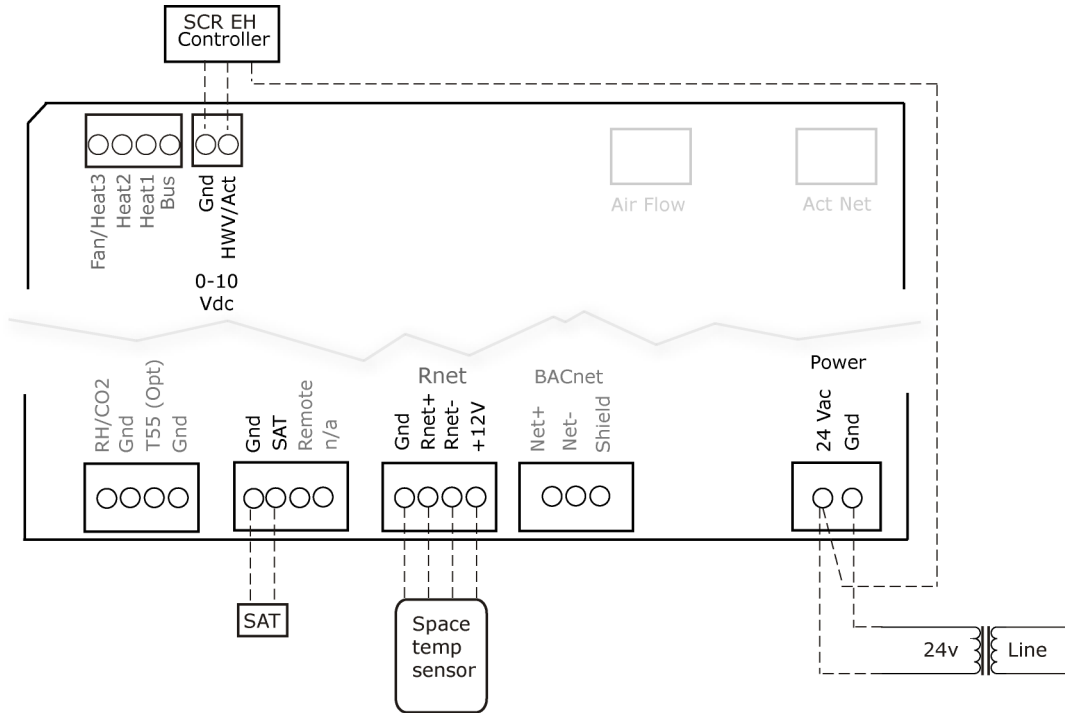

2-position hot water/steam (ducted or baseboard) - Fan box application

VAV Zone II Fan Terminal controller only

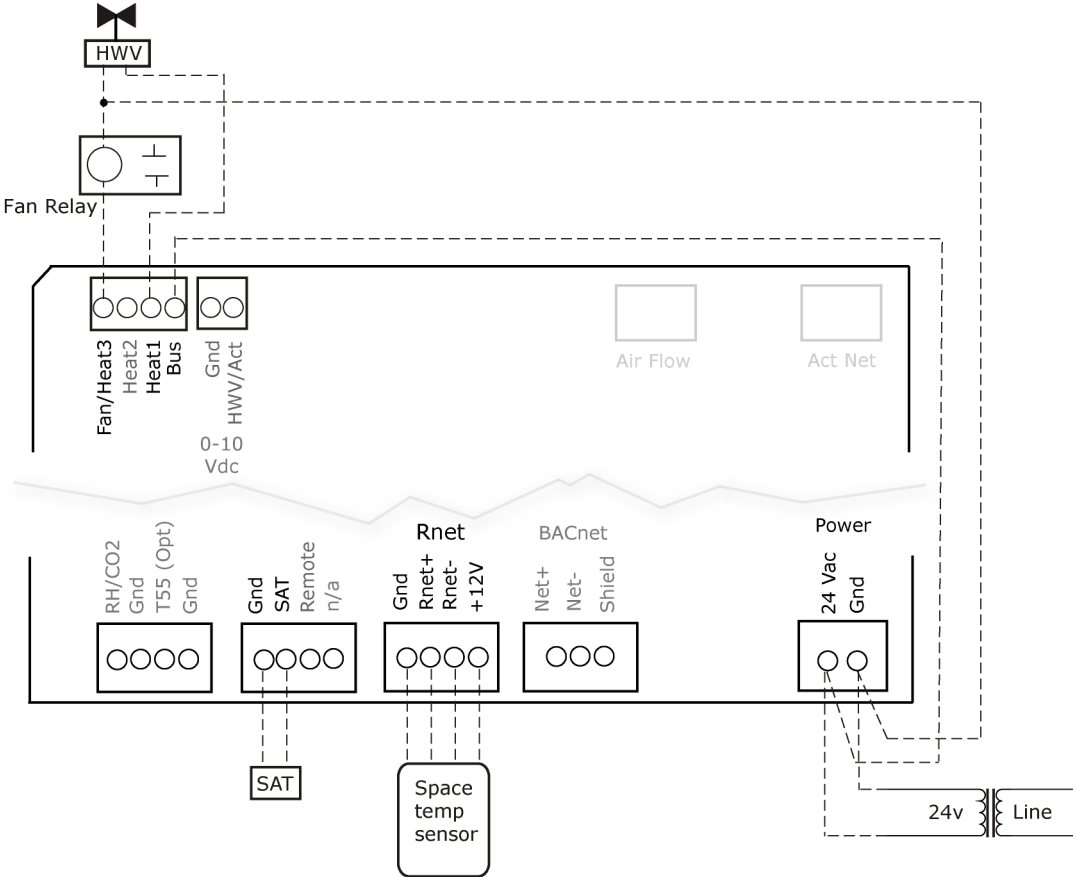

Modulating hot water (ducted or baseboard) - Fan box application

VAV Zone II Fan Terminal controller only

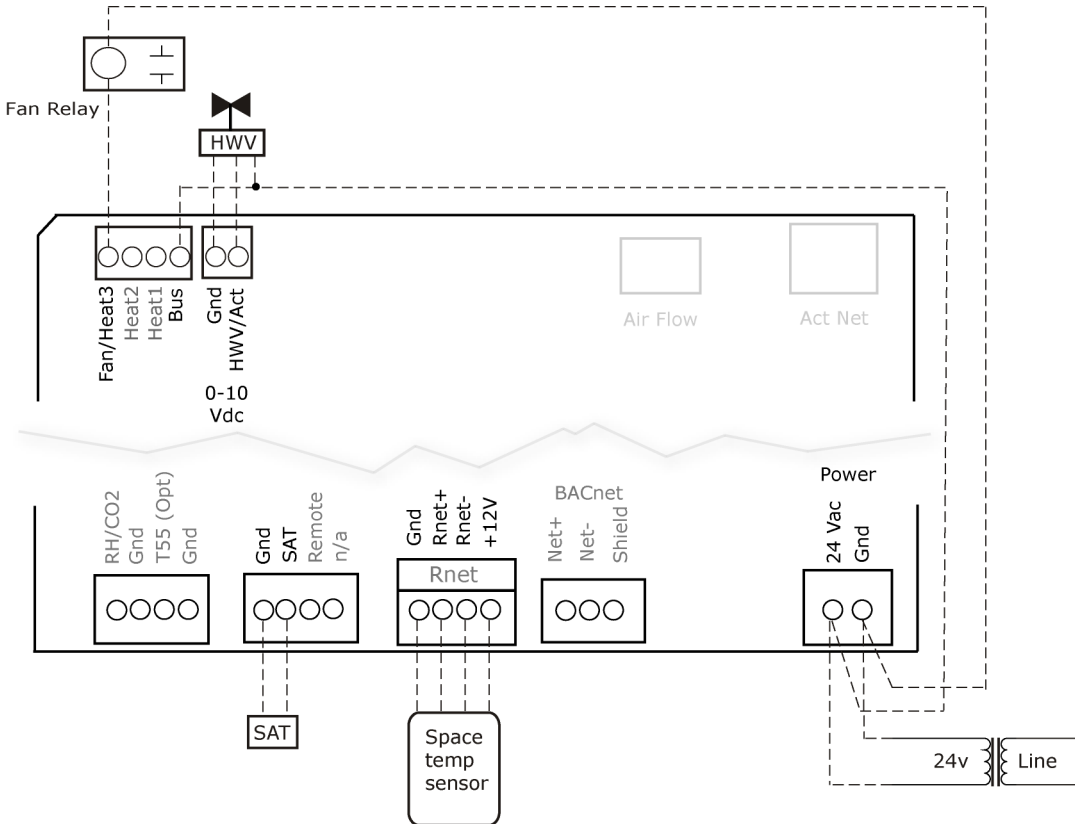

Combination heat (ducted electric heat with modulating baseboard heat) - Fan box application

VAV Zone II Fan Terminal controller only

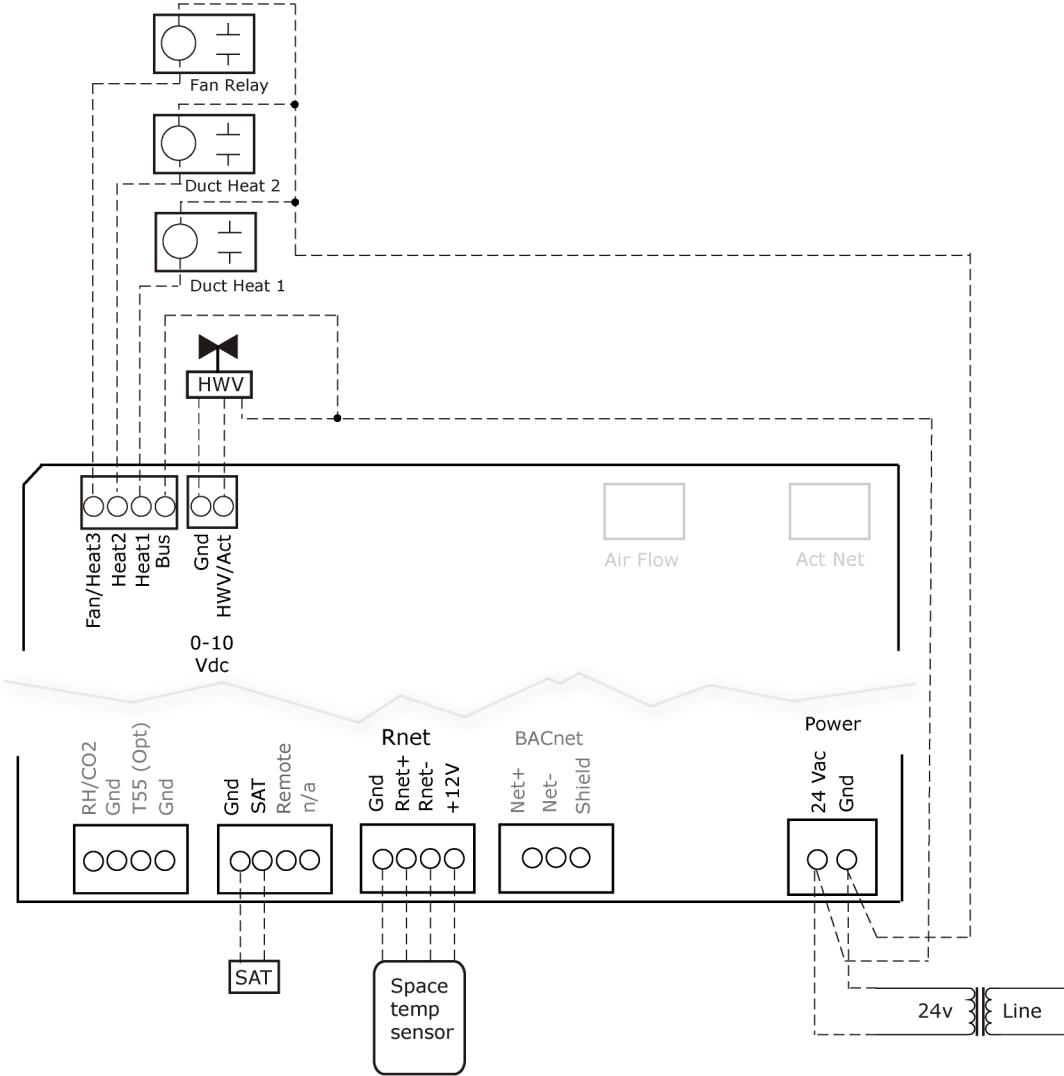

2-stage electric heat (ducted or baseboard) - Fan box application

VAV Zone II Fan Terminal Controller only

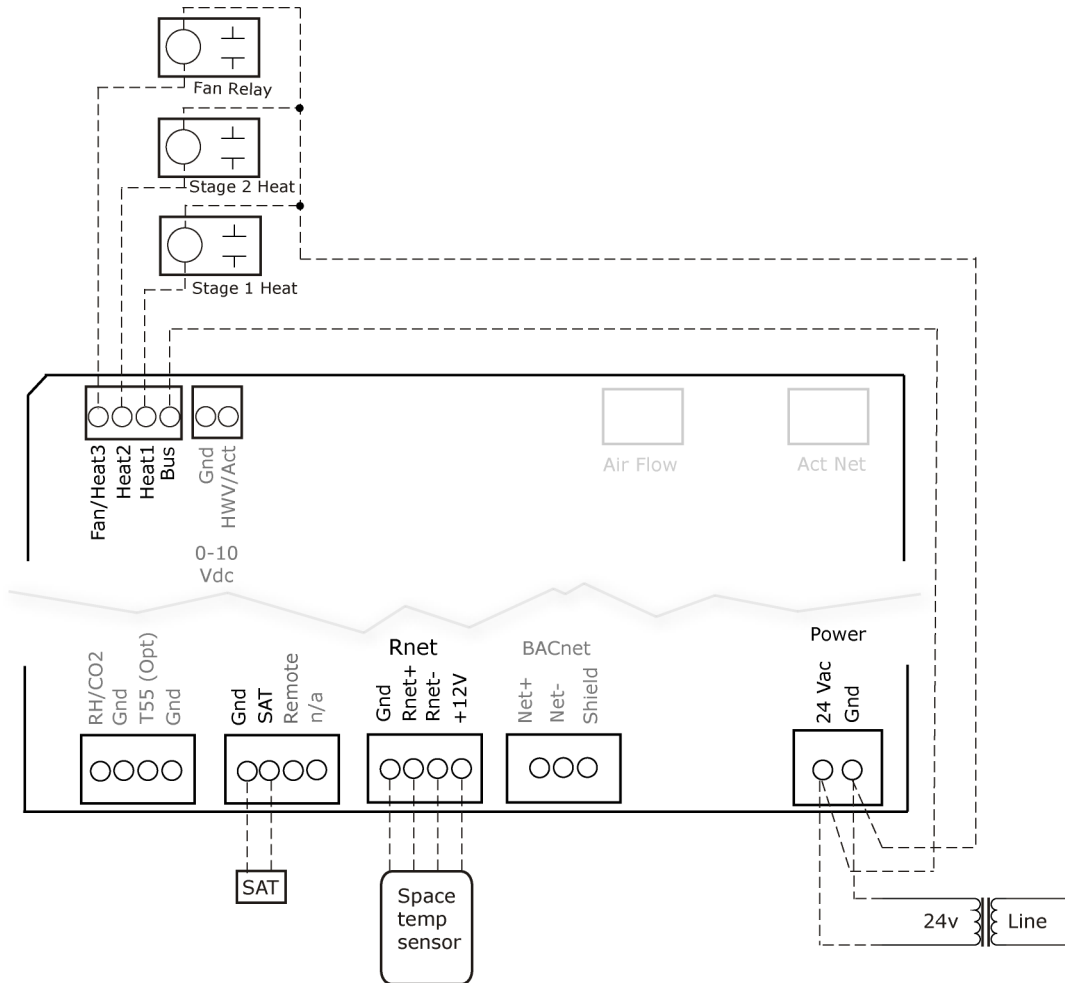

SCR electric heat (ducted or baseboard) - Single duct application

VAV Zone II Fan Terminal Controller

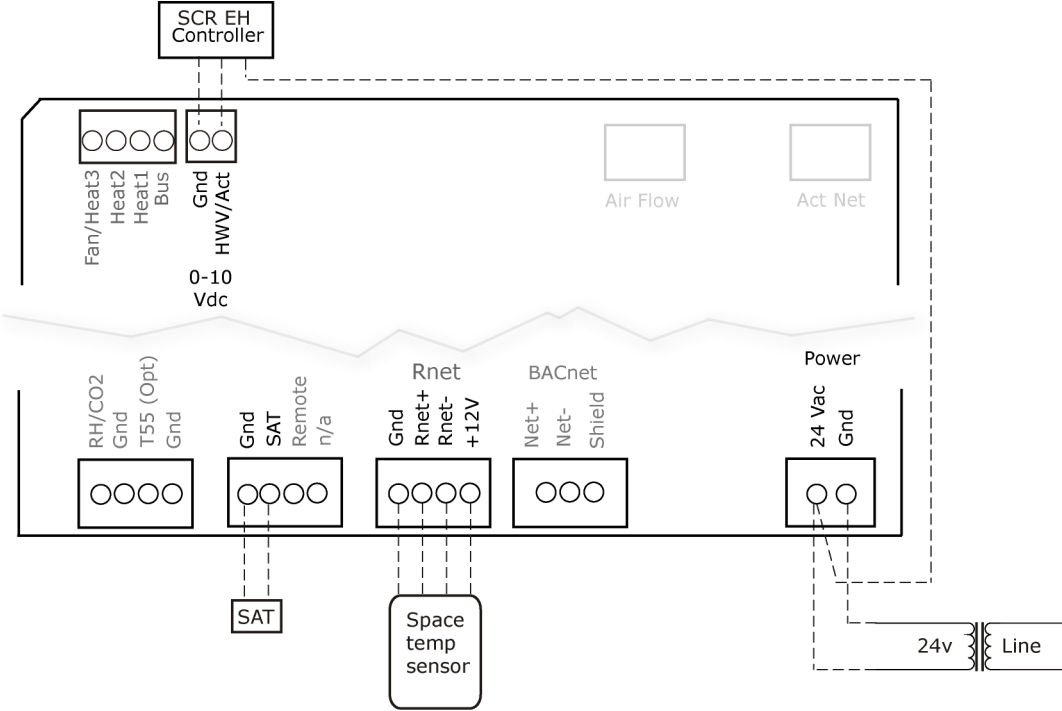

Wiring a field-supplied high-torque actuator to the analog output

You can wire one of the following Belimo actuators to the VAV Zone II's analog output instead of using the controller's built-in, 45 in.-lb (4 Nm) actuator.

NMX24-MFT P-10028	90 in.-lb (10 Nm) actuator with 0–10 Vdc control and 0–10 Vdc feedback
AMX24-MFT P-10028	180 in.-lb (20 Nm) actuator with 0–10 Vdc control and 0–10 Vdc feedback

- 1 Install the actuator according to the manufacturer's instructions.
- 2 Wire the actuator to the controller using the diagram below.

NOTE For proper operation and to prevent damage to the devices, use the same polarity for the actuator's power and the VAV Zone II's power.

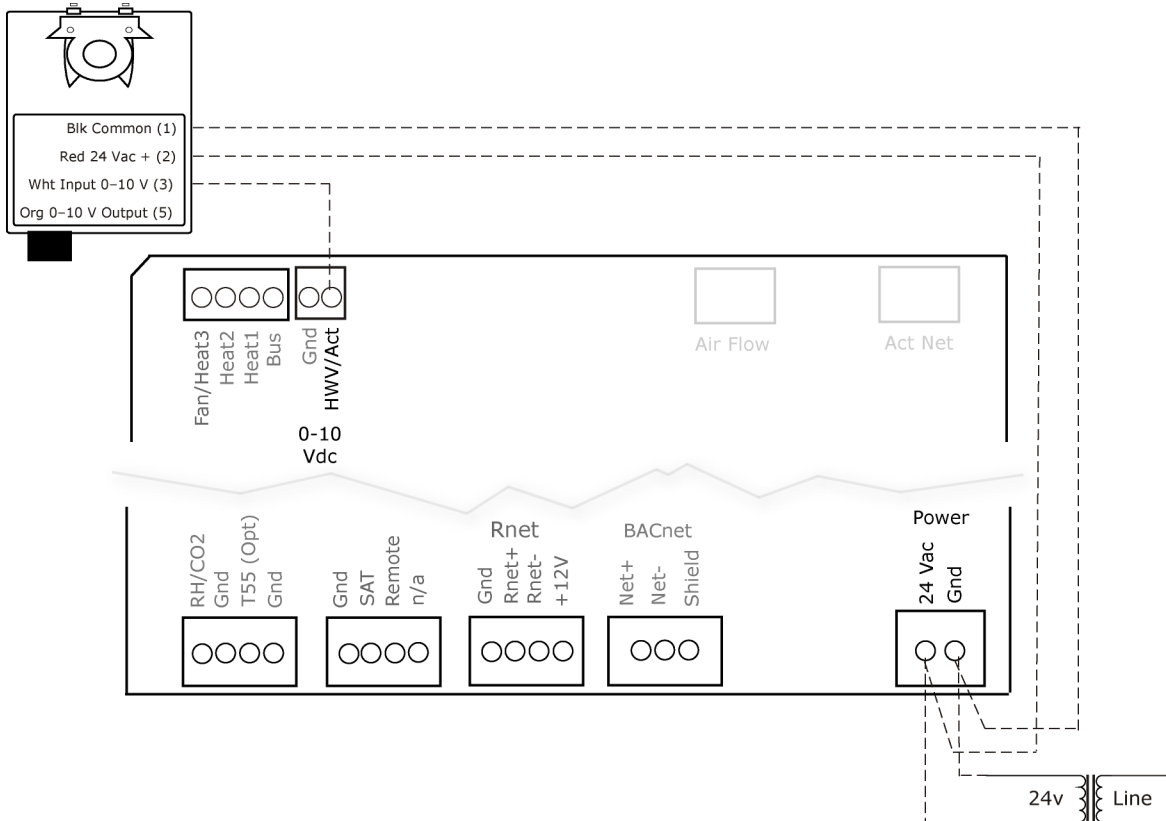

Start-up

Use one of the following interfaces to start up, access information, read sensor values, and test the controller.

This interface...	Provides a...
Field Assistant application - Runs on a laptop that connects to controller's Local Access port ¹	Temporary interface
Equipment Touch device - Connects to controller's Rnet port ²	Temporary or permanent interface
I-Vu® application Available for BACnet systems only	Permanent interface
System Touch device Available only for BACnet MS/TP systems. Wire to a BACnet MS/TP network connector and a 24 Vac power supply ³	Temporary or permanent interface

¹ Requires a USB Link (Part #USB-L).

² See the *Equipment Touch Installation and Setup Guide* for detailed instructions.

³ See the *System Touch Installation and Setup Guide* for detailed instructions.



CAUTION If multiple controllers share power but polarity was not maintained when they were wired, the difference between the controller's ground and the computer's AC power ground could damage the USB Link and the controller. If you are not sure of the wiring polarity, use a USB isolator between the computer and the USB Link. Purchase a USB isolator online from a third-party manufacturer.

Configuring the VAV Zone II's properties

To start up the VAV Zone II, you must configure certain points and properties. *Appendix A* (page 71) is a complete list of all the points and properties, with descriptions, defaults, and ranges. These properties affect the unit operation and/or control. Review and understand the meaning and purpose of each property before changing it.

- *Unit Configuration properties* (page 72)
- *Setpoint Configuration properties* (page 74)
- *Service Configuration properties* (page 83)
- *Linkage properties* (page 94)

See *Appendix A* (page 71) for a complete list of the controller's points/properties.

NOTE Engineering units shown in this document in the defaults and ranges are strictly for reference. You must enter an integer only.

Configuring ZS Sensors

The VAV Zone II automatically detects 1 ZS temperature sensor set to address (1). This sensor is labeled **Main ZS Sensor**.

You must configure the ZS Sensor properties in the i-Vu® application or Field Assistant as follows:

- Add more ZS temperature, humidity, or CO² sensors in the **Properties > Control Program** tab > **Service Configuration** section. Ctrl+click on the property name to open the microblock popup and configure the settings on the **Details** tab.

NOTE See *Service Configuration (page 83)* for details.

- Configuring the **ZS Sensor Binder**, and then the following as needed:
 - **ZS Zone Temp**
 - **ZS Zone Humidity**
 - **ZS Zone CO2**
 - **ZS model to show on graphic**
- Configure **Setpoint Adjustment**. See *Setpoints (page 74)*.
- Set **Occupancy** and **Override** properties. See *Maintenance (page 90)* for details.
- Alarm and Maintenance indications on the ZS Pro (display model) sensors. See *Appendix C: ZS Sensor display for VAV Zone II (page 101)*.

Performing system checkout

- 1 Verify that all power and communication connections are correct and tight.
- 2 Verify that all zone terminals, ductwork, and zone controllers are properly installed and set according to installation instructions and job requirements.
- 3 Verify that all air duct connections are tight.
- 4 Verify that zone terminal fans and system controls operate properly. Verify that actuator screws are properly tightened.
- 5 At the zone terminals, check electrical system and connections of any optional electric reheat coil. If hot water reheat is used, check piping and valves against job drawings.
- 6 Verify that all zone terminal dampers are fully open.
- 7 If using an air source with field-installed controls, make sure controls and sensors have been installed and wired per manufacturer installation instructions.
- 8 Verify that the air source motor starter and, if applicable, the Hand/Off/Auto (HOA) switch are installed and wired.
- 9 Verify that the area around the air source is clear of construction dirt and debris.
- 10 Verify that final filters are installed in the air handler(s). Dust and debris can adversely affect system operation.

- 11 Verify that the space sensor and all optional sensors are reading correctly.

NOTE You must use the i-Vu® application or Field Assistant to configure ZS Sensors.



CAUTION Before starting the air source fan, make sure the zone terminal dampers are not closed. Starting the fan with dampers closed will damage the system ductwork.

Commissioning the VAV Zone II

Using Field Assistant or the i-Vu® application:

- 1 Set damper size. Go to **Properties > Configuration > Service Configuration > Flow Control > Details** tab > **Manufacturer's specified air flow at 1" water column** and enter the correct cfm for the damper size.
- 2 Calibrate the damper travel.
 - a) Go to **Properties > Configuration > Service Configuration > Flow Control > Details** tab > **Test and Balance**. Click **Close Damper** and verify it goes to the closed position.
 - b) Click **Dampers Full Open** and verify it goes to the full open position.
 - c) Verify that the air source is off, and then calibrate the zero airflow reading at the terminal control. Click **Zero Flow** and verify the damper goes to the fully closed position and the airflow transducer is calibrated. Once the **Autozero complete** message is displayed, make sure the Measured Flow column under Calibration parameters for Zero Flow reads near zero cfm (liters/second) and the sensor reading should be less than 0.03.
 - d) Click **Automatic Control** to return the damper to normal operation.
- 3 For Parallel or Series Fan terminals – In the **Locks** section, select the **Fan's Lock value to** checkbox, then select **On** in the drop-down list. Click **Apply**. Verify the fan's operation.
- 4 For modulating hot water reheat – Go to **Properties > I/O Points** tab, then lock **Hot Water Valve** to 100%. If the controller is configured for Single Duct, make sure the air source fan is on. If ducted heat, verify the heat works by verifying that the SAT rises. For baseboard heat, physically check the heating element for proper temperature rise. Release the **Hot Water Valve**.
- 5 Release the fan.
- 6 If the controller is part of a linked system, verify **Linkage > Airside Linkage Status** shows **Active**.



CAUTION Pressing the actuator release button and moving the damper or disconnecting the actuator ribbon connector while the controller is powered will cause the damper position to be out of calibration. To recalibrate the damper position, you must perform steps 2a–2d above or power cycle the controller.

Balancing the system using the i-Vu®/Field Assistant applications

Most VAV system airflow designs are based on cooling requirements which require a greater cfm (liters/second) flow than heating requirements. Using this balancing procedure, you adjust the cooling airflow first. If the heating and cooling maximum airflow requirements are the same, you do not need to balance the heating airflow.

NOTE We recommend that the total heating minimum airflow settings for all the zones in the system be set to maintain the air source's design minimum heat cfm (liters/second) airflow across its heat exchanger to prevent damage to the equipment.

The following procedures instruct you to use the i-Vu® application or Field Assistant to balance the system. However, you can also use the Test & Balance tool that includes global commands to assist you in balancing the system.

Prepare for balancing

- 1 Log in to the i-Vu® application with an Administrator or Installer security level, or use Field Assistant.
- 2 Make sure the air source and its controller have been properly started and can run as a stand-alone unit.
- 3 Make sure you have addressed, commissioned, and started the zone and bypass controllers, if present.
- 4 If a manual damper is installed upstream of the zone damper, verify that it is fully open before any balancing occurs.
- 5 Verify that any zone controller supplying multiple diffusers has a manual balancing damper installed on each duct for balancing the design airflow through each diffuser.
- 6 Disable the air source heating and cooling outputs using one of the following methods:
 - Physically disconnect the air source controller's output wiring to the unit, then enable the fan.
 - In the i-Vu® or Field Assistant tree, select the AHU controller. Go to **Properties > Control Program** tab > **Enable/Disable** and enable **Test and Balance Command**.
- 7 Verify that the air source's supply static pressure setpoint is set to the system's design specification and that it does maintain the setpoint.

Balance each zone

- 1 In the i-Vu® or Field Assistant tree, select the zone controller that is physically closest to the air source. Go to **Properties > Control Program > Configuration > Service Configuration > Flow Control > Details** tab.
- 2 Do one of the following:
 - Single Duct or Parallel Fan zone terminals – Click **Cool Max Airflow** to override the zone control and increase the airflow to the cooling maximum cfm (liters/second) . Check the zone for design cooling maximum airflow using certified measuring devices. Enter the measured cfm (liters/second) and click the arrow to enter the current sensor reading value.
 - Series Fan zone terminals – Click **Damper Full Close** to override the zone damper to its fully closed position. Wait 30 seconds after the damper is closed, select the **Fan's Lock value to** checkbox, then select **On** in the droplist. Click **Apply**. You must follow this procedure to prevent the fan from turning backwards. Check the zone for design cooling maximum airflow using certified measuring devices. See the zone terminal manufacturer's instructions to adjust the fan speed to meet design airflow requirements. After you set the fan speed to deliver the **Cool Max Airflow**, click the **Cool Max Airflow**. Verify the airflow using a certified measuring device. Enter the measured cfm (liters/second) and press the arrow to enter the current sensor reading value. Verify that the zone terminal plenum air intakes do not have a positive airflow.
- 3 Check all branch duct terminal registers for design flow. If necessary, adjust the manual volume dampers in the branch ducts.
- 4 Single Duct or Parallel Fan zone terminals - Click **Occupied Min Airflow** to set the zone damper to its minimum airflow position. Verify the airflow using a certified measuring device. Enter the measured cfm (liters/second) and click the arrow to enter the current sensor reading value.
- 5 Parallel Fan Zone Terminals only - To adjust Parallel Fan airflow, make sure **Occupied Min Airflow** is selected, select the **Fan's Lock value to** checkbox, then select **On** in the drop-down list. Click **Apply**. See the zone terminal manufacturer's instructions on adjusting the fan speed to meet design airflow requirements. When finished, clear the **Fan's Lock value to** checkbox.
- 6 If the terminal has ducted reheat, select the **Flow Setpoint** in the **Locks** section and enter **Auxiliary Heat Min Airflow** if it is greater than the **Occupied Min Airflow**. Select **Auxheat** and enter 100%. Click **Apply**. Verify the supply air temperature rises for ducted heat. For non-ducted heat, physically verify that the heat is energized. Deselect a **Flow Setpoint** and **Auxheat** and click **Apply** when finished.
- 7 Repeat steps 1 through 6 for each zone until all zones have been balanced. Make sure that you select **Automatic Control** before moving on to the next zone.



Balancing the system using Test & Balance tool

Use the Test & Balance tool to manipulate the controllers associated with an air source, but not the air source itself or heating and cooling equipment such as chillers and boilers. See the Test & Balance Help for more information on using the tool.

Most VAV system airflow designs are based on cooling requirements which require a greater cfm (liters/second) flow than heating requirements. Using this balancing procedure, you adjust the cooling airflow first. If the heating and cooling maximum airflow requirements are the same, you will not need to balance the heating airflow.

NOTE We recommend that the total heating minimum airflow settings for all the zones in the system be set to maintain the air source's design minimum heat cfm (liters/second) airflow across its heat exchanger to prevent damage to the equipment.

To calibrate VAV Zone airflow

- 1 Select the VAV Zone air terminal in the tree.
NOTE You can select **View > Device ID** or **View > Primary Use** to show this information next to each item in the tree.
- 2 Select the **Test and Balance** tab.
NOTE If  or  appear on the status bar, see Air terminal calibration status to determine what you must do before calibration can occur.
- 3 Verify that the air source is off and that airflow has stopped.
- 4 Click **Zero Calibrate**.
NOTE The table below describes each damper command. Commands with a ☆ are required. Optional commands improve system accuracy. Do these in order from top to bottom for best results.
- 5 The status bar shows **Damper Moving**. Wait until it shows **Damper Ready**.
- 6 If the controller has an external actuator, do the following:
 - a) Type the **Measured Flow** in the fields beside **Zero Calibrate**.
 - b) Click the **Current Sensor Reading** button to copy the value to the **Sensor Reading** field, or type an adjusted value in the field.
- 7 Turn on the air source.
- 8 For each additional calibration step that you want to perform, do the following:
 - a) Click its Damper Command button.
 - b) Wait for **Damper Ready**.
 - c) Enter the **Measured Flow** and **Sensor Reading** as described in step 6.
- 9 Click **Apply** to send your changes to the controller and update the **Last Calibration Date** on the air source's page.
NOTE If desired, you can click **Apply** after each calibration step.
- 10 Remove any locks you have applied. See To view, lock, or unlock an air terminal function.
- 11 Click **Automatic** to return the controller to normal operation.

NOTES

- For **Cool Max**, **Heat Max**, and **Occupied Min** – When the setpoint is reached and stable, you can select **Lock damper at current open position** on the **Locks** tab to prevent damper movement while you take flow readings.
- You can repeat a calibration step to further calibrate the airflow sensor.
- An airflow sensor only reports air delivered from the air source. To adjust the cfm (liters/second) of variable speed fans in parallel VAV reheat, close the primary air damper.

Damper Command	Action
Zero Calibrate ☆	Closes the damper, takes a number of flow samples, then sets the zero calibration.
Damper Open	Opens damper fully and enables the Damper Open calibration fields.
Cool Max ☆	Forces the damper to its maximum cooling position. Calibration fields apply only if the primary use of this damper is cooling.
Occupied Min	Forces the damper to its minimum occupied position and enables the Occupied Min Flow calibration fields.
Damper Close	Forces the damper to its full closed position.
Heat Max	Forces the damper to its maximum heating position. Calibration fields apply only if the primary use of the damper is heating.
Automatic	Returns control of the damper to the control program. You must perform this step when you finish test and balance.

Upload calibration values to the i-Vu® application



CAUTION If your system has an i-Vu® user interface, you **must** run the Test and Balance report in the i-Vu® application after using VAV Zone II. Running the report uploads the values from the controller to the i-Vu® application. You will lose all your calibrations if you download to the controller in the i-Vu® interface before running this report.

- 1 In the i-Vu® interface, select the top level in the navigation tree.
- 2 Click **Reports > Commissioning > Test and Balance**.
- 3 On the **View** tab, click **Run**.

Go to Step 4: Run a report (Optional).

Run a report in VAV Zone II (Optional)

After balancing, you can run a report (.htm file) in Test & Balance that shows each controller's calibrated values and design values. You can view or edit the file in Microsoft Excel, Microsoft Word, or any web browser.

- 1 Select **Session > Report**.
- 2 Select an existing report or type a name in the **File Name** field.
- 3 Click **Save**.
- 4 If you chose an existing report in step 2, select **Append** to add to the report or **Overwrite** to replace the report.

Balancing the system

Most VAV system airflow designs are based on cooling requirements which require a greater cfm (liters/second) flow than heating requirements. Using the following balancing procedure, you adjust the cooling airflow first. If the heating and cooling maximum airflow requirements are the same, you do not need to balance the heating airflow.

Use the Test & Balance program to balance the system. Test & Balance can perform all the necessary functions, including shutting down the Linked air source and performing global commands to all zones in the system. You should do steps 1 through 4 in *Prepare for balancing* (page 48) prior to using Test & Balance. See Test & Balance's Help for details on the steps required to complete the balancing procedure.

NOTE We recommend that you set the heating minimum airflow settings for all the zones in the system to maintain the air source's design minimum heat cfm (liters/second) airflow across its heat exchanger to prevent damage to the equipment.

Prepare for balancing

- 1 Log in to the i-Vu® application with an Installer or Administrator role, or use Field Assistant.
- 2 Make sure the air source and its controller have been properly started and can run as a standalone unit.
- 3 Make sure you have addressed, commissioned, and started the zone and bypass controllers, if present.
- 4 Verify that zone controllers supplying multiple registers have manual dampers on each register branch duct for balancing the design airflow through each register.

Sequence of operation

The VAV Zone II supports 3 types of pressure-independent terminal configurations:

- Single duct
- Series fan-powered
- Parallel fan-powered

The controller can operate as part of a linked system (VAV or VVT) or as a stand-alone controller.

Temperature sensors

The VAV Zone II supports the following temperature sensors:

Sensors	Notes
Space temperature sensors:	
• Wireless Standard or Plus ¹	You can average up to 5 wireless sensors.
• ZS Standard, Plus, Pro ²	You can average up to 5 ZS sensors - a combination of temperature, humidity, and/or CO ² sensors.
• T55 ³	Push the sensor's override button from 2 to 10 seconds to initiate a timed override.
	If a network space temperature value is used, that value must be written to the BACnet space temperature point (system_spt) at 1 to 5 minute intervals or on a COV of 0.1Δ °F (.06Δ °C).
Supply Air Temperature (SAT) sensor	If the zone has ducted reheat, install an SAT sensor downstream of the reheat source. The SAT is used in controlling the reheat.
	If heat is not supplied, install the SAT sensor in the duct on the terminal's leaving air side.
	The SAT determines the air source mode should Linkage communication fail or if the controller is stand-alone. See <i>Air Source Mode Determination</i> (page 58) for details.

¹To configure the control program for the desired user interaction with the sensor, see the *Wireless Sensors Application Guide*. For detailed instructions, see the *Wireless Sensors Installation Guide*.

² For basic user instructions, see the *ZS Sensor User Guide*. For detailed installation instructions, see the *ZS Sensors Installation Guide*.

Zone airflow control

The VAV Zone II provides pressure-independent zone temperature control by modulating its damper actuator to control the flow of primary air into the zone. The controller uses PID control to calculate the airflow setpoint based on the air source mode and the difference between the zone's temperature and setpoints.

The air source mode determines if the primary air can meet the zone's need. If the zone controller is in a linked system, the air source mode is determined by the air source. If the zone controller is stand-alone or if linkage communication fails, the mode is determined by the controller's SAT sensor. See *Air source mode determination* (page 58). If the air source mode is the same as the zone's required mode, the damper is positioned so as to modulate the airflow setpoint between the mode's configurable minimum and maximum airflow based on the occupancy status of the zone. This minimum insures sufficient minimum airflow at the air source and sufficient ventilation to the zone during occupied periods.

Single duct with reheat – The **Auxiliary Heat Min Airflow** allows an increase of primary airflow across the terminal's ducted heating coil when the terminal operates its local heat. This provides the ability to lower the cooling minimum airflow limits while providing the necessary airflow when the terminal is heating to ensure design load conditions and electric heater minimum airflow.

VAV Reheat – Applicable only to single duct terminals with modulating or SCR Electric heat, when set to enable and reheat is required, the heating device is sequenced first to obtain the **Maximum Heating SAT** before any increase in airflow. When reheat starts, airflow is maintained at the configured minimum occupied value. Once the **Maximum Heating SAT** is reached and, if a further increase in heating capacity is required, then the airflow is increased as needed up to the configured **Auxiliary Heat Min Airflow** value.

Parallel fan terminals – The controller's **Parallel Fan On Value** determines when the fan turns on to increase airflow at the zone's diffusers and prevent cold air from dumping into the zone. This is achieved by increasing the volume and temperature of the air exiting the diffusers. If the zone's airflow control setpoint falls below the **Parallel Fan On Value**, the parallel fan turns on to mix ceiling plenum air with the primary air to increase total airflow and ventilation to the zone. The fan turns off when the airflow control setpoint rises above this value. If the zone requires heat while the AHU fan is off, the damper will close while heating is active to prevent reverse flow out through the terminal inlet.

The fan also starts in Heat mode if the zone is configured for ducted heat as described in *Zone reheat control* (page 51).

Series fan terminals – The fan turns on when the air source fan is on as determined by Linkage or in stand-alone operation by airflow monitoring (the fan is determined to be ON if the measured airflow increases above 20% of the **Cooling Max Airflow** or if the measured airflow is greater than 50% of the current airflow setpoint). When the air source starts operation, there is a fan start delay on transition to occupied, based on the **Power Fail Start Delay**. The terminal's damper fully closes and, after a 15 second delay, the fan starts. This prevents the fan from rotating backwards. Therefore, each series fan box should have a unique power fail restart delay to avoid closing all dampers simultaneously.

Damper Actuator(s) – The VAV Zone II's 45 in/lb (5 Nm) actuator has a 205 second full travel time for 90° operation. For field retrofit applications, the actuator can be adjusted for a damper stroke between 30° and 90°, and it can be configured to move clockwise (default) or counterclockwise.

If the built-in actuator's torque is insufficient for large damper applications, the VAV Zone II's analog output can drive an external, 0-10 volt, high-torque actuator.

Zone reheat control

The VAV Zone II can be configured for one of the following **Heat Types** to meet the zone's heating requirements:

- Modulating Hot Water/Steam
- Two Position Hot Water/Steam
- Staged Electric Heat (2 stages for VAVB3 with Series/Parallel Fan, 3 stages for Single duct. VAVB1 is 1 stage only.)
- Combination Modulating Baseboard/Staged Electric Heat (2 stages) (2 stages for VAVB3 with Series/Parallel Fan, 3 stages for Single Duct. VAVB1 is 1 stage only.)

All of the above except Combination Modulating Baseboard/Staged Electric Heat can be ducted or non-ducted (baseboard). For ducted type heat, the controller has a configurable **Maximum Heating SAT** for supply air temperature control. The controller monitors the SAT when the terminal's ducted heat operates.

If the network provides the OAT, heating can be disabled if the OAT rises above the configured **Heating Lockout Temperature**.

Modulating Hot Water / Steam Heating Heat – The controller modulates a normally closed or normally open hot water or steam valve connected to the discharge air heating coil. The valve opens and closes as needed to satisfy the zone's heating requirements. For ducted heat, the terminal's heat supplements any heat from the primary air source, but the terminal's SAT is controlled so that it does not exceed the **Maximum Heating SAT** (95° F [35° C] default). For baseboard heating (non-ducted heat), the valve modulates to keep the zone's temperature at the heating setpoint.

Two-Position Hot Water / Steam Heating Heat – The controller operates a normally closed or normally open hot water or steam valve connected to the discharge air heating coil. The valve opens and closes as needed to satisfy the zone's heating requirements. For ducted heat, the terminal's heat supplements any heat from the primary air source, but the terminal's SAT is controlled so that it does not exceed the **Maximum Heating SAT** (95° F [35° C] default). For non-ducted (baseboard) heating, the valve is controlled to keep the zone's temperature at the heating setpoint.

Electric Auxiliary Heat – The controller operates 1, 2, or 3 stages of electric heat. For ducted heat, the terminal's heat supplements any heat from the primary air source, but the terminal's SAT is controlled so that it does not exceed the **Maximum Heating SAT** (95° F [35° C] default). For non-ducted (baseboard) electric heat, the stages are controlled as needed to keep the zone's temperature at the heating setpoint.

SCR Electric Heat – The controller modulates an SCR heat output connected to the SCR electric heat control input. The output increases as needed to satisfy the zone's heating requirements. For ducted heat, the terminal's heat supplements heat from the primary air source, if it is in heating mode and is controlled so that the SAT does not exceed the **Maximum Heating SAT** (95° F [35° C] default). For baseboard heating (non-ducted heat), the SCR heat output modulates to keep the zone's temperature at the heating setpoint.

Combination Modulating Baseboard / Electric Heat – The controller can modulate a normally closed or normally open hot water or steam valve connected to a perimeter baseboard radiation system and control up to 2 stages of ducted electric heat. The valve modulates as needed to satisfy the zone's heating requirements. If the valve cannot meet the load, then the terminal's ducted electric heat is used. The terminal's electric heater supplements any heat from the primary air source, but the terminal's SAT is controlled so that it does not exceed the **Maximum Heating SAT** (95° F [35° C] default).

CV Modulating Heat – The controller can modulate a normally closed or normally open hot water or steam or steam valve connected to a perimeter baseboard radiation system or discharge air heating coil. The valve modulates as needed to keep the zone's temperature at the heating setpoint. For ducted applications, the terminal's SAT is controlled so that it does not exceed the **Maximum Heating SAT** (95° F [35° C] default). (Used primarily on single-duct terminals with ducted modulating hot water or steam heat in health care [hospital] applications, where discharge air temperature swings may be problematic. **CV Modulating Heat** may also be used in all non-ducted modulating heating applications.)

Parallel Fan Heat On Delay – For Parallel Fan terminals only, the controller has a configurable **Parallel Fan Heat On Delay** to save energy. During the delay period (15 minute default), only the fan operates to recycle heat from the ceiling plenum. If the heating requirement is not met by the end of the delay, the auxiliary heat is used.

Fan Heat Off Delay – For fan-powered terminals, the controller has a configurable **Fan Off Delay**. After the heating coil is de-energized, the fan continues to run for the length of the delay to deliver to the zone any heat stored in the coil. The default delay of 120 seconds is optimal for a ducted hot water coil. For ducted electric heat coils, the nominal delay is approximately 45 seconds. For baseboard and non-ducted heat, the delay should be set at 0.

This feature applies to parallel fan terminals in both occupied and unoccupied mode and series fan terminals in the unoccupied mode if the air source fan is off.

Demand control ventilation (DCV) and dehumidification using optional sensors

The VAV Zone II's **RH/CO2** input supports an optional CO2 sensor or Relative Humidity (RH) sensor. The sensor can have a 5-volt maximum output. The range is configurable as either 0–5 or 1–5 volts (1–5 volt supports 4–20 mA sensors with a 250 ohm resistor). The controller's low and high sensor input configuration allows for a wide range of sensors.

You can also connect ZS Sensors with CO₂ and/or RH to the VAV Zone II's **Rnet**. If you have more than one sensor, the controller determines DCV and dehumidification based on the highest sensor value and not the average. You can adjust this in the i-Vu application or Field Assistant.

The controller can also support both DCV and dehumidification functions by using a system RH or CO₂ sensor input connected to another controller.

NOTE If the connected sensor and/or system sensor value are to be used by the air source through Linkage, set the appropriate control type to **Enable**. If you do not need local control at the zone, set **DCV Max Vent Airflow** or **Maximum RH Override Airflow** to 0.

Demand Control Ventilation (DCV) – Requires CO2 sensor

The zone controller monitors the CO₂ sensor and can override the temperature control to respond to increasing CO₂ levels when the zone is occupied. If the sensor's value remains below the **DCV Start Ctrl Setpoint**, the **Occupied Min Airflow** setpoint provides the base ventilation rate as defined by ASHRAE. As the CO₂ level exceeds the **DCV Start Ctrl Setpoint** and the air source is in cooling or ventilation mode, the controller increases airflow to the zone starting at the **Occupied Min Airflow** and then proportionally increases ventilation as the CO₂ level increases. If the sensor's value exceeds the **DCV Max Ctrl Setpoint**, the controller maintains the **DCV Max Vent Airflow** until the zone's CO₂ level decreases.

When the zone is unoccupied, the **Unoccupied Min Airflow** provides the base ventilation as required.

If the controller is configured for auxiliary heat, the controller will maintain the zone's temperature at a heating setpoint that is temporarily increased to a value halfway between the heating and cooling setpoints when DCV is active. This prevents an excessive drop in zone temperature caused by the additional ventilation. If auxiliary heat is not available, the **DCV Max Vent Airflow** setpoint should be readjusted to prevent overcooling or set to 0 to disable DCV at the zone.

Dehumidification – Requires RH sensor

The zone controller monitors the RH sensor and can provide dehumidification if the sensor's value exceeds the **Occupied RH Control Setpoint** and the zone is occupied. If the zone is occupied, does not require heating, and the air source is operating in a cooling mode, the controller will override the temperature control to increase airflow to the zone. The primary air must have a sufficiently low dew point for dehumidification to function properly. During the dehumidification mode, the heating setpoint is temporarily increased to a value halfway between the heating and cooling setpoints to prevent overcooling in the zone. The controller uses a PID control loop to provide dehumidification. If auxiliary heat is not available, the **Maximum RH Override Airflow** should be readjusted to prevent overcooling or set to 0 to disable Dehumidification at the zone.

NOTE If both control functions are enabled, the zone will control to the greatest calculated minimum cfm (liters/second) airflow value of the three functions (temperature, RH, or IAQ).

Occupancy

The VAV Zone II's operation depends on the zone's occupancy state as determined by occupancy schedules or a remote occupancy override.

Occupancy Schedules – An occupancy schedule can be one of the following:

- A local schedule set up directly in the controller using a touchscreen or Field Assistant.
- A network schedule from an i-Vu® internal router. The VAV Zone II must be networked to an i-Vu® Open Router or an i-Vu® internal router.
- A **System Occupancy** network point. This point links the controller occupancy to another controller in the network so that multiple zones can follow the occupancy of another VAV Zone or other controller on the network.

To set up occupancy schedules, you first define a schedule for each day of the week and then define schedules for the exceptions, such as holidays. The exceptions can be based on a date, a date range, or a week and day.

NOTES

- The **Occupancy Schedules** property must be enabled (default).
- A network schedule downloaded from the i-Vu® application will overwrite a local schedule that was set up in a touchscreen or Field Assistant.

Remote Occupancy Override – The controller monitors its **Remote** input that is typically connected to the isolated, dry contact of an occupancy sensor located in the zone. (To use the occupancy override as described here, the **Standby Offset** value must be set to zero.) The controller can override the occupancy state based on whether or not the space is actually occupied. If the occupancy sensor contact is in the same state as **Occ Override Normal Logic State** setting, the zone follows its normal occupancy schedule. If the contact is in the opposite state, it overrides the zone into the unoccupied mode. The input can be configured for normally closed or normally opened contact types and is set to Open by default so that it does not affect the controller occupancy operation if left unused.

The **Remote** input can also be used to expand the setpoints during occupied periods without affecting the occupancy status of the zone. When the zone is occupied and the **Remote** input senses the occupant has left the zone, if a value greater than zero has been entered for the **Standby Offset**, then the occupied setpoints will be expanded by that number of degrees. This provides the ability to save energy but recover more rapidly rather than having the zone go unoccupied.

Learning Adaptive Optimal Start – This function gradually adjusts the unoccupied setpoints over a specified period of time to achieve the occupied setpoint by the time scheduled occupancy begins. This learning adaptive algorithm uses the **learned heating capacity** and **learned cooling capacity** values to calculate the effective setpoints prior to the occupied start time. The algorithm calculates a learned cooling and heating capacity during the previous unoccupied time. Set the **Learning Adaptive Optimal Start** recovery period from 1 to 4 hours in **Optimal Start**. When the **Learning Adaptive Optimal Start** routine runs, adjustments are based on the color that is achieved when occupancy begins. Adjustment amounts are defined in the thermographic color fields located directly above the **Effective Setpoints** graph under **Setpoints**.

BAS On/Off – This function allows third party control of the controller occupancy. **Occupancy Schedules** must be set to **Disable** to use this function. When set to **Occupied** or **Unoccupied**, **Optimal Start** is automatically disabled.

For additional information on ZS Sensor occupancy and override settings, see *Maintenance* (page 90) Points and Properties.

Alarms

Space Temp Sensor Alarm – The VAV Zone II monitors each space temperature sensor and the network input for space temperature. If no valid space temperature value is available, the controller generates an alarm and disables all local heating or cooling. The controller modulates the damper to the minimum heat, minimum cool, or ventilation position based on the air source mode. Normal operation resumes when the controller detects a valid sensor value.

Space Temperature Alarm – The controller generates an alarm if the space temperature exceeds the alarm setpoint. The occupied alarm setpoints are determined from the configurable **Occupied Alarm Hysteresis** ($5\Delta^{\circ}\text{F}$ [$2\Delta^{\circ}\text{C}$] default) which is subtracted from the configured occupied heat and added to the configured occupied cool setpoints. If the space temperature rises above or falls below this value and the condition lasts for more than 15 minutes, an alarm is generated. The configurable unoccupied high and low alarm setpoints have a fixed 10 minute alarm delay. When a transition from unoccupied to occupied occurs or the occupied temperature setpoints are changed, causing an immediate alarm condition, the controller automatically calculates an additional alarm delay equal to 10 minutes for each degree of change. This additional delay is added to the 15 minute fixed delay and allows the space temperature to recover and achieve the new setpoints, preventing unnecessary alarms. The space temperature alarm returns to normal when the space temperature again falls between the current mode's alarm setpoints.

Supply Air Temperature Alarm – The controller generates an alarm if the SAT exceeds the configured **High SAT Alarm Limit** (120°F [48.9°C] default) or falls below the **Low SAT Alarm Limit** (45°F [7°C] default) for more than 5 minutes. The hysteresis for return to normal is $3\Delta^{\circ}\text{F}$ ($1.6\Delta^{\circ}\text{C}$). The **High SAT Alarm Limit** should be set to a value at least $15\Delta^{\circ}\text{F}$ ($8.3\Delta^{\circ}\text{C}$) above the **Maximum Heating SAT** or the maximum discharge temperature from the air source, whichever is greater.

Space Relative Humidity Alarm – If **Optional Ctrl Type** is set to **RH Control** (Space Relative Humidity (RH) sensor is installed), the controller generates an alarm if the sensor's value exceeds the **Occ High RH Alarm Limit** (100% rh default) or the **Unocc High RH Alarm Limit** (100% rh default). The controller provides a 30-minute alarm delay during unoccupied periods. During occupied periods, the controller uses the **Occ High RH Alarm Limit**. When a transition from unoccupied to occupied occurs or the occupied high alarm limit is lowered causing an alarm condition to occur, the controller automatically calculates an alarm delay equal to 5 minutes for each % RH of change. This additional delay is added to the 15 minute fixed delay and allows the space relative humidity to recover and achieve the new setpoints, preventing unnecessary alarms.

Indoor Air Quality Alarm – If **Optional Ctrl Type** is set to **IAQ Control** (CO₂ sensor is installed), the controller generates an alarm during occupied periods if the sensor's value exceeds the **Occupied High CO₂ Alarm Limit**. When a transition from unoccupied to occupied occurs, or if the occupied alarm limit is changed to a value that causes an alarm condition to occur, the controller automatically calculates an alarm delay equal to 15 seconds for each ppm of change based on the error from setpoint (15 minutes minimum, 4 hours maximum). This delay prevents unnecessary alarms and gives the zone time to correct the alarm condition. To disable the IAQ alarm, set **Occupied High CO₂ Alarm Limit** to 0. The default value is 1100ppm. The hysteresis for return to normal is 100ppm.

Filter Alarm – For series or parallel fan-powered terminals, the controller monitors the accumulated hours of fan operation and generates an alarm when accumulated hours exceed the configured **Filter Service Alarm Timer** limit. The default value is 0 hours which disables the alarm. The alarm can be reset by setting **Reset Filter Alarm** to On or resetting the configured alarm limit to 0 hours.

Airside Linkage Alarm – The slave zone controller generates an alarm if it has once been linked successfully to a master zone and then it fails to receive linkage information for 5 minutes. If the controller is the VVT Master, it generates an alarm if it does not communicate with its air source for 5 minutes after having been previously communicating successfully. A return-to-normal is generated after successful Linkage communication resumes. A power cycle will reset and re-initialize the **Airside Linkage Alarm**.

The ZS Pro with display has alarm and maintenance indicators. See *Alarm Configuration* (page 81).

Demand limiting

Demand limiting is a cost-saving strategy to reduce energy consumption. The strategy expands the setpoints when the system reaches one of 3 levels of consumption. With the expanded setpoints, the equipment works less, thereby saving energy.

If the VAV Zone II receives a demand limit signal through the network, it expands its setpoints based on the demand level. The default amounts are:

- Demand Level 1: 1Δ °F (.6Δ °C)
- Demand Level 2: 2Δ °F (1.1Δ °C)
- Demand Level 3: 4Δ °F (2.2Δ °C)

Linkage

The i-Vu® Control System uses linkage to exchange data between the zone terminals and their air source to form a coordinated HVAC system. The system's air source controller, zone controllers, and bypass controller (if applicable) are linked so that their data exchange can be managed by one zone controller configured as the Master.

The basic linkage process is as follows:

- 1 The Master gathers data from the slave zone controllers such as occupancy status, setpoints, and zone temperature.
- 2 The Master performs mathematical calculations and algorithms on the data.
- 3 The Master sends the composite information to the air source.
- 4 The air source returns information such as mode, supply air temperature, and outside air temperature, if present.
- 5 The Master passes that information to all slave zone controllers.

The following sections detail the process for VAV Systems and VWT Systems.

VAV Systems

The VAV Master continuously scans the system and gathers the following information from each zone:

- Setpoints and zone temperature
- Zone size
- Occupancy status
- Damper position
- RH and CO₂ values (if applicable)

The VAV Master then does the following calculations and sends the results to the air source.

- If any zone is occupied, the system's occupancy status is set to occupied.
- If the system is occupied, it averages the space temperatures from all occupied zones using their normal terminal size at 1" (.249 kpa) VP to apply a weighting factor to that average (OCCSPT).
- It performs this same weighted average space temperature calculation for all the zones in the system (SPT).
- If no zone is occupied, it sets the occupied space temperature to "?". ("?" only displays on the **Details** tab of the Collector microblock and the Linkage status section of the **Properties** page.
- It calculates 4 weighted average setpoints:
 - the occupied heating weighted average setpoint (OHSP)
 - occupied cooling weighted average setpoint (OCSP)
 - the weighted average unoccupied heating setpoint (UHSP)
 - unoccupied cooling setpoint (UCSP).
- If the zones supply CO₂ or RH values, it calculates either a maximum or average value as determined by the configuration for each.

The air source determines its operating mode from the information received, and then sends the following to the Master:

- Air source mode
- Supply air temperature
- Outside air temperature
- Static pressure (if applicable)

The air source verifies the mode by comparing its supply air temperature to the space temperature received through linkage. See the air source documentation for operation and parameters used to verify its mode. This verification allows the system to verify that the stated air source mode is actually being provided. For example, if the air source heat has failed, the air source's actual mode would not indicate heat unless that mode was verified by the equipment's supply air temperature.

The VAV Master continuously evaluates all zones and processes their data as described above. The system switches modes only if the equipment mode changes.

VVT Systems

A VVT Master determines system operation by prioritizing heating and cooling requirements from all the zones based on their occupancy, demand, and damper size.

The VVT Master continuously scans the system to determine if any zones are occupied. If any zones are occupied, the VVT Master evaluates the occupied zones' heating or cooling demands to determine the following:

- The system mode. The mode is:
 - Cooling if the number of occupied zones with cooling demands exceeds the number of occupied zones with heating demands, and the demand is greater than or equal to the number of configured Linkage Callers.
 - Heating if the number of occupied zones with a heating demand exceeds or is equal to the number of Linkage Callers.
- The reference zone, the zone with the greatest demand for the system mode

If no zones are occupied or no occupied zones require heating or cooling, the VVT Master performs the evaluation described above for the unoccupied zones.

The VVT Master then sends the following information to the air source:

- The setpoints and zone temperature from the zone with the reference zone
- The system occupancy status
- Most open damper position from any zone
- RH and CO₂ values (if applicable)

The air source then sends to the VVT Master:

- The air source mode
- Supply air temperature
- Outside air temperature (if applicable)
- Static pressure (if applicable)

The air source verifies the mode by comparing its supply air temperature to the space temperature received through Linkage. See the air source documentation for operation and parameters used to verify its mode. This verification determines if the desired air source mode is being provided. For example, if the VVT Master requests heating but the air source does not have heat or its heat has failed, the verification indicates this. The actual current mode is sent to the zones so that they can control accordingly.

The system remains in that mode until all zones of that demand are satisfied or until the System Mode Reselect Timer (30 minute factory default) causes a forced re-evaluation of the system. If there is no demand for the opposite mode or the demand is smaller than the current mode, the reselect timer is reset to 30 and the current mode continues until all zones are satisfied or until the reselect timer expires, repeating the process. If there is a demand for the opposite mode, the VVT Master sends the new reference zone's space temperature and setpoints for the opposite mode to the air source and restarts the reselect timer. The air source re-evaluates this data and then attempts to provide the air required by the new information. The amount of time it takes to switch modes is determined by the air source's operating parameters.

The VVT Master continuously evaluates the system and updates the air source with the most current system demand. Based on the evaluation, the reference zone can change from one zone to another. The evaluation process continues until there is no demand from any zone or the 30 minute timer causes a re-evaluation of the system conditions.

If no heating or cooling is required or the current air source mode is satisfied, the VVT Master calculates:

- The weighted average of the occupied and unoccupied heating and cooling setpoints
- A zone temperature that is midway between the setpoints (occupied or unoccupied based on the system's current occupancy status).

This information, plus the occupancy status, is sent to the air source so that its current mode is disabled and the unit ceases heating or cooling operation. If the system is occupied, the air source fan and OA damper, if applicable, operate to maintain proper ventilation.

Linkage modes and determination

Linked air source modes – In a linked system, the air source determines its operating mode and qualifies that mode based on its own SAT. The following modes can be sent by the air source depending on its capability and configuration:

OFF	Air source fan is off. Terminal damper is positioned approximately 70% open to allow for system restart.
WARMUP	Air source fan is on and providing first cycle of heat when changing from unoccupied to occupied. It may also be used as an equipment safety to increase system airflow. The terminal's heating setpoint temporarily increases to the midpoint between the configured occupied heating and occupied cooling setpoints.
HEAT	Air source fan is on and providing heat. The terminal modulates its primary air damper to maintain the current heating setpoint.
FREECOOL	Air source fan is on and providing cooling using only the economizer and usually during an unoccupied period. The terminal modulates its primary air damper to maintain the midpoint between the configured occupied heating and occupied cooling setpoints.
COOL	Air source fan is on and providing cooling. The terminal modulates its primary air damper to maintain the current cooling setpoint.
PRESSURIZATION	Air source supply fan is on usually as a result of a fire-life safety input being active. It may also be used as an equipment safety to increase system airflow. The terminal modulates its primary air damper to provide the configured maximum cooling airflow.
EVACUATION	Evacuation is usually the result of a fire-life safety input at the air source being active. The terminal fully closes its primary air damper and disables its terminal fan, if equipped.
VENT	All terminals treat VENT mode the same as the COOL mode. For VVT terminals, VENT modes allows for an increase in airflow. VVT terminals use the greater of the configured Vent Damper Position or the Minimum Cooling Damper Position as the minimum during the VENT mode.

See the air source's installation manual for more specific operation.

Local air source modes – If the zone controller is stand-alone or if linkage communication fails, the zone controller monitors the cfm (liters/second) for fan status and its SAT sensor to determine if the primary air source is providing heating, cooling, or recirculating air in a fan-only or ventilation mode.

HEAT	For Series or Parallel Fan controllers when the zone terminal fan is off or for single duct controllers: The zone's local heat has not operated for at least 5 minutes, and the SAT is more than $5\Delta^{\circ}\text{F}$ ($2.8\Delta^{\circ}\text{C}$) warmer than the space temperature. If the terminal fan is on, the SAT must be more than $8\Delta^{\circ}\text{F}$ ($4.4\Delta^{\circ}\text{C}$) warmer than the space temperature. In all cases, Heat mode is maintained until the SAT drops $2\Delta^{\circ}\text{F}$ ($1.1\Delta^{\circ}\text{C}$) below the space temperature.
VENT	The zone's local heat has not operated for at least 5 minutes and the SAT is between 65°F (18.3°C) and 80°F (26.6°C).
COOL	The zone's local heat has not operated for at least 5 minutes, the current mode is not Heat, and the SAT is less than 65°F (18.3°).

OFF Terminal airflow is used determine if the primary air source fan is on or off. If the terminal's Damper Position is greater than 95% and the cfm (liters/second) is less than 10% of **Nominal CFM*** (liters/second) at 1" (.249 kpa) Velocity Pressure for 1 minute and the cfm (liters/second) Setpoint is not equal to 0, then the fan is determined to be off. If cfm (liters/second) is greater than 20% of the **Nominal CFM*** (liters/second) at 1" (.249 kpa) Velocity Pressure, or greater than 50% of cfm (liters/second) Setpoint for 10 seconds (whichever is greater), then the fan is determined to be on.

Occupied/Unoccupied Min CFM (liters/second) must be set for greater than 10% of Max Cool cfm (liters/second).

* Shown on **Properties** page as **Manufacturer's specified air flow at 1" water column:** for both English and Metric applications.

English: Use manufacturer's cfm at 1" water column

Metric: Use manufacturer's liters/second at .249 kpa

Design Parameters	
Cooling Max Airflow:	2100 cfm
Heating Max Airflow:	2100 cfm
Occupied Min Airflow:	315 cfm
Unoccupied Min Airflow:	315 cfm
Auxiliary Heat Min Airflow:	1680 cfm
Manufacturer's specified air flow at 1" water column:	2000 cfm
<input checked="" type="checkbox"/> Use supply air for heating when Heat Mode is ON	

NOTE A local air source fan mode of OFF usually cannot be detected on series fan boxes. This is because the terminal's series fan, when operating with the terminal damper open, usually creates enough primary airflow to prevent the control from properly detecting that the air source is off.

To adjust the driver properties

Use the following if you want to change the driver's properties in the i-Vu® interface.

- 1 On the i-Vu® navigation tree, right-click the VAV Zone II and select **Driver Properties**.
- 2 Make changes as needed on the **Properties** page for **Driver** and any of its children.

Driver

On the **Driver** page > **Settings** tab, you can change the Module clock synchronization and failure. See table below.

TouchScreen Control	
TouchScreen Schedule Edit Enable	This field is checked automatically to allow a user to edit this controller's schedules from an Equipment Touch's Schedules screen. Uncheck to disable.
Module Clock	
Clock Fall Date and Time	Date and time the control program uses when controller's time is invalid.  TIP Use an occupied date and time (such as a Tuesday at 10 a.m.) so the equipment does not operate in unoccupied mode if the controller loses power during occupancy.
Time Synch Sensitivity (seconds)	When the controller receives a time sync request, if the difference between the controller's time and the time sync's time is greater than this field's value, the controller's time is immediately changed. If the difference is less than this field's value, the controller's time is slowly adjusted until the time is correct.
Network Microblocks	
Number of poll retries before Network Input Microblocks indicate failure	The maximum number of retries after the initial attempt that a Network microblock will attempt to communicate with its target device. If unsuccessful, the point will transition to an idle state for 30 seconds before attempting to communicate again. Change this field only if directed by Technical Support.
Periodic rebinding interval	If a microblock uses a wildcard in its address, this timer determines how often the microblock will attempt to find the nearest instance of its target. For example, if an outside air temperature address uses a wildcard, a VAV application will look for the outside air temperature on the same network segment or on the nearest device containing that object.

BACnet COV Throttling**Enable COV Throttling**

Under normal circumstances, COV Throttling should be enabled to prevent excessive network traffic if an object's COV Increment is set too low. See EXCEPTION below.

When enabled, if an object generates excessive COV broadcasts (5 updates in 3 seconds), the driver automatically throttles the broadcasts to 1 per second. Also, if the object's value updates excessively for 30 seconds, an alarm is sent to the i-Vu® application listing all objects that are updating excessively. A Return-to-normal alarm is sent only after all objects have stopped updating excessively.

EXCEPTION: In rare circumstances, such as process control, a subscribing object may require COV updates more frequently than once per second. For these situations, clear this checkbox, but make sure that your network can support the increased traffic. You will also need to disable the **Excessive COV** alarms under the driver's **Common Alarms**.

Trend Sampling**Collect a daily midnight sample for all points in this controller that are sampling on COV**

For values that change infrequently, select to verify at midnight daily that the point is still able to communicate trend values.

Device

On the **Device** page, you can view the following properties:

- BACnet device object properties for the VAV Zone II
- VAV Zone II network communication

Configuration

NOTE The three APDU fields refer to all networks over which the VAV Zone II communicates.

Max Masters and Max Info Frames

Apply only if the VAV Zone II is on an MS/TP network.

Notification Classes

Alarms in the i-Vu® application use Notification Class #1. A BACnet alarm's Notification Class defines:

- Alarm priority for Alarm, Fault, and Return to Normal states
- Options for BACnet alarm acknowledgment
- Where alarms should be sent (recipients)

Priorities	NOTE BACnet defines the following Network message priorities for Alarms and Events.										
	<table border="1"> <thead> <tr> <th>Priority range</th> <th>Network message priority</th> </tr> </thead> <tbody> <tr> <td>00–63</td> <td>Life Safety</td> </tr> <tr> <td>64–127</td> <td>Critical Equipment</td> </tr> <tr> <td>128–191</td> <td>Urgent</td> </tr> <tr> <td>192–255</td> <td>Normal</td> </tr> </tbody> </table>	Priority range	Network message priority	00–63	Life Safety	64–127	Critical Equipment	128–191	Urgent	192–255	Normal
Priority range	Network message priority										
00–63	Life Safety										
64–127	Critical Equipment										
128–191	Urgent										
192–255	Normal										
Priority of Off-Normal	BACnet priority for Alarms.										
Priority of Fault	BACnet priority for Fault messages.										
Priority of Normal	BACnet priority for Return-to-normal messages.										
Ack Required for Off-Normal, Fault, and Normal	Specifies whether alarms associated with this Notification Class require a BACnet Acknowledgment for Off-Normal, Fault, or Normal alarms.										
	 TIP You can require operator acknowledgment for an Alarm or Return-to-normal message (stored in the i-Vu® database). In the i-Vu® interface on the Alarm > Enable/Disable tab, change the acknowledgment settings for an alarm source or an alarm category.										
Recipient List											
Recipients	The first row in this list is from the i-Vu® application. Do not delete this row. Click Add if you want other BACnet devices to receive alarms associated with this Notification Class.										
Recipient Description	Name that appears in the Recipients table.										
Recipient Type	Use Address (static binding) for either of the following: <ul style="list-style-type: none"> • Third-party BACnet device recipients that do not support dynamic binding • When you want alarms to be broadcast (you must uncheck Issue Confirmed Notifications). This use is rare. 										
Days and times	The days and times during which the recipient will receive alarms.										
Recipient Device Object Identifier	Type the Device Instance from the network administrator for third-party devices in the # field.										
Process Identifier	Change for third-party devices that use a BACnet Process Identifier other than 1. The i-Vu® application processes alarms for any 32-bit Process Identifier.										
Issue Confirmed Notifications	Select to have a device continue sending an alarm message until it receives delivery confirmation from the recipient.										
Transitions to Send	Uncheck the types of alarms you do not want the recipient to get.										

Calendars

Calendars are provided in the driver for BACnet compatibility only. Instead, use the **Schedules** feature in the i-Vu® interface.

Common Alarms

On these pages, you can enable/disable, change BACnet alarm properties, or set delays for the following BACnet alarms:

Common alarms:

- Module Halted
- All Programs Stopped
- Duplicate Address
- Locked I/O
- Control Program
- Program Stopped
- Excessive COV

Module Generated Alarm	
Description	Short message shown on the i-Vu® Alarms page or in an alarm action when this type of alarm is generated.
Events	
Alarm Category and Alarm Template	See <i>Alarms</i> in i-Vu® Help.
Enable	Clear these checkboxes to disable Alarm or Return to normal messages of this type from this controller.
Notification Class	Do not change this field.

To adjust the driver properties

Specific Events

On these pages, you can enable/disable, change BACnet alarm properties, or set delays for the following BACnet alarms:

Specific alarms:

- Flow Control Alarm
- Reheat Valve Alarm (future use)

NOTES

- To set up alarm actions for controller generated alarms, see *See Alarms* in i-Vu® Help.
- Reheat Valve Alarms are for future use.

Module Generated Alarm	
Description	Short message shown on the i-Vu® Alarms page or in an alarm action when this type of alarm is generated.
Events	
Alarm Category and Alarm Template	See <i>Alarms</i> in i-Vu® Help.
Enable	Clear these checkboxes to disable Alarm or Return to normal messages of this type from this controller.
Notification Class	Do not change this field.

Switches, Jumpers, Options

The **Switches, Jumpers, Options** page shows the current physical settings on the VAV Zone II.

Flow Calibration Archive

The **Flow Calibration Archive** page shows measured flow and sensor readings that were entered in the i-Vu® Test and Balance tool.

Act Net Network Details

Act Net Statistics

The actuator serial numbers are automatically read and filled in by the i-Vu® application. Only those devices that are physically connected or in the control program will show in the table.

NOTE See *To get the Carrier VAV Zone II serial number* (page 67) for the controller serial number.

The **Act Net** network shows the VAV Zone II's actuator has Address **1**.



CAUTION If you see **Duplicate address on network** or **No communication with device** under **Device Status**, contact Carrier Control Systems Support. Do not use **Act Net Address Setting** unless directed by Carrier Control Systems Support.

Troubleshooting

If you have problems mounting, wiring, or addressing the VAV Zone II, contact Carrier Control Systems Support.

NOTE To help you troubleshoot, obtain a Module Status (Modstat) from the controller and review the System Error and Warning details.

LED's

The LED's on the VAV Zone II show the status of certain functions. Verify the LED patterns by cycling power to the controller and noting the lights and flashes.

If this LED is on...	Status is...
Power	The VAV Zone II has power.
Rx	The VAV Zone II is receiving data from the network segment
Tx	The VAV Zone II is transmitting data over the network segment
DO#	The digital output is active
CW	The actuator motor is turning clockwise
CCW	The actuator motor is turning counterclockwise

The **Run** and **Error** LED's indicate controller and network status.

If Run LED shows...	And Error LED shows...	Status is...
1 flash per second	1 flash per second, alternating with the Run LED	The controller files are archiving. Archive is complete when Error LED stops flashing.
2 flashes per second	Off	Normal
2 flashes per second	2 flashes, alternating with Run LED	Five minute auto-restart delay after system error
2 flashes per second	3 flashes, then off	The controller has just been formatted
2 flashes per second	4 flashes, then pause	Two or more devices on this network have the same network address
2 flashes per second	1 flash per second	The controller is alone on the network
2 flashes per second	On	Exec halted after frequent system errors, due to: <ul style="list-style-type: none"> • Controller halted • Program memory corrupted • One or more programs stopped
5 flashes per second	On	Exec start-up aborted, Boot is running

If Run LED shows...	And Error LED shows...	Status Is...
5 flashes per second	Off	Firmware transfer in progress, Boot is running
7 flashes per second	7 flashes per second, alternating with Run LED	Ten second recovery period after brownout
14 flashes per second	14 flashes per second, alternating with Run LED	Brownout
On	On	Failure. Try the following solutions: <ul style="list-style-type: none"> • Turn the VAV Zone II off, then on. • Download memory to the VAV Zone II. • Replace the VAV Zone II.

NOTE If you resolve the issue but the **Error** LED does not turn off, cycle power to the controller.

To get the serial number

If you need the VAV Zone II's serial number when troubleshooting, the number is on a Module Status report (Modstat) under **Core** (or **Main**) **board hardware**

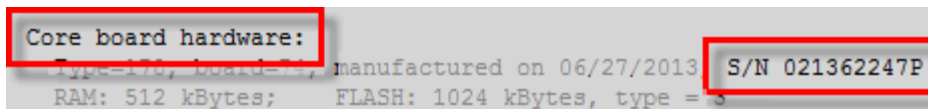

To obtain a modstat in the i-Vu® interface:

- 1 Select the VAV Zone II in the navigation tree.
- 2 Right-click and select **Module Status**.

To restore factory defaults

CAUTION This erases all archived information and user-configuration settings. You will have to reconfigure all custom settings. It is recommended to restore the factory defaults only under the guidance of Carrier Control Systems Support.

To erase volatile memory data and restore factory default configuration settings:

- 1 Pull the screw terminal connector from the controller's power terminals labeled **Gnd** and **24 Vac**. Make sure the address switches are not set to 0, 0.
- 2 Short the **Format Short pins** jumper's pins and maintain the short for steps 3 and 4.
- 3 Insert the power screw terminal connector into the VAV Zone II's power terminals.

- 4 Continue to short the jumper until the **Error** LED flashes three times in sync with the **Run** LED.
- 5 Remove the short.

To replace the battery

If the VAV Zone II experiences a power outage and the control program stops functioning, replace the battery.

You need to replace the battery if the voltage measures below 2.9 volts when the controller is not powered.

- 1 Verify that the VAV Zone II's power is on.



CAUTION If the controller's power is not **on** when replacing the battery, your date, time, and trend data will be lost.

- 2 Remove the VAV Zone II's cover.
- 3 Remove the battery from the controller, making note of the battery's polarity.
- 4 Insert the new battery, matching the battery's polarity with the polarity indicated on the controller's cover.
- 5 Replace the VAV Zone II's cover.
- 6 Download the VAV Zone II.

To clean the airflow sensor orifice

In less than .02% of installations, small particulates (micron/submicron-level) can build up in the airflow sensor's internal orifice causing airflow restriction. Symptoms of airflow restriction are:

- Diffuser noise increases over time
- Space overcools at minimum airflow
- Frequency of dampers opening to maintain flow setpoint increases over time
- AHU fan speed increases over time

To check for these symptoms, set up trending of:

- Damper position to look for long term increase
- AHU fan speed for maintaining static pressure

If you see these symptoms, you should clean the flow sensor.

To clean the flow sensor

You can use a can of compressed air to clean the sensors while the controller is installed or on a repair bench.

- 1 Disconnect the **High** and **Low** flow sensor tubes.
- 2 Insert the compressed air straw 1/4" into the controller's **High** connector.

 **WARNING** The compressed air can **MUST** be upright. It will damage the flow sensors by producing ice crystals if the can is on its side.

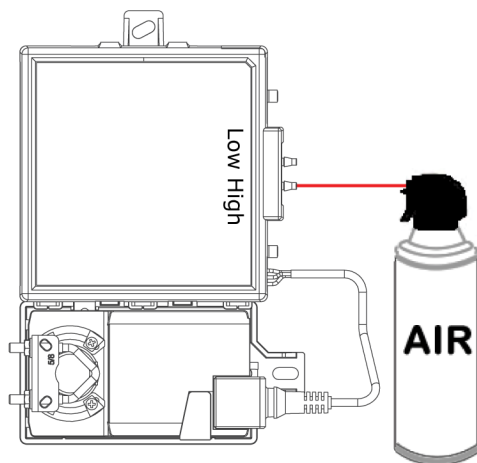

- 3 Press the air can's trigger twice for no more than 2 seconds each time.
- 4 Reconnect tubing to the **High** and **Low** flow sensor tubes.

Compliance

FCC Compliance

This device complies with Part 15 of the FCC Rules. Operation is subject to the following two conditions:

- 1 This device may not cause harmful interference.
- 2 This device must accept any interference received, including interference that may cause undesired operation.



IMPORTANT Any changes or modifications not expressly approved by manufacturer could void the user's authority to operate the equipment.

NOTE This equipment has been tested and found to comply with the limits for a Class B digital device, pursuant to Part 15 of the FCC Rules. These limits are designed to provide reasonable protection against harmful interference when the equipment is operated in a residential installation. This equipment generates, uses, and can radiate radio frequency energy, and if it is not installed and used in accordance with this document, it may cause harmful interference to radio communications. However, there is no guarantee that interference will not occur in a particular installation. If this equipment does cause harmful interference to radio or television reception, which can be determined by turning the equipment off and on, the user is encouraged to try to correct the interference by one or more of the following measures:

- Reorient or relocate the receiving antenna.
- Increase the separation between the equipment and receiver.
- Connect the equipment into an outlet on a circuit different from that to which the receiver is connected.
- Consult the dealer or an experienced radio/TV technician for help.

CE Compliance



WARNING This is a Class B product. In a light industrial environment, this product may cause radio interference in which case the user may be required to take adequate measures.

BACnet Compliance

Compliance of listed products to requirements of ASHRAE Standard 135 is the responsibility of BACnet International. BTL® is a registered trademark of BACnet International.

Appendix A: VAV Zone II Points/Properties

NOTE Engineering units shown in this document in the defaults and ranges are strictly for reference. You must enter an integer only.

Status

Navigation: i-Vu® / Field Assistant: **Properties > Control Program > Status**

Point Name/Description	Range
Terminal Mode – The controller's current operating status.	R: Off Heating Warm-up Vent Cooling Dehumidify Reheat Pressurize Evacuate Shutdown IAQ Override Air Balancing
Term Type – The type of zone terminal that the controller is installed on.	R: Single Duct Parallel Fan Series Fan
Space Temperature - Prime Variable – The space temperature value currently used for control.	R: -56 to 245 °F (-48.9 to 118.3 °C)
Primary Airflow – The current airflow measured through the primary air damper.	R: 0 to 99999 cfm (liters/second)
Damper Position – The current damper position.	R: 0 to 100%
Supply Air Temperature – Displays the current supply air temperature.	R: -56 to 245 °F (-48.9 to 118.3 °C)
Heating Capacity – The current reheat capacity when the zone is configured for reheat.	R: 0 to 100%
Baseboard Heating Capacity – The current baseboard heat capacity when the zone is configured for Combination Baseboard or Non-ducted Heat.	R: 0 to 100%
Outdoor Air Temperature – The current outdoor air temperature from a linked air source, if available, or from another network source.	R: -56 to 245 °F (-48.9 to 118.3 °C)
Fan – The status of the terminal fan if Term Type is Parallel Fan or Series Fan .	R: On/Off
Space Relative Humidity – The current space relative humidity if Service Configuration > Hardwired Sensor is set to RH Sensor or, you have a valid ZS RH sensor.	R: 0 to 100%rh
Indoor Air Quality CO2 (ppm) – The current IAQ value if Service Configuration > Hardwired Sensor is set to CO2 Sensor or, you have a valid ZS CO2 sensor.	R: 0 to 5000ppm

Point Name/Description	Range
Shutdown – When Active , disables all control functions, at normal equipment time delays and maintains minimum airflow.	D: Inactive R: Inactive/Active

Unit Configuration

Navigation: i-Vu® / Field Assistant: **Properties > Control Program > Configuration > Unit Configuration**

Point Name/Description	Default/Range
Heat Enable – Enables the reheat function.	D: Enable R: Disable/Enable
Parallel Fan Heat On Delay – Parallel type terminal only. The delay before reheat is enabled after the zone has a heating demand. The terminal fan runs immediately and attempts to meet the heating demand using the heated air from the ceiling plenum.	D: 15 min R: 0 to 60 min
Fan Off Delay – Fan-type terminals only. The amount of time the terminal fan continues to operate after a heating demand is satisfied.	D: 120 seconds R: 0 to 180 seconds
Maximum Heating SAT – The maximum supply air temperature allowed while ducted heat is operating. Ducted type supplemental heat is controlled so that it will not exceed this limit or the configured High SAT Alarm Limit . Set the Maximum Heating SAT limit to 5°F (2.8°C) above the desired maximum supply air temperature you would expect. Refer to Alarm Configuration > High SAT Alarm Limit to properly set this parameter.	D: 95°F (35°C) R: 80 to 140°F (26.6 to 60°C)
Maximum RH Override Airflow – The maximum airflow allowed when the RH function overrides the temperature control. When active, the damper modulates to the temperature control requirement or the RH override airflow, whichever is greater. This value is the percentage of the Maximum Cooling Airflow Setpoint .	D: 60% R: 0 to 100%
DCV Max Vent Airflow – The maximum airflow allowed when the IAQ function overrides the temperature control. When active, the damper modulates to the temperature control requirement or the DCV Max Vent Airflow , whichever is greater. This value is a percentage of the Maximum Cooling Airflow Setpoint .	D: 70% R: 0 to 100%
Filter Service Alarm Timer – Fan type terminals only. The amount of time the fan will run before generating a Filter Alarm . Set to 0 to disable the alarm.	D: 0 hr R: 0 to 9999 hr
T55 Pushbutton Override – Enables or disables the use of a pushbutton override from a local space temperature sensor.	D: Enable R: Disable/Enable
Setpoint Adjustment – Enables or disables the setpoint adjustment mechanism on the local space sensor.	D: Enable R: Disable/Enable

Point Name/Description	Default/Range
Setpoint Adjustment Range - The maximum amount that a user can adjust the setpoint on the local ZS or SPT sensor.	D: 2Δ°F (1.1Δ°C) R: 0 to 5Δ°F (0 to 2.7Δ°C)
Heating Lockout Temperature – Supplemental reheat is disabled if outside air temperature exceeds this value. Supplemental reheat is enabled when the outside air temperature falls below a fixed hysteresis of 2Δ°F (1.1Δ°C). This function is active only if there is a valid network outside air temperature.	D: 70°F (21.1°C) R: 35 to 150°F (1.6 to 65.5°C)
Power Fail Restart Delay – How long the controller delays normal operation after the power is restored. This is typically used to prevent excessive demand when recovering from a power failure. Applies to Series Fan start delay when system mode transitions from unoccupied to occupied. A delay of no greater than 120 seconds is recommended for Series Fan applications.	D: 60 seconds R: 0 to 600 seconds
Occupancy Schedules – If Enabled , the controller stores and follows a schedule sent over the network or programmed locally through a touchscreen or Field Assistant. If Disabled , the controller occupancy is controlled from the BAS On/Off or System Occupancy network point.	D: Enable R: Disable/Enable
Occ Override Delay – The amount of time the controller remains occupied after the remote occupancy switch returns to the unoccupied position.	D: 15 minutes R: 0 to 240 minutes
T55 Override Duration – The amount of time that the controller runs in the occupied mode when a user presses the T55 sensor's override button for 1 to 10 seconds. Pushbutton Override must be set to Enable .	D: 1 hr R: 1 to 4 hr
Local Sensor Calibration	
Space Temperature – The current space temperature.	R: -56 to 245°F (-48.9 to 118.3°C)
Space Temp Calibration – A calibration offset value to allow the local space temperature sensor to be adjusted to match a calibrated standard measuring the temperature in the same location.	D: 0Δ°F/Δ°C R: -9.9 to 10Δ°F (-5.5 to 5.5Δ°C)
Supply Air Temperature – Displays the current supply air temperature.	R: -56 to 245°F (-48.9 to 118.3°C)
Supply Air Temp Calibration – A calibration offset value to allow the supply air temperature sensor to be adjusted to match a calibrated standard measuring the temperature in the same location.	D: 0Δ°F/Δ°C R: -9.9 to 10Δ°F (-5.5 to 5.5Δ°C)
Space Relative Humidity – Displays the current value of relative humidity sensor, if present.	R: 0 to 100%
Relative Humidity Calibration – You can enter a calibration offset for the relative humidity. The offset is added to or subtracted from the controller's RH input value, and the calculated value is shown in the Status > Space Relative Humidity .	D: 0% R: -15 to 15%rh

Setpoints

Navigation: i-Vu® / Field Assistant: **Properties > Control Program > Configuration > Setpoints**

Select a color band on the setpoint graph to see the current setpoints in the **Heating** and **Cooling** fields. The values in this graphic are Fahrenheit. See setpoint descriptions below.

NOTE This graphic is an example only. Your setpoints may differ.

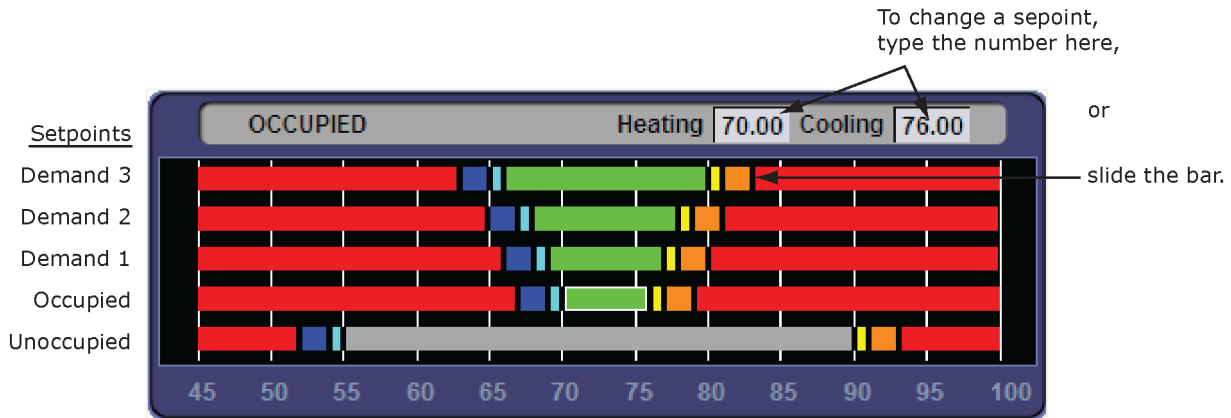

Occupied Setpoints

The occupied setpoints described below are the setpoints under normal operating conditions. The Demand Level 1–3 setpoints apply if demand limiting is used.

Demand limiting is a cost-saving strategy to reduce energy consumption. The strategy expands the occupied heating and cooling setpoints when the system reaches one of 3 levels of consumption. With the expanded setpoints, the equipment works less, thereby saving energy. By default, Demand Level 1 expands the occupied heating and cooling setpoints by 1Δ°F (Δ.5°C), Demand Level 2 by 2Δ°F (1.1Δ°C), and Demand Level 3 by 4Δ°F (2.2Δ°C). If the occupied heating or cooling setpoints change, the (effective) demand level setpoints automatically change by the same amount. See *Sequence of Operation* (page 49) for more information.

Point Name/Description	Default			
	Range: -40 to 245 °F (-40 to 118.3 °C)			
	Occupied	Demand Level		
		1	2	3
Occupied Heating – Green The heating setpoint the controller maintains while in occupied mode.	D: 70 °F (21.1 °C) R: 40 to 90 °F (4.4 to 32.2 °C)	69 °F (20.5 °C)	68 °F (20 °C)	66 °F (18.9 °C)
Occupied Cooling – Green The cooling setpoint the controller maintains while in occupied mode.	D: 76 °F (24.4 °C) R: 55 to 99 °F (12.7 to 37.2 °C)	77 °F (25 °C)	78 °F (25.5 °C)	80 °F (26.6 °C)

Point Name/Description	Default			
	Range: -40 to 245 °F (-40 to 118.3 °C)			
	Occupied	Demand Level		
1		2	3	
Occupied Heating 1 – Light Blue The space temperature must be less than the Occupied Heating 1 setpoint for the VVT Master to consider the zone a heating caller in a linked system. In a single-zone application, the heating requirement begins as soon as the space temperature falls below the Occupied Heating setpoint. We recommend that the Occupied Heating 1 value be set no less than 0.5Δ °F (.27Δ °C) below the Occupied Heating setpoint.	69 °F (20.5 °C)	68 °F (20 °C)	67 °F (19.4 °C)	65 °F (18.3 °C)
Occupied Heating 2 – Dark Blue The space temperature must be less than the Occupied Heating 2 setpoint to generate a low space temperature alarm. We recommend that this value be set no less than 0.5Δ °F (.27Δ °C) below the Occupied Heating 1 setpoint.	67 °F (19.4 °C)	66 °F (18.9 °C)	65 °F (18.3 °C)	63 °F (17.2 °C)
Occupied Cooling 1 – Yellow The space temperature must be greater than the Occupied Cooling 1 setpoint for the VVT Master to consider the zone a cooling caller in a linked system. In a single-zone application, the cooling requirement begins as soon as the space temperature exceeds the Occupied Cooling setpoint. We recommend that the Occupied Cooling 1 value be set no less than 0.5Δ °F (.27Δ °C) above the Occupied Cooling setpoint.	77 °F (25 °C)	78 °F (25.5 °C)	79 °F (26.1 °C)	81 °F (27.2 °C)
Occupied Cooling 2 – Orange The space temperature must be greater than the Occupied Cooling 2 setpoint to generate a high space temperature alarm. We recommend that this value be set no less than 0.5Δ °F (.27Δ °C) above the Occupied Cooling 1 setpoint.	79 °F (26.1 °C)	80 °F (26.6 °C)	81 °F (27.2 °C)	83 °F (28.3 °C)

Unoccupied Setpoints

Point Name/Description	Default/Range
Unoccupied Heating – Gray The heating setpoint the controller maintains while in unoccupied mode.	D: 55 °F (12.7 °C) R: 40 to 90 °F (4.4 to 32.2 °C)
Unoccupied Cooling – Gray The cooling setpoint the controller maintains while in unoccupied mode.	D: 90 °F (32.2 °C) R: 45 to 99 °F (7.2 to 37.2 °C)
Unoccupied Heating 1 – Light Blue The space temperature must be less than the Unoccupied Heating 1 setpoint for the VVT Master to consider the zone an unoccupied heating caller in a linked system. In a single-zone application, the unoccupied heating requirement begins as soon as the space temperature falls below the Unoccupied Heating setpoint. We recommend that the Unoccupied Heating 1 value be set no less than 0.5Δ °F (.27Δ °C) below the Unoccupied Heating setpoint.	D: 54 °F (12.2 °C) R: 40 to 90 °F (4.4 to 32.2 °C)

Point Name/Description	Default/Range
<p>Unoccupied Heating 2 – Dark Blue</p> <p>The space temperature must be less than the Unoccupied Heating 2 setpoint to generate an unoccupied low space temperature alarm. We recommend that this value be set no less than $0.5\Delta^{\circ}\text{F}$ ($.27\Delta^{\circ}\text{C}$) below the Unoccupied Heating 1 setpoint.</p>	<p>D: 52°F (11.1°C)</p> <p>R: 40 to 90°F (4.4 to 32.2°C)</p>
<p>Unoccupied Cooling 1 – Yellow</p> <p>The space temperature must be greater than the Unoccupied Cooling 1 setpoint for the VVT Master to consider the zone an unoccupied cooling caller in a linked system. In a single-zone application, the unoccupied cooling requirement begins as soon as the space temperature exceeds the Unoccupied Cooling setpoint. We recommend that the Unoccupied Cooling 1 value be set no less than $0.5\Delta^{\circ}\text{F}$ ($.27\Delta^{\circ}\text{C}$) above the Unoccupied Cooling setpoint.</p>	<p>D: 91°F (32.7°C)</p> <p>R: 45 to 99°F (7.2 to 37.2°C)</p>
<p>Unoccupied Cooling 2 – Orange</p> <p>The space temperature must be greater than the Unoccupied Cooling 2 setpoint to generate an unoccupied high space temperature alarm. We recommend that this value be set no less than $0.5\Delta^{\circ}\text{F}$ ($.27\Delta^{\circ}\text{C}$) above the Unoccupied Cooling 1 setpoint.</p>	<p>D: 93°F (33.9°C)</p> <p>R: 45 to 99°F (7.2 to 37.2°C)</p>

Point Name/Description	Default/Range
<p>Heating Capacity – Used for Optimal Start, this is the rate at which the zone temperature changes when the heating system runs at full capacity to maintain designed occupied heating setpoint.</p>	<p>D: $3\Delta^{\circ}\text{F}$ ($1.6\Delta^{\circ}\text{C}$)/hr</p> <p>R: 0 to $120\Delta^{\circ}\text{F}$ (0 to $66.6\Delta^{\circ}\text{C}$)/hr</p>
<p>Heating Design Temp – The geographically-based outdoor air temperature at which the heating system must run constantly to maintain comfort. This information is available in ASHRAE publications and most design references.</p>	<p>D: 0°F/C</p> <p>R: -100 to 150°F (-73.3 to 65.5°C)</p>
<p>Cooling Capacity – Used for Optimal Start, this is the rate at which the zone temperature changes when cooling system runs at full capacity to maintain designed occupied cooling setpoint.</p>	<p>D: $3\Delta^{\circ}\text{F}$ ($1.6\Delta^{\circ}\text{C}$)/hr</p> <p>R: 0 to $140\Delta^{\circ}\text{F}$ (0 to $77.7\Delta^{\circ}\text{C}$)/hr</p>
<p>Cooling Design Temp – The geographically-based outdoor air temperature at which the cooling system must run constantly to maintain comfort. This information is available in ASHRAE publications and most design references.</p>	<p>D: 100°F (37.7°C)</p> <p>R: -100 to 150°F (-73.3 to 65.5°C)</p>

Hysteresis – The desired difference between the temperature at which the zone color changes as the zone temperature departs from the acceptable range between the heating and cooling setpoints (green) into the Cooling 1 (yellow) or Heating 1 (light blue) and the temperature at which the zone color changes back to the acceptable range between the heating and cooling setpoints.

D: $.5\Delta^{\circ}\text{F}$ ($.27\Delta^{\circ}\text{C}$)
 R: 0.2 to $1.0\Delta^{\circ}\text{F}$
 ($.1$ to $.5\Delta^{\circ}\text{C}$)

For example, the following graph shows the zone color that results as the zone temperature departs from and returns to the acceptable range in a zone with the following settings:

- Color Change Hysteresis = $.5\Delta^{\circ}\text{F}$ ($.27\Delta^{\circ}\text{C}$) (applies as the temperature returns to the acceptable range)
- Occupied cooling setpoint = 76°F (24.4°C)
- Occupied heating setpoint = 70°F (21.1°C)

NOTE The values in the graph below are Fahrenheit.

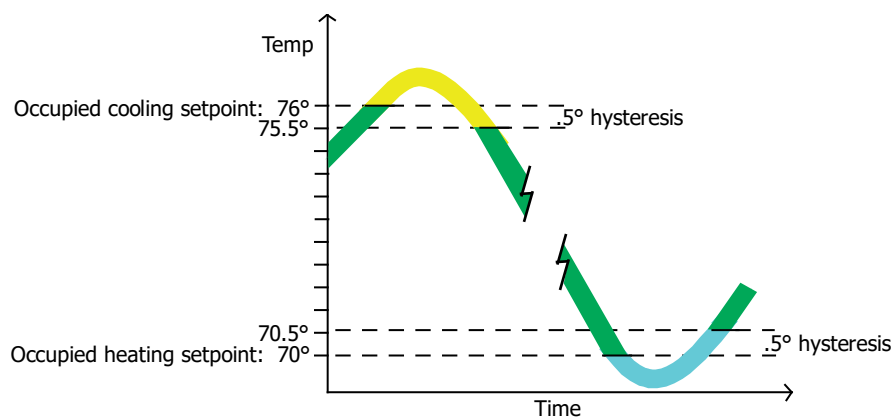

Learning Adaptive Optimal Start

Red	DkBlue	LtBlue	Green or SpGrn	Yellow	Orange	Red
0.1900	0.1300	0.0600	0.0600	0.0600	0.1300	0.1900

When the Learning Adaptive Optimal Start algorithm runs, the learned heating capacity or learned cooling capacity values are adjusted based on the color that is achieved when occupancy begins. The adjustment amounts for each color are displayed in the thermographic color fields (shown above with English default values).

Point Name/Description	Range	
	English	Metric
Red – The amount the zone’s learned heating capacity is adjusted when the Learning Adaptive Optimal Start algorithm runs, when the zone’s thermographic color at occupancy is red.	D: 0.1900 R: 0 to 1	.1055
DkBlue – The amount the zone’s learned heating capacity is adjusted when the Learning Adaptive Optimal Start algorithm runs, when the zone’s thermographic color at occupancy is dark blue.	D: 0.1300 R: 0 to 1	.0722
LtBlue – The amount the zone’s learned heating capacity is adjusted when the Learning Adaptive Optimal Start algorithm runs, when the zone’s thermographic color at occupancy is light blue.	D: 0.0600 R: 0 to 1	.0333

Point Name/Description	Range	
	English	Metric
Green – The amount the zone’s learned heating capacity is adjusted when the Learning Adaptive Optimal Start algorithm runs, when the zone’s thermographic color at occupancy is green.	D: 0.0600 R: 0 to 1	.0333
SpGrn – The amount the zone’s learned cooling capacity is adjusted when the Learning Adaptive Optimal Start algorithm runs, when the zone’s thermographic color at occupancy is green.	D: 0.0600 R: 0 to 1	.0333
Yellow – The amount the zone’s learned cooling capacity is adjusted when the Learning Adaptive Optimal Start algorithm runs, when the zone’s thermographic color at occupancy is yellow.	D: 0.0600 R: 0 to 1	.0333
Orange – The amount the zone’s learned cooling capacity is adjusted when the Learning Adaptive Optimal Start algorithm runs, when the zone’s thermographic color at occupancy is orange.	D: 0.1300 R: 0 to 1	.0722
Red – The amount the zone’s learned cooling capacity is adjusted when the Learning Adaptive Optimal Start algorithm runs, when the zone’s thermographic color at occupancy is red.	D: 0.1900 R: 0 to 1	.1055

Heating – (Occupied or Unoccupied, depending on mode) The current programmed Heating setpoint adjusted by any offset that may be in effect.	R: 0 to 120°F (-17.7 to 48.9°C)
Cooling – (Occupied or Unoccupied, depending on mode) The current programmed Cooling setpoint adjusted by any offset that may be in effect.	R: 0 to 120°F (-17.7 to 48.9°C)
Learned cooling capacity – The cooling capacity learned by Learning Adaptive Optimal Start that is required to bring the space temperature down to the occupied cooling setpoint prior to the occupied time.	R: _ °F/C
Learned heating capacity – The heating capacity learned by Learning Adaptive Optimal Start that is required to bring the space temperature up to the occupied heating setpoint prior to the occupied time.	R: _ °F/C
Optimal Start – The number of hours prior to occupancy, at which the Optimal Start function may begin to adjust the effective setpoints to achieve the occupied setpoints by the time scheduled occupancy begins. Enter 0 to disable Optimal Start. NOTE Optimal Start is automatically disabled when Properties > Control Program > Maintenance > Occupancy > BAS On/Off is set to either Unoccupied or Occupied .	D: 1 hr R: 0 to 4 hrs
Optimal Start Type – The method used to change from unoccupied to occupied setpoint. Options: None* – Unit will not change to occupied setpoint until the scheduled time or the unit goes into an occupied mode. Setpoints do not ramp, but change immediately from unoccupied to occupied values. Temp Compensated* – Unit changes to occupied setpoints at a variable time prior to the occupied time, which is calculated by the current difference between space temperature and the appropriate heating or cooling setpoint. At that time, the setpoints do not ramp, but change immediately from unoccupied to occupied values. Learning Adaptive Start – Unit gradually changes to occupied setpoints by adjusting the unoccupied setpoints over a specified period of time to achieve the occupied setpoint by the time scheduled occupancy begins.	D: Temperature Compensated None R: Temperature Compensated Learning Adaptive

<p>Heat Start K factor (min/deg) – If Optimal Start Type is Temp Compensated, this is the time in minutes per degree that the equipment starts before the occupied period when the space temperature is below the occupied heating setpoint (including any setpoint offset).</p>	<p>D: 15.00 R: 0 to 99</p>
<p>Cool Start K factor (min/deg) – If Optimal Start Type is Temp Compensated, this is the time in minutes per degree that the equipment starts before the occupied period when the space temperature is above the occupied cooling setpoint (including any setpoint offset).</p>	<p>D: 15.00 R: 0 to 99</p>
<p>Standby Offset – The value by which the occupied setpoints are expanded when the space occupancy sensor indicates that the space is unoccupied. If 0, the unoccupied setpoints are used.</p>	<p>D: 0Δ°F/Δ°C R: 0 to 15Δ°F (0 to 8.3Δ°C)</p>
<p>Occupied RH Control Setpoint – If Optional Sensor Type is set to RH Sensor and RH Control is set to Enable, this is the relative humidity setpoint during occupancy. The air source mode must be Cool or Vent and the terminal mode must be Cooling or Vent before the dehumidification function can be active.</p>	<p>D: 65%rh R: 0 to 100%rh</p>
<p>DCV Start Ctrl Setpoint – If Optional Sensor Type is set to IAQ Sensor and DCV Control is set to Enable, this is the value that the CO2 sensor must exceed to begin the DCV control function. This value should be set to approximately 75 ppm above the outdoor air CO2 level.</p>	<p>D: 500ppm R: 0 to 9999 ppm</p>
<p>DCV Max Ctrl Setpoint – If Optional Sensor Type is set to IAQ Sensor and DCV Control is set to Enable, this is the value that the CO2 level must exceed to begin the IAQ function to control the damper to DCV MAX Vent Airflow.</p>	<p>D: 1050ppm R: 0 to 9999 ppm</p>
<p>Parallel Fan ON Value – If Terminal Type is Parallel Fan and the zone does not require heating, when the zone’s airflow control setpoint decreases below this value, the parallel fan turns on to increase airflow, ventilation, and prevent cold air dumping into the zone. If the airflow control setpoint rises above this value by more than 1 cfm (liters/sec), the parallel fan turns off. We recommend this value be set to approximately 10% above the Occupied Min Airflow setpoint. Set to 0 to disable this function.</p>	<p>D: 0 cfm (liters/sec) R: 0 to 99999 cfm (liters/second)</p>

Setpoints for ZS Sensors

To configure setpoint properties for ZS sensors, CTRL+click anywhere on the **Zone Setpoints**: graph at the top of the **Setpoints** section in order to access the **Properties** popup.

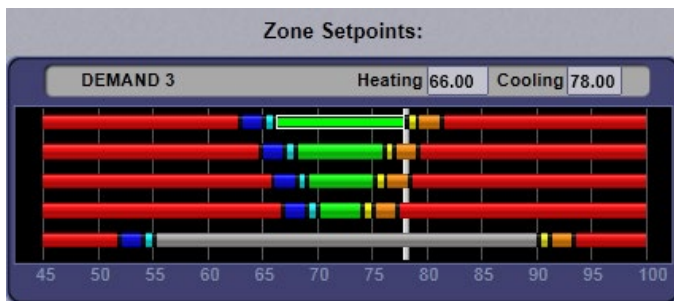

In the popup, select the **Properties** > **Sensor** tab to configure ZS sensors for **Setpoint Adjust**.

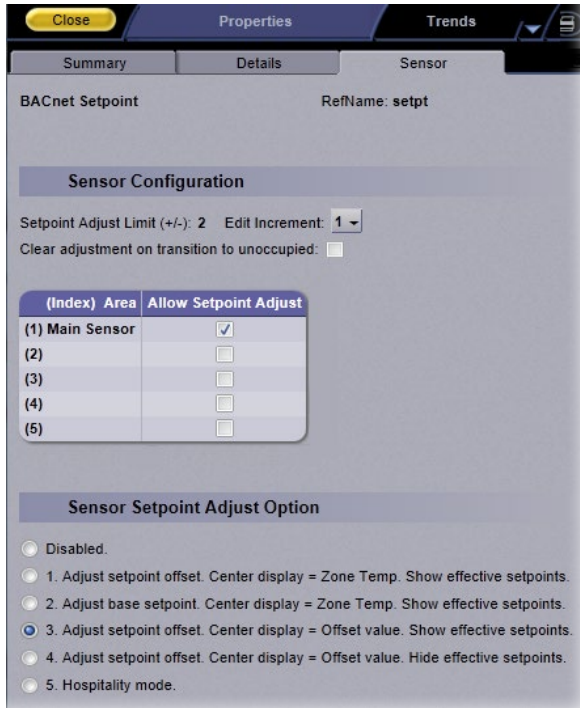

Edit Increment – Amount of offset in degrees for each press of the up or down arrows on the ZS Sensor for setpoint adjustment.

D: 1
R: 0.1
0.5
1

Allow Setpoint Adjustment – Check to allow setpoint adjustments on the specified ZS sensor.

D: (1) enabled
R: disabled/enabled

Sensor Setpoint Adjust Option – Check to select the ZS setpoint adjustment display.

D: 3

Alarm Configuration

Navigation: i-Vu® / Field Assistant: **Properties > Control Program > Configuration > Alarm Configuration**

Point Name/Description	Default/Range
Space Temperature Alarm	
Occupied Alarm Hysteresis – This value is added to the effective cooling setpoints and subtracted from the effective heating setpoints as output from the Setpoint microblock. These values establish the occupied high and low limits that the space temperature must exceed before an occupied SPT alarm is generated. The alarm returns to normal when the space temperature drops below the high effective setpoint or rises above the low effective setpoint.	D: 5Δ °F (2.7Δ °C) R: 0 to 20Δ °F (0 to 11.1Δ °C)
Alarm Delay (min/deg) – Determines the amount of delay before an occupied space temperature alarm is generated when the controller transitions to the occupied mode. The delay time equals this value multiplied by the difference between the sensor temperature and occupied alarm setpoint plus 15 minutes.	D: 10 minutes R: 0 to 30 minutes
Unoccupied Low SPT Alarm Limit –The value that the space temperature must drop below to generate a Space Temperature Alarm in the unoccupied mode. There is a fixed hysteresis of 1Δ °F (.5Δ °C) for return to normal.	D: 45 °F (7.2 °C) R: 35 to 90 °F (1.6 to 32.2 °C)
Unoccupied High SPT Alarm Limit – The value that the space temperature must exceed to generate a Space Temperature Alarm in the unoccupied mode. There is a fixed hysteresis of 1Δ °F (.5Δ °C) for return to normal.	D: 95 °F (35 °C) R: 45 to 100 °F (7.2 to 37.7 °C)
Supply Air Temperature Alarm	
Low SAT Alarm Limit – The value that the supply air temperature must drop below to generate a Supply Air Temp Alarm . There is a fixed hysteresis of 3Δ °F (1.6Δ °C) for return to normal.	D: 45 °F (7.2 °C) R: 15 to 90 °F (-9.4 to 32.2 °C)
High SAT Alarm Limit – The value that the supply air temperature must exceed to generate a Supply Air Temp Alarm . There is a fixed hysteresis of 3Δ °F (1.6Δ °C) for return to normal. This should be set at least 15Δ °F (8.3Δ °C) higher than the Maximum Heating SAT .	D: 120 °F (48.9 °C) R: 90 to 175 °F (32.2 to 79.4 °C)
Space Humidity Alarm	
Occupied High RH Alarm Limit – The value that the relative humidity sensor must exceed to generate a Space Humidity Alarm in the occupied mode if RH Control is set to Enable . There is a fixed hysteresis of 5%rh for return to normal.	D: 100%rh R: 45 to 100%rh
Alarm Delay (min/%RH) – Determines the amount of delay before an occupied RH alarm is generated when the controller transitions to the occupied mode. The delay time equals this value multiplied by the difference between the sensor RH value and the occupied RH setpoint plus 15 minutes.	D: 5 minutes R: 0 to 30 minutes
Unocc High RH Alarm Limit – The value that the relative humidity sensor must exceed to generate a Space Humidity Alarm in the unoccupied mode if RH Control is set to Enable . There is a fixed hysteresis of 5%rh for return to normal.	D: 100%rh R: 45 to 100%rh

Point Name/Description	Default/Range
IAQ/Ventilation Alarm	
Occupied High CO2 Alarm Limit – The value that the CO ₂ sensor must exceed to generate an Indoor Air Quality Alarm in the occupied mode if DCV Control is set to Enable . There is a fixed hysteresis of 100ppm for return to normal.	D: 1100ppm R: 0 to 9999 ppm
Alarm Delay (min/ppm) – The fractional portion of a minute used to determine the amount of delay before an indoor air quality alarm is generated when the controller transitions to the occupied mode. The delay time equals this value multiplied by the difference between the sensor CO ₂ value and the setpoint plus 15 minutes.	D: 0.25 minutes R: 0.10 to 1.00 minutes
Alarms Displayed on ZS or SPT Sensor	
Space Temperature Alarm – If set to display, shows the alarm indicator on the communicating zone sensors, if the Space Temperature alarm is active.	D: Ignore R: Ignore/Display
Supply Air Temp Alarm – If set to display, shows the alarm indicator on the communicating zone sensors, if the Supply Air Temp alarm is active.	D: Ignore R: Ignore/Display
Dirty Filter Alarm – If set to display, shows the alarm indicator on the communicating zone sensors, if a Filter alarm is active.	D: Display R: Ignore/Display
Space High Humidity Alarm – If set to display, shows the alarm indicator on the communicating zone sensors with display, if the Space Relative Humidity alarm is active.	D: Ignore R: Ignore/Display
Space High CO2 Alarm – If set to display, shows the alarm indicator on the communicating zone sensors with display if the Indoor Air Quality Alarm is in alarm.	D: Ignore R: Ignore/Display
Maintenance Displayed on ZS Sensor	
Linkage Fault – If set to display, shows the maintenance indicator on the ZS Pro sensor if the Airside Linkage is in a Fault condition.	D: Ignore R: Ignore/Display
Net OAT Fault – If set to display, shows the maintenance indicator on the ZS Pro sensor if the Network Outside Air is not valid.	D: Ignore R: Ignore/Display
SPT Sensor Fault – If set to display, shows the maintenance indicator on the ZS Pro sensor if the space temperature sensor is not valid.	D: Ignore R: Ignore/Display

Service Configuration

Navigation: i-Vu® / Field Assistant: **Properties > Control Program > Configuration > Service Configuration**

Point Name/Description	Default/Range
Terminal Type – The type of zone terminal that the controller is installed on. Not available for VAVB1.	D: Single Duct R: Single Duct Parallel Series Fan
Terminal Size – Shows the value entered as the Cooling Max Airflow in the Flow Control object.	D: 2100 cfm (991.2 liters/second) R: 0 to 99999 cfm (liters/second)
Terminal Fan Airflow – Enter the terminal fan airflow in cfm (liters/second). Used in performance calculations only. Available only on fan-enabled terminal box.	D: 1000 cfm (472 liters/second) R: 0 to 99999 cfm (liters/second)
Disable Series Fan – When set to Enable , the controller disables the fan on a series-type terminal when the airflow setpoint equals 0. (We do not recommend configuring the minimum occupied airflow setpoint to 0, as this does not meet minimum ventilation requirements.)	D: N/A R: N/A Enable
External Actuator Enable – Enable if the controller's analog output is used for an external high-torque or slave actuator. Enabling this setting disables the output for Modulating Hot Water or Combination reheat functions.	D: Disable R: Disable/Enable
Heat Type – The type of supplemental reheat that the zone controller will control. The heat may be used with system heat, depending on the space temperature demand. Options: None – no heat Modulating – ducted or baseboard modulating hot water Two Position – two position hot water Staged EH – ducted or baseboard electric heat Combination – combination baseboard modulating hot water and ducted staged electric heat CV Modulating – constant volume modulating reheat used for single duct terminal application with modulating hot water reheat (typically used in hospital applications) SCR Electric – modulating control for SCR-type electric heater	D: None R: None Modulating Two Position Staged EH Combination CV Modulating SCR Electric
Ducted Heat – Determines whether the zone is using ducted heat or baseboard. If Heat Type is Combination , set this field to Yes for ducted heat.	D: Yes R: No/Yes
VAV Reheat – If set to Enable and Heat Type is Modulating , a need for heat first modulates the supply air temperature up to the configured Maximum Heating SAT (95°F [35 °C] default). A further heating demand will increase the airflow from the minimum rate up to the configured Auxiliary Heat Min Airflow . Applicable to single duct terminals only.	D: Enable R: Disable/Enable

Point Name/Description	Default/Range
<p>CV Modulating PID – This BACnet object calculates the amount of capacity required to satisfy the current space temperature setpoint, when the terminal is heating and the Heat Type is set to CV Modulating.</p> <p>CAUTION The default values should be changed only by a technician trained in PID Loop algorithms.</p>	D: Type = reverse Update Interval = 0:15 P = 20 (40 metric) I = 1.0 (2.0 metric) D = 0 Bias = 0 Deadband = 0
<p>VAV Heating – Set to Enable to have the terminal modulate its airflow to meet a zone heating demand when the air source mode is Heating or Warm-up. Always set to Disable for parallel fan terminals.</p>	D: Disable R: Disable/Enable
<p>Number of Heat Stages – The number heat stages when the Heat Type is Staged EH. Fan-powered terminals are limited to no more than 2 stages.</p>	D: Two stages R: One stage Two stages Three stages
<p>Valve Type – Two Position hot water only - The hot water valve's position with no power applied to the valve.</p>	D: NC R: NC/NO (normally closed/normally open)
<p>Hardwired Sensor – The type of sensor used on the controller's RH/CO2 hardwire input. This setting determines the control channel input function.</p> <p>Options: RH Sensor – Relative humidity for zone dehumidification IAQ Sensor – Indoor air quality for DCV control</p> <p>NOTE RH and IAQ are also available with communicating ZS RH and CO₂ sensors.</p>	D: None R: None RH Sensor IAQ Sensor
<p>RH Control – Enables or disables zone dehumidification control if valid RH sensor values are available.</p>	D: Disable R: Disable/Enable
<p>DCV Control – Enables or disables demand control ventilation control.</p>	D: Disable R: Disable/Enable
<p>Min Setpoint Separation – Minimum separation that must be maintained between the heating and cooling setpoints.</p>	D: 4Δ °F (2.2Δ °C) R: 2 to 10Δ °F (1.1 to 5.5Δ °C)
<p>Occ Override Normal Logic State – The normal state of the controller's Remote Occupancy input. If the input's contact is the same state as the configured state, the controller follows its controlling schedule. If the contact is in the opposite state of the configured state, the controller is forced into the unoccupied mode.</p>	D: Open R: Open/Closed
<p>RH Sensor Min Input Volts – The lowest voltage that should be read from the hardwired relative humidity (RH) sensor.</p>	D: 0.00 V R: 0 to 5.00 V
<p>RH Sensor Max Input Volts – The highest voltage that should be read from the hardwired RH sensor.</p>	D: 5.00 V R: 0 to 5.00 V
<p>RH Sensor Value @ Min Volts – The % relative humidity that correlates to the hardwired RH sensor's low voltage reading.</p>	D: 0% R: 0 to 99%

Point Name/Description	Default/Range
RH Sensor Value @ Max Volts – The % relative humidity that correlates to the hardwired RH sensor's high voltage reading.	D: 100% R: 0 to 100%
CO2 Sensor Min Input Volts – The lowest voltage that should be read from the hardwired CO ₂ sensor.	D: 1.00 V R: 0 to 5.00 V
CO2 Sensor Max Input Volts – The highest voltage that should be read from the hardwired CO ₂ sensor.	D: 5.00 V R: 0 to 5.00 V
CO2 Sensor Value @ Min Volts – The ppm value that correlates to the hardwired CO ₂ sensor's low voltage reading.	D: 0 ppm R: 0 to 9999 ppm
CO2 Sensor Value @ Max Volts – The ppm value that correlates to the hardwired CO ₂ sensor's high voltage reading.	D: 2000 ppm R: 0 to 9999 ppm
<p>Min% Heat airflow when AHU Heating - Increases the airflow to the zone and overrides the configured minimum airflow value whenever the air source is in a heating mode. If set to 0%, no override is active and the Occupied or Unoccupied Min Airflow value is used.</p> <p>This is not a direct percentage of the Max Heat cfm.</p> <p>To calculate the Min% Heat airflow when AHU Heating configuration, when based on the Heating Max cfm, Occ Min, and the desired heat minimum airflow cfm, use the formula Min% Heat airflow when AHU Heating = (Heat Min – Occ Min) / (Heat Max – Occ Min).</p> <p>Variables:</p> <ul style="list-style-type: none"> • Heat Min = Desired Heating Minimum cfm when AHU Heating • Heat Max = Heating Maximum cfm • Occ Min = Occupied Minimum cfm • Min% Heat airflow when AHU Heating = configuration value in % to achieve min airflow in AHU heat mode <p>NOTE These formulas do not generate an exact Heat Min cfm value, but will generate a value that should maintain the desired Heat Minimum Airflow, whenever the AHU is in a Heating Mode. To disable any increase in airflow during AHU Heating, set the Heat Min value to 0%.</p> <p>To calculate the minimum heating cfm when the AHU mode is Heat, use the formula below to get the resulting Min Heat cfm when in the occupied mode:</p> <p>Heat Min = [Min% Heat airflow when AHU Heating * (Heat Max - Occ Min)] + Occ Min</p>	D: 0% R: 0 to 100%
<p>Flow Control: Click Flow Control to access the microblock popup Properties page > Summary and Details tabs. See the microblock Help for more detailed explanations.</p>	
Flow sensor - The airflow sensor type used by your equipment. Leave as Built-in flow sensor .	D: Built-in flow sensor
Damper Actuator - The damper type used by the equipment. Leave as Built-in actuator .	D: Built-in actuator

Point Name/Description	Default/Range
Flow Measurement Units – The flow measurement output. Do not change the default of cfm (liters/second).	D: cfm (liters/second)
Damper Motor Travel Time – The actuator's travel time from full closed to full open. Leave this field at 205 seconds.	D: 205 seconds
Direction Clockwise – If Damper Actuator is set to Built-in actuator , set this field to the damper's position when it rotates clockwise.	D: Open R: Close/Open
Target Damper Position - The current damper position. To override normal control for troubleshooting purposes, select Lock value to and then enter a value. The damper moves to that position until Lock value to checkbox is cleared.	R: 0 to 100%
Auxheat - The current configured Reheat Min Damper Position . To override normal control for reheat troubleshooting purposes, select Lock value to and then enter a value. The damper moves to that position until Lock value to checkbox is cleared.	R: 0 to 100%
Fan – The current value of the fan output relay. To override normal control for troubleshooting purposes, select Lock value to and then enter On or Off . The relay stays in that state until the Lock value to checkbox is cleared.	R: Off/On
Cooling Max Airflow – The maximum airflow the terminal will supply when trying to meet a zone cooling demand when the air source mode is Cooling, Vent, or Free Cooling.	D: 2100 cfm (991.2 liters/second) R: 0 to 99999 cfm (liters/second)
Heating Max Airflow – The maximum airflow the terminal will supply when trying to meet a zone heating demand when the air source mode is Heating or Warm-up and VAV heating has been enabled.	D: 2100 cfm (991.2 liters/second) R: 0 to 99999 cfm (liters/second)
Occupied Min Airflow – The minimum airflow setpoint the terminal controls to when the air source is operating and the terminal mode is occupied.	D: 315 cfm (148.9 liters/second) R: 0 to 99999 cfm (liters/second)
Unoccupied Min Airflow – The minimum airflow setpoint the terminal controls to when the air source is operating and the terminal mode is unoccupied.	D: 315 cfm (148.9 liters/second) R: 0 to 99999 cfm (liters/second)
Auxiliary Heat Min Airflow – ONLY used for Single Duct units with ducted reheat. Set to the minimum airflow specified by the manufacturer to allow the reheat to provide optimum performance. This value is compared to the appropriate Min Airflow value above and the greater of the two values determines the damper position. For all other terminal types, set to 0.	D: 1680 cfm (793 liters/second) R: 0 to 99999 cfm (liters/second)
Manufacturer's specified airflow at 1" water column – The damper manufacturer's rated cfm airflow at 1" water column of velocity pressure. Refer to the manufacturer's documentation to obtain the correct value.	D: 2100 cfm (991.2 liters/second) R: 0 to 99999 cfm (liters/second)
Use supply air for heating when Heat Mode is ON – This must be checked for all applications. To only use the minimum airflow in heating, set Service Configuration > VAV Heating to Disable .	D: Checked R: Checked/Unchecked

Point Name/Description	Default/Range
<p>Test and Balance – Use the following command buttons when commissioning a zone, balancing the system, replacing the zone controller, or troubleshooting. If Automatic Control is not selected within 4 hours, the controller will resume normal control.</p> <p>Zero Flow – Closes the damper, takes a number of flow samples, then sets the zero calibration.</p> <p>Damper Full Open – Opens damper fully and enables the Damper Full Open calibration fields.</p> <p>Cool Max Airflow – Forces the damper to its maximum cooling position. Calibration fields apply only if the primary use of this damper is cooling.</p> <p>Occupied Min Airflow – Forces the damper to its maximum cooling position. Calibration fields apply only if the primary use of this damper is cooling.</p> <p>Automatic Control – Returns the damper to its normal control routines. This must be activated when you finish using any of the other Test and Balance commands.</p> <p>Close Damper – Forces the damper to its full closed position.</p> <p>Heat Max Airflow – Forces the damper to its maximum heating position. Calibration fields apply only if the primary use of the damper is heating.</p>	

<p>Sensor Binder / Zone Temp / Zone Humidity / ZS Zone CO2</p> <p>Ctrl+click on the name of these properties to access the microblock popup Properties page > Details tab. See below for instructions on configuring your ZS or wireless sensors. See the microblock Help for more detailed explanations.</p>																																																		
<p>Sensor Binder - Use the Associated Sensors table to configure the Rnet to use additional ZS or wireless sensors.</p> <table border="1"> <thead> <tr> <th>Index</th> <th>Area</th> <th>Network Type</th> <th>Address</th> <th>Lock Display</th> <th>Version</th> <th>Status</th> <th>Error</th> </tr> </thead> <tbody> <tr> <td>1</td> <td>Main Sensor</td> <td>Rnet ▼</td> <td>1</td> <td><input type="checkbox"/></td> <td></td> <td>Sensor Offline</td> <td>No Comm</td> </tr> <tr> <td>2</td> <td>Sensor 2</td> <td>Unused ▼</td> <td>2</td> <td><input type="checkbox"/></td> <td></td> <td>Sensor Offline</td> <td>None</td> </tr> <tr> <td>3</td> <td>Sensor 3</td> <td>Unused ▼</td> <td>3</td> <td><input type="checkbox"/></td> <td></td> <td>Sensor Offline</td> <td>None</td> </tr> <tr> <td>4</td> <td>Sensor 4</td> <td>Unused ▼</td> <td>4</td> <td><input type="checkbox"/></td> <td></td> <td>Sensor Offline</td> <td>None</td> </tr> <tr> <td>5</td> <td>Sensor 5</td> <td>Unused ▼</td> <td>5</td> <td><input type="checkbox"/></td> <td></td> <td>Sensor Offline</td> <td>None</td> </tr> </tbody> </table> <ul style="list-style-type: none"> • Network Type - Set to Rnet • Address - Enter the DIP switch settings that are on the additional ZS sensors (up to 5 total) or RnetID assigned to each wireless sensor in SensorBuilder • Lock Display - Check to make the sensor display-only 		Index	Area	Network Type	Address	Lock Display	Version	Status	Error	1	Main Sensor	Rnet ▼	1	<input type="checkbox"/>		Sensor Offline	No Comm	2	Sensor 2	Unused ▼	2	<input type="checkbox"/>		Sensor Offline	None	3	Sensor 3	Unused ▼	3	<input type="checkbox"/>		Sensor Offline	None	4	Sensor 4	Unused ▼	4	<input type="checkbox"/>		Sensor Offline	None	5	Sensor 5	Unused ▼	5	<input type="checkbox"/>		Sensor Offline	None	<p>D: (Index) - (1)</p> <p>Network Type - Rnet</p> <p>Address - 1</p>
Index	Area	Network Type	Address	Lock Display	Version	Status	Error																																											
1	Main Sensor	Rnet ▼	1	<input type="checkbox"/>		Sensor Offline	No Comm																																											
2	Sensor 2	Unused ▼	2	<input type="checkbox"/>		Sensor Offline	None																																											
3	Sensor 3	Unused ▼	3	<input type="checkbox"/>		Sensor Offline	None																																											
4	Sensor 4	Unused ▼	4	<input type="checkbox"/>		Sensor Offline	None																																											
5	Sensor 5	Unused ▼	5	<input type="checkbox"/>		Sensor Offline	None																																											

Zone Temp - Configure additional ZS or wireless temperature sensors used on the VAV Zone II.

Sensor Configuration					
Rnet Tag: Zone Temp (1)					
(Index) Area	Use	Raw Value	Calibration	Corrected Value	Status
(1) Main Sensor	<input checked="" type="checkbox"/>	74.35294	0	74.352	None
(2)	<input type="checkbox"/>	0	0	-999.000	No Comm
(3)	<input type="checkbox"/>	0	0	-999.000	No Comm
(4)	<input type="checkbox"/>	0	0	-999.000	No Comm
(5)	<input type="checkbox"/>	0	0	-999.000	No Comm

Combination Algorithm: **Average** Input Smoothing: **None**

- **Use** - Check to include ZS or wireless sensors' value in the **Combined Algorithm** (**Average** is the default).
- **Raw Value** - Displays sensed temperature for each ZS or wireless temperature sensor's address
- **Calibration** - If needed, enter value to adjust the **Corrected Value** from the **Raw Value**, in order to calibrate an individual ZS or wireless sensor's sensed value.
- **Combination Algorithm** - Use **Average**, **Maximum**, or **Minimum** zone temperature to calculate the **Corrected Value** for temperature control.

D: **(Index) Area** - (1) Main Sensor
Use - checked
Calibration - 0
Combination Algorithm - Average
Input Smoothing - None
Show on Sensors - Calculated Value
Display Resolution - 1
COV Increment - .1

Zone Humidity - Configure additional ZS or wireless humidity sensors used on the VAV Zone II.

Sensor Configuration					
Rnet Tag: Zone Humidity (2)					
(Index) Area	Use	Raw Value	Calibration	Corrected Value	Status
(1) Main Sensor	<input type="checkbox"/>	32.772625	0	32.772	None
(2)	<input type="checkbox"/>	0	0	-999.000	No Comm
(3)	<input type="checkbox"/>	0	0	-999.000	No Comm
(4)	<input type="checkbox"/>	0	0	-999.000	No Comm
(5)	<input type="checkbox"/>	0	0	-999.000	No Comm

Combination Algorithm: **Maximum** Input Smoothing: **Medium**

- **Use** - Check to include ZS or wireless sensors' value in the **Combined Algorithm** (**Maximum** is the default).
- **Raw Value** - Displays sensed humidity for each ZS or wireless humidity sensor's address
- **Calibration** - If needed, enter value to adjust the **Corrected Value** from the **Raw Value**, in order to calibrate an individual ZS or wireless sensor's sensed value.
- **Combination Algorithm** - Use **Average**, **Maximum**, or **Minimum** ZS or wireless humidity to calculate the **Corrected Value** for humidity control.

D: **(Index) Area** - (1) Main Sensor
Use - unchecked
Calibration - 0
Combination Algorithm - Maximum
Input Smoothing - None
Show on Sensors - Calculated Value
Display Resolution - 1
COV Increment - 1

ZS Zone CO2 - Configure additional ZS CO₂ sensors used on the VAV Zone II.

(Index)	Area	Use	Raw Value	Calibration	Corrected Value	Status
(1)	Main ZS Sensor	<input type="checkbox"/>	0	0	-999.000	Unsupported Read
(2)		<input type="checkbox"/>	0	0	-999.000	No Comm
(3)		<input type="checkbox"/>	0	0	-999.000	No Comm
(4)		<input type="checkbox"/>	0	0	-999.000	No Comm
(5)		<input type="checkbox"/>	0	0	-999.000	No Comm

Combination Algorithm: **Maximum** Input Smoothing: **Medium**

- **Use** - Check to include ZS sensors' value in the **Combined Algorithm** (**Maximum** is the default).
- **Raw Value** -Displays sensed CO₂ for each ZS CO₂ sensor's address
- **Calibration** - If needed, enter value to adjust the **Corrected Value** from the **Raw Value**, in order to calibrate an individual ZS sensor's sensed value.
- **Combination Algorithm** - Use **Average**, **Maximum**, or **Minimum** ZS CO₂ to calculate the **Corrected Value** for CO₂ control.

D: **(Index) Area** - (1) Main ZS Sensor
Use - unchecked
Calibration - 0
Combination Algorithm - Maximum
Input Smoothing - Medium
Show on Sensors - Calculated Value
Display Resolution - 1
COV Increment - 10

WS Battery Strength % — Displays charge strength indicated on the wireless space temperature sensor. If there are multiple wireless sensors, it displays the lowest value.	R: _%
WS Signal Strength % — Displays radio signal strength of the wireless space temperature sensor. If there are multiple wireless sensors, it displays the lowest value.	R: _%
Rnet Sensed Occupancy – Displays occupancy status detected by wireless infrared motion sensor.	R: Off/On
ZS model to show on graphic – Select the ZS model, from the drop-down list, that you want to display on the graphic.	D: ZS Pro model R: None ZS Pro model ZS Base model ZS Plus model
WS model to show on graphic – Select the wireless model, from the drop-down list, that you want to display on the graphic.	D: WS Plus model R: WS Base model WS Plus model WS Pro model
Net Space Temp to show on graphic — Select the type of sensor to display on graphic.	D: Equipment Touch R: Network Temp Equipment Touch
System Space Temperature – The current value of the controlling space temperature received over the network from another source. -999 indicates no value has been received and it will not be used.	R: -50 to 150 °F (-45.5 to 65.5 °C)
System Setpoint Adjustment – The space temperature setpoint adjustment value received over the network.	R: -5 to 5Δ °F (-2.7 to 2.7Δ °C)

System Space RH – The relative humidity received over the network. -999 indicates no value has been received and it will not be used.	R: 2 to 100%
System Space AQ – The indoor air quality received over the network. -999 indicates no value has been received and it will not be used.	R: 300 to 9999 ppm
System Cool Demand Level – The value received over the network and used by the demand limiting function to expand the cooling setpoint.	R: 0 to 3
System Heat Demand Level – The value received over the network and used by the demand limiting function to expand the heating setpoint.	R: 0 to 3
System Outdoor Air Temperature – The OAT received over the network.	R: -50 to 150° F (-45.5 to 65.5° C)
System Occupancy – The status of the System Occupancy network point.	D: Unoccupied R: Unoccupied/Occupied

Maintenance

Navigation: i-Vu® / Field Assistant: **Properties > Control Program > Maintenance**

Point Name/Description	Default/Range
Unit	
Occupancy Status – The controller's occupancy status as determined by a network schedule, a local schedule, or a timed override.	R: Unoccupied/Occupied
Temp Compensated Start or Learning Adaptive Start – Indicates the type of optimal start (if any) that is configured and whether the algorithm is active or inactive.	R: Inactive/Active
Space Temp Source – The source of the controlling space temperature value. Options: Sensor Failure – No valid space temperature or sensor status = failed. SPT Sensor – An SPT sensor is connected to the controller's Rnet port. T55/56 – A T55, T56, or T59 sensor is connected to the controller's I/O terminals. Network – A network temperature sensor is bound to the controller's space temperature AV. Airside Linkage – The space temperature from a linked terminal. Locked Value – The controller's space temperature input has been manually locked at a value. ZS Sensor – A ZS sensor is connected to the controller's Rnet port.	R: Sensor Failure SPT Sensor T55/T56 Network Airside Linkage Locked Value ZS Sensor
Setpoint Adjustment – The amount that a user has adjusted the setpoints at a zone sensor.	R: -20 to 20Δ° F (-11.1 to 11.1Δ° C)
Effective Heat Setpoint – The current heating setpoint. May include offsets from configured occupied/unoccupied setpoints resulting from Optimal Start to Demand Limit .	R: _ ° F/C

Point Name/Description	Default/Range
Effective Cool Setpoint – The current cooling setpoint. May include offsets from configured occupied/unoccupied setpoints resulting from Optimal Start to Demand Limit .	R: _ °F/C
VAV Reheat Status – Provides the status of the VAV Reheat function. This status automatically disables if the Terminal Type or Heat Type is unsuitable or if the VAV Reheat function is set to Disable .	R: Disabled/Enabled
Primary Airflow Setpoint – The desired airflow setpoint calculated by the controller to meet the required temperature, IAQ, or dehumidification requirements.	R: 0 to 99999 cfm (liters/second)
Relative Humidity Source – The source of the relative humidity value.	R: N/A Local Network Linkage Locked Value ZS Sensor
IAQ Source – The source of the indoor air quality value.	R: N/A Local Network Linkage Locked Value ZS Sensor
Outdoor Air Temperature Source – The source of the outdoor air temperature.	R: N/A Local Network Linkage Locked Value
Cooling Demand Level – The system cool demand level received over the network.	R: 0 to 3
Heating Demand Level – The system heat demand level received over the network.	R: 0 to 3
Heat Delay – The status of the terminal heat delay.	R: Inactive/Active
Remaining Heat Delay – If Heat Delay is Active , this is the remaining delay time.	R: 0 to 60 minutes
Calculated DCV Capacity – If DCV Control is set to Enable , this is the calculated minimum airflow, expressed as a percentage, that will be maintained to satisfy the ventilation requirement.	R: 0 to 100%
Calculated Dehumidify Capacity – If RH Control is set to Enable , this is the calculated minimum airflow, expressed as a percentage, that will be maintained to satisfy the dehumidification requirement.	R: 0 to 100%
Reset Filter Alarm – Set this to On to reset an active Filter Alarm and restart the Filter Service Alarm Timer . After the alarm returns to normal, this automatically changes to Off .	D: Off R: Off/On
Occupancy Contact State - The physical state of the Remote input.	R: Open/Closed
Cooling BTU's – Current Cooling Energy being delivered to the space.	R: 0 to 99999 BTU (0 to 99999 KJoules)
Heating BTU's – Current Heating Energy being delivered to the space.	R: 0 to 99999 BTU (0 to 99999 KJoules)
Occupancy	

Point Name/Description	Default/Range
<p>BAS On/Off – Determines the occupancy state of the controller and can be set over the network by another device or third party BAS.</p> <p>Options:</p> <p>Inactive – Occupancy is determined by a configured schedule. Occupied – The controller is always in the occupied mode. Unoccupied – The controller is always in the unoccupied mode.</p> <p>NOTE If BAS On/Off is set to either Unoccupied or Occupied, the Optimal Start routine is automatically disabled.</p>	<p>D: Inactive</p> <p>R: Inactive Occupied Unoccupied</p>
Schedules – The controller's occupancy status based on the local schedule.	R: Unoccupied/Occupied
Pushbutton Override – Active indicates if a user pushed the sensor's override button to override the occupancy state.	R: Off/Active
Override Time Remaining – The amount of time remaining in an override period.	R: 0 to 480 minutes
Occupancy Contact Status – The physical state of the controller's Remote input.	R: Inactive Inactive Active Unoccupied/Stdby
Global Occupancy – The System Occupancy network input's current state.	D: Unoccupied R: Unoccupied/Occupied

Local BACnet Schedule	R: Off/On
<p>Configure ZS Sensors by setting the following options in the Local BACnet Schedule microblock popup. Click Local BACnet Schedule to access the microblock popup Properties page > Details tab.</p> <p>See the microblock Help for more detailed explanations.</p>	
Sensor Configuration	
<p>Allow Force Unoccupied: – Check to allow a user to save energy by forcing the zone into an unoccupied schedule on the ZS sensor. The user does this by holding the sensor's On/Off button for at least 3 seconds. This forced state remains in effect until the schedule transitions to unoccupied or until a user presses the sensor's On/Off button again.</p>	<p>D: Enabled</p> <p>R: Disabled/Enabled</p>
<p>Force Unoccupied without Delay: – Check to allow a user to force a zone to unoccupied immediately instead of the normal 3-second delay.</p> <p>NOTE This option is not available if Allow TLO Set During Occupied is checked.</p>	<p>D: Enabled</p> <p>R: Disabled/Enabled</p>
Timed Local Override	
<p>Increment: – Minutes that the microblock adds to the zone's occupied time for each click of the zone's local override button or switch.</p>	D: 30:00 mm:ss
<p>Maximum Duration: – Maximum value (up to 960 minutes) the microblock outputs, regardless of additional pulses from the controller's input.</p>	<p>D: 60:00 mm:ss</p> <p>R: 0 to 960:00 mm:ss</p>

Alarms

Navigation: i-Vu® / Field Assistant: **Properties > Control Program > Alarms**

Point Name/Description	Range
Space Temperature – Indicates if the space temperature sensor exceeds the high or low alarm limit.	R: Normal/Alarm
Alarming Temperature – Indicates the space temperature value that caused the space temperature alarm. This value is only displayed when the Space Temperature alarm (above) is in Alarm .	R: -56 to 245 °F (-48.9 to 118.3 °C)
Alarm Limit Exceeded – Indicates the value of the space temperature alarm limit that caused the space temperature alarm condition. Value is only displayed when the Space Temperature alarm (above) is in Alarm .	R: -56 to 245 °F (-48.9 to 118.3 °C)
Space Temp Sensor – Indicates if the space temperature sensor fails.	R: Normal/Alarm
Wireless Battery Strength Alarm – Indicates one of the configured wireless space temperature sensors is displaying low charge strength.	R: Normal/Alarm
Wireless Signal Strength Alarm – Indicates one of the configured wireless space temperature sensors is displaying low radio signal strength.	R: Normal/Alarm
ZS/WS Sensor Configuration – Indicates if the ZS or wireless zone temperature sensor is not configured correctly.	R: Normal/Alarm
Indoor Air Quality – Indicates if the occupied CO ₂ level exceeds the Occupied High CO₂ Alarm Limit .	R: Normal/Alarm
Supply Air Temperature – Indicates if the supply air temperature exceeds the high temperature alarm limit or drops below the low temperature alarm limit.	R: Normal/Alarm
Filter – Indicates if the filter's runtime hours exceeds the runtime alarm limit.	R: Clean/Dirty
Space Relative Humidity – Indicates if the relative humidity exceeds the high RH alarm limit.	R: Normal/Alarm
Network OAT - Indicates if the controller is not receiving a valid OAT value over the network.	R: Normal/Alarm
Airside Linkage Status – If the controller is the VVT Master, Alarm indicates that it lost Linkage communications with the air source. If the controller is a slave, Alarm indicates that it lost Linkage communications with the VVT master.	R: Normal/Alarm

Linkage

Navigation: i-Vu® / Field Assistant: **Properties > Control Program > Linkage**

Point Name/Description	Default/Range								
Airside Linkage									
Click Linkage Collector/Linkage Provider to access the microblock popup's Summary and Details tabs. See the microblock popup's Help for more detailed explanations.									
Linkage Collector – For a VAV Master, set the Number of Providers to the total number of controllers that will report to the Master, including the Master. For a slave, the Number of Providers is 1 . See <i>Linkage</i> (page 56) for additional information.	D: 1 R: 1 to 64								
Linkage Provider – Depends on this controller's function.									
<table border="1"> <thead> <tr> <th>If the controller is...</th> <th>Enter the MS/TP network number and MAC address of...</th> </tr> </thead> <tbody> <tr> <td>The main VAV Master</td> <td>The linked air source controller</td> </tr> <tr> <td>A sub-master</td> <td>The main VAV Master</td> </tr> <tr> <td>A slave that is not on the same MS/TP network as its master</td> <td>Its masters</td> </tr> </tbody> </table>	If the controller is...	Enter the MS/TP network number and MAC address of...	The main VAV Master	The linked air source controller	A sub-master	The main VAV Master	A slave that is not on the same MS/TP network as its master	Its masters	
If the controller is...	Enter the MS/TP network number and MAC address of...								
The main VAV Master	The linked air source controller								
A sub-master	The main VAV Master								
A slave that is not on the same MS/TP network as its master	Its masters								
Network Number	D: 0 R: 0 to 65,535								
Address	D: 0 R: 0 to 127								
NOTE If you change the Network Number or Address , you must use the i-Vu® application or Field Assistant to cycle power to the controller for the changes to take effect.									
Airside Linkage Status – If Active , the controller is part of a linked system. If Not Active , the controller is a stand-alone device.	R: Not Active/Active								
Linkage Zone Type – Select whether the controller is a Master or a slave. Select VAV Master if the controller is the Master or a sub-master in a VAV application. Select VVT Master only if the controller is the Master in a VVT application. VVT applications do not support sub-masters.	D: Slave R: Slave VVT Master VAV Master								
Inhibit Heating Call from this zone? - VVT system only. If Yes , the VVT Master ignores this controller as a heating caller.	D: No R: No/Yes								
Active Heating Caller? – VVT system only. Determines if the zone will be counted as a heat caller for system heating when the zone has a local demand for heat.	D: Yes R: No/Yes								
Inhibit Cooling Call from this zone? - VVT system only. If Yes , the VVT Master ignores this controller as a cooling caller.	D: No R: No/Yes								

Point Name/Description	Default/Range
Active Cooling Caller? – VVT system only. Determines if the zone will be counted as a cool caller for system cooling when the zone has a local demand for cooling.	D: Yes R: No/Yes
Linkage Callers – VVT system only. The minimum number of zones required to make the air source go into heating or cooling mode. 1 is typical for systems with 8 zones or less. For larger systems, increase the number by 1 for each 6 zones. For example, 3 linkage callers for a 20 zone system.	D: 1 R: 1 to 32
System Mode Reselect Timer (minutes) – Applies only to a VVT master. Defines how long the system continues to operate in the current mode before it reassesses all zones while the current demand is still active.	D: 30 R: 10 to 120
Linkage RH Type – Determines if the VVT or VAV Master sends to the air source the average or maximum values of all linked zone controllers that have a relative humidity (RH) sensor.	D: Avg R: Avg/Max
Linkage IAQ Type – Determines if the Master controller sends to the air source the average or maximum values of all linked zone controllers that have a CO ₂ sensor for DCV and IAQ control.	D: Max R: Avg/Max
Air Source Mode – If Airside Linkage Status is Active , this is the current mode of the linked air source. If Airside Linkage Status is Not Active , this is the mode of the air source as determined by the zone controller's SAT sensor.	R: OFF WARMUP HEAT COOL FREECOOL PRESSURE EVAC VENT
Air Source Supply Air Temp – Displays the air source's SAT when Airside Linkage Status is Active .	R: -56 to 245 °F (-48.9 to 118.3 °C)
Air Source Static Pressure – Displays the air source's supply static pressure when Airside Linkage Status is Active .	R: 0 to 5.0 in wc (0 to 1.245 kPa)
Air Source Outdoor Air Temp – Displays the air source's OAT when Airside Linkage Status is Active .	R: -56 to 245 °F (-48.9 to 118.3 °C)

I/O Points

Navigation: i-Vu® / Field Assistant: **Properties > I/O Points**



WARNINGS

- Do not change the **Value**, **Offset/Polarity**, **Exp:Num**, **I/O Type**, **Sensor/Actuator Type**, **Min/Max**, or **Resolution** I/O configuration parameter for the points listed below. Changing these parameters could cause improper control and/or equipment damage.
- Use extreme caution if locking a point as this may also cause improper control and/or equipment damage.

Point Name/Description	Default/Range
SPT Sensor/Zone Temp SPT Sensor - (For the SPT Standard, SPT Plus, and SPT Pro sensors only). Sensor configurations on the microblock's Properties > Details tab are listed below. For more information, see the <i>Carrier Sensors Installation Guide</i> .	R: -56 to 245 °F (-48.9 to 118.3 °C)
Do not adjust the following settings: Min Present Value - Minimum present value the sensor transmits before indicating an alarm.	D: 45 °F (7.2 °C)+
Max Present Value - Maximum present value the sensor transmits before indicating an alarm.	D: 96 °F (35.5 °C)
Setpoint Adjustment: Max Adjust - The amount that a user may adjust the setpoint at the sensors.	D: 5Δ °F (2.7Δ °C) R: 0 to 15Δ °F (0 to 8.3Δ °C)
Reset setpoint adjust to zero when unoccupied - Resets the setpoint bias to zero when the controller transitions to unoccupied..	D: Off
Timed Local Override: Allow Continuous (SPT Pro only) - If checked, a user can press the sensor's local override button until the Max Accum value is reached, then press one more time to have a continuous override until the next occupied period or until the user cancels the override. The display shows On during a continuous override.	D: Off R: Off/On
Each Pulse - The amount of time added to the total override time when a user pushes the sensor's override button.	D: 30:00 mm:ss R: 0:00 to 1440:00 mm:ss
Max Accum - The maximum amount of override time accumulated when a user pushes the sensor's override button.	D: 240:00 mm:ss R: 0:00 to 2000:00 mm:ss
Cancel override - How long a user must push the sensor's override button to cancel an override.	D: 3 seconds R: 0 to 60 seconds

Point Name/Description	Default/Range
Sensor Array: Sensor calculation method - When using multiple SPT sensors, select the process variable to be passed to the controller..	D: Avg R: Avg, Min, Max
BACnet configuration: Network Visible - Must be enabled for other BACnet objects to read or write to this point, and for this point to generate alarms.	D: Enabled
Object Name - Do <u>not</u> change.	D: zone_temp
CO2 Sensor - The current voltage of the controller's RH/CO2 input.	R: 0 to 5 Vdc
Flow Control / Flow Input - The current value of the controller's flow sensor input.	R: 0 to 99999 cfm (liters/second)
RH Sensor - The current voltage of the controller's RH/CO2 input.	R: 0 to 5 Vdc
T55 Zone Temp - The value of the controller's T55 space temperature sensor input.	R: -56 to 245 °F (-48.9 to 118.3 °C)
SAT Sensor - The current value of the controller's SAT input.	R: R:-56 to 140 °F (-48.9 to 60 °C)
WS Battery Strength % — Displays charge strength indicated on the wireless space temperature sensor. If there are multiple wireless sensors, it displays the lowest value.	R: _%
WS Signal Strength % — Displays radio signal strength of the wireless space temperature sensor. If there are multiple wireless sensors, it displays the lowest value.	R: _%
Zone Humidity - The value provided by the controller's ZS or wireless sensor (if present). See details below.	R: _%
Zone Temp - The value provided by the controller's ZS or wireless sensor (if present).	R: _F°
ZS Zone CO2 - IAQ/CO2 signal received from CO2-enabled ZS Sensor(s).	R: _ppm

ZS/WS Sensors	
<p>The following properties apply to the ZS or wireless Standard, ZS or wireless Plus, and ZS or wireless Pro only. Sensor configurations on the microblock's Properties > Details tab are listed below for:</p> <ul style="list-style-type: none"> • Zone Humidity • Zone Temp • ZS Zone CO2 	
Default Value - The value that outputs when communication of all enabled sensors fails or during sensor startup. The default value is used for each sensor's corrected value in the i-Vu® system when the Valid? output is False (Off).	D: -999 R: -999 to 999
Sensor Configuration table <ul style="list-style-type: none"> • (Index) Area - The Index number corresponds to the sensors defined in Configuration > Service Configuration > Sensor Binder. (Ctrl+click the property name. See <i>Service Configuration</i> (page 83).) 	D: (1) Main ZS/WS Sensor R: (1) to (5)

<ul style="list-style-type: none"> • Use – Check Enable for each sensor that you want to include in the combination algorithm used to determine the output value. 	D: Enabled index (1) R: checked or unchecked
<ul style="list-style-type: none"> • Calibration – If needed, enter a Calculated Value by adding the Calibration to the Raw Value for each ZS or wireless sensor. 	D: 0 to 10
Combination Algorithm – If using more than one ZS or wireless sensor, select how the enabled sensors' values are to be combined to determine the output value. When the calculation is performed, only sensors with a valid value will be included.	D: Average R: Average Maximum Minimum
Input Smoothing – If the raw value from the sensor changes frequently, you can select one of the following options to send out an average of several readings on the output wire. <ul style="list-style-type: none"> • None - The raw value • Minimum - The average of the last 2 readings • Medium - The average of the last 5 readings • Maximum - The average of the last 9 readings 	D: Medium R: None Minimum Medium Maximum
Show on sensors – Select Local Value to have each enabled sensor display its individual sensed value, or Calculated Value to have each sensor display the value determined by the Combination Algorithm .	D: Calculated Value R: Calculated Value Local Value
Display Resolution – Defines the resolution of the value to be displayed on the sensor. For example, 1 displays only integers (e.g., 74) and 0.5 displays values to the nearest 0.5 (e.g., 74.5).	D: 1 R: 1000 100 10 1 0.5 0.1 0.01 0.001
COV Increment – To reduce Rnet traffic, you can force the microblock to update its output only when the sensed value changes by more than the COV Increment.	D: .1 R: 0 to 100
Occupancy Contact State – The current hardware state of the controller's REMOTE input.	R: Open/Closed
Sensor Invalid – This internal input monitors the communication between the controller and the SPT sensor. Off indicates communication is normal.	R: Off/On
Rnet Sensed Occupancy – Displays occupancy status detected by wireless infrared motion sensor.	R: Off/On
Hot Water Valve – The current value of the controller's HWV/ACT output.	R: 0 to 100%
Heating Stage 1 – The current hardware state of the controller's HEAT1 output.	R: Off/On
Heating Stage 2 – The current hardware state of the controller's HEAT2 output.	R: Off/On
Fan S/S or EH 3 – The current hardware state of the controller's FAN/HEAT3 output. The function of this output depends on the terminal type.	R: Off/On

Appendix B: VAV terminal modes

Air Source Mode	Temperature Control Requirement	Terminal Type	Aux Heat	Terminal Mode	Damper Control (Damper Setpoint used)	Heat Control	Fan Control	
Off	None	All	N/A	Off	Hold Damper @ 70% (None)	Disable	Disable	
	Cooling	All	N/A	Off	Hold Damper @ 70% (None)	Disable	Disable	
	Heating	Single Duct	N/A	Off	Hold Damper @ 70% (None)	Disable	N/A	
		Series or Parallel Fan	No	Off	Hold Damper @ 70% (None)	Disable	Disable	
		Series Fan	Yes	Heating	Hold Damper @ 70% (None)	Enable	Enable	
	Parallel Fan	Yes	Heating	Close Damper (None)	Enable	Enable		
Vent	None	Single Duct	N/A	Heating	Minimum cfm (Vent)	Disable	N/A	
		Series Fan	N/A	Vent	Minimum cfm (Vent)	Disable	Enable	
		Parallel Fan	N/A	Vent	Minimum cfm (Vent)	Disable	Disable	
	Cooling	Single Duct	N/A	Cooling	Modulate Min/Max cfm (Cool)	Disable	N/A	
		Series Fan	N/A	Cooling	Modulate Min/Max cfm (Cool)	Disable	Enable	
		Parallel Fan	N/A	Cooling	Modulate Min/Max cfm (Cool)	Disable	Disable	
	Heating	Single Duct, Parallel Fan	No	Cooling	Minimum cfm (Cool)	Disable	Disable	
		Series Fan	No	Heating	Minimum cfm (Cool)	Disable	Enable	
		Single Duct	Yes	Reheat	Minimum cfm	Enable	N/A	
		Series or Parallel Fan	Yes	Heating	Minimum cfm (Cool)	Enable	Enable	
	Cool, Freecool	None	Single Duct	N/A	Vent	Minimum cfm (Cool)	Disable	N/A
			Series Fan	N/A	Vent	Minimum cfm (Cool)	Disable	Enable
Parallel Fan			N/A	Vent	Minimum cfm (Cool)	Disable	Disable	
Cooling		Single Duct	N/A	Cooling	Modulate Min/Max cfm (Cool)	Disable	Disable	
		Series Fan	N/A	Cooling	Modulate Min/Max cfm (Cool)	Disable	Enable	
		Parallel Fan	N/A	Cooling	Modulate Min/Max cfm (Cool)	Disable	Disable	
Heating		Single Duct, Parallel Fan	No	Cooling	Minimum cfm (Cool)	Disable	Disable	
		Series Fan	No	Heating	Minimum cfm (Cool)	Disable	Enable	
		Single Duct	Yes	Reheat	Minimum cfm	Enable	N/A	
		Series or Parallel Fan	Yes	Heating	Minimum cfm (Cool)	Enable	Enable	

Appendix B: VAV terminal modes

Air Source Mode	Temperature Control Requirement	Terminal Type	Aux Heat	Terminal Mode	Damper Control (Damper Setpoint used)	Heat Control	Fan Control	
Heat, Warmup	None	Single Duct, Parallel Fan	N/A	Heating	Minimum cfm (Heat)	Disable	Disable	
		Series Fan	N/A	Heating	Minimum cfm (Heat)	Disable	Enable	
	Cooling	Single Duct, Parallel Fan	N/A	Heating	Minimum cfm (Heat)	Disable	Disable	
		Series Fan	N/A	Heating	Minimum cfm (Heat)	Disable	Enable	
	Heating	Single Duct	No	Heating	Modulate Min/Max cfm (Heat)	Disable	N/A	
		Single Duct	Yes	Heating	Modulate Min/Max cfm (Heat)	Enable	N/A	
		Series or Parallel Fan	No	Heating	Modulate Min/Max cfm (Heat)	Disable	Enable	
		Series or Parallel Fan	Yes	Heating	Modulate Min/Max cfm (Heat)	Enable	Enable	
Pressurization (Linked air source only)	None	Single Duct, Parallel Fan	N/A	Pressurize	Minimum cfm (Cool)	Disable	Disable	
		Series Fan	N/A	Pressurize	Minimum cfm (Cool)	Disable	Enable	
	Cooling	Single Duct, Parallel Fan	N/A	Pressurize	Minimum cfm (Cool)	Disable	Disable	
		Series Fan	N/A	Pressurize	Minimum cfm (Cool)	Disable	Enable	
	Heating	Single Duct, Parallel Fan	No	Pressurize	Minimum cfm (Cool)	Disable	Disable	
		Series Fan	No	Pressurize	Maximum Cool cfm (Cool)	Disable	Enable	
		Single Duct, Parallel Fan	Yes	Pressurize	Maximum Cool cfm (Cool)	Disable	Disable	
		Series Fan	Yes	Pressurize	Maximum Cool cfm (Cool)	Enable	Enable	
	Evacuation/ Shutdown (Linked)	All	All	N/A	Evac	Close Damper	Disable	Disable

Appendix C: ZS Sensor display for VAV Zone II

Property	ZS Screen	Rnet Tag	Rnet Text ¹	Description
Active Alarms	Diagnostic	1550	-nonE StP-AL SPco2-AL SP_rH-AL Sat-AL	No Active Alarms Zone Temp Alarm Zone CO2 Alarm Zone Humidity Alarm Supply Air Temp Alarm
Active Maintenance	Diagnostic	1551	-nonE- SnSr-FLt Filtr-dtY Linc-FLt	No Active Maintenance Sensor Fault Dirty Filter Linkage Fault
Active Air Source Linkage Mode	Diagnostic	1552	OFF hEAt-uP hEAt cooL FrEEcool PrESSrZE EuAcuATE vEnt no-Linc	Off Warm-up Heat Cool Freecool Pressurize Evacuate Vent Linkage Not Active
Supply Air Temp	Info	304		Air Source Supply Air Temp, if available
Air Flow Percentage of Nominal	Info	308		% of design air flow
Outdoor Air Temperature	Info	 F°		Outside Air Temp

¹ Rnet text is the scrolling text that appears on the ZS Pro Sensor's display.

NOTES

- To view properties on the **Diagnostic** Screen, hold the **i** button for 3 seconds. Tap the button to cycle through information to help troubleshoot your system.
- The Rnet tag is displayed on the ZS sensor display.
- To view properties on the Info Screen, press the **i** button. Tap the button to cycle through information.

Appendix D: BACnet points list for the VAV Zone II Fan Terminal

Point Name	Point Access	Units	Default Value	BACnet	
				BACnet Point Name	BACnet Object ID
Occupied Cooling Setpoint	R/W	°F	75	occ_cl_stpt	AV:3001
Occupied Heating Setpoint	R/W	°F	70	occ_ht_stpt	AV:3002
Unoccupied Cooling Setpoint	R/W	°F	90	unocc_cl_stpt	AV:3003
Unoccupied Heating Setpoint	R/W	°F	60	unocc_ht_stpt	AV:3004
Occupancy Contact State	R	0=Open 1=Closed		occ_switch	BI:1001
Air Source Outdoor Air Temp	R	°F		link_ahu_oat	AV:2609
Air Source Static Pressure	R	in H2O		link_ahu_static	AV:2610
Air Source Supply Air Temp	R	°F		link_sat	AV:2608
Baseboard Heating Capacity	R	%		bas_bd_ht_cap	AV:2031
Cooling Demand Level	R			cool_demand_level	AV:9006
Damper Position	R	%		dpr_pos	AV:1013
Effective Cool Setpoint	R	°F		eff_cl_stpt	AV:3005
Effective Heat Setpoint	R	°F		eff_ht_stpt	AV:3006
Fan Off Delay	R/W	sec	120	fan_delay_off	AV:9024
Filter Runtime	R	hr		filter_rntm	AV:2015
Filter Service Alarm Timer	R/W	hr	0	filter_service_hrs	AV:2019
Heating Capacity	R	%		htg_cap	AV:2030
Heating Demand Level	R			heat_demand_level	AV:9036
Heating Lockout Temperature	R/W	°F	70	oat_ht_lockout	AV:9003
Indoor Air Quality CO2 (ppm)	R	ppm		iaq	AV:1009
lux sensor BACnet accessible	R			lux_bn	
Occ Override Delay	R/W	min	15	occ_ovr_delay	AV:9028
Occupied RH Control Setpoint	R/W	%rh	65	occ_dehum_stpt	AV:3011
Outdoor Air Temperature	R	°F		oa_temp	AV:1003
Override Time Remaining	R	min		ovrde_time	AV:2016
Power Fail Restart Delay	R/W	sec	60	start_delay	AV:9007
Setpoint Adjustment	R	°F		stpt_adj	AV:1006
Setpoint Adjustment Range	R/W	°^F	2	stpt_adj_range	AV:9015
Space Relative Humidity	R	%rh		space_rh	AV:1011
Space Temperature - Prime Variable	R	°F		space_temp	AV:2007
Standby Offset	R/W	°F	0	stdby_offset	AV:1017
Supply Air Temperature	R	°F		sa_temp	AV:1008
System Outdoor Air Temperature	R/W	°F	-999	system_oat	AV:1901
System Setpoint Adjustment	R/W	°F	-999	system_stpt_adj	AV:1913
System Space AQ	R/W	ppm	-999	system_iaq	AV:1903
System Space RH	R/W	%	-999	system_rh	AV:1904
System Space Temperature	R/W	°F	-999	system_spt	AV:1902
Airside Linkage Status	R	0=Not Active 1=Active		a_link_status	BV:2601
Fan	R	0=Off 1=On		sfan_status	BV:1003
Heat Enable	R/W	0=Disable 1=Enable	Active (1)	ht_enable	BV:1012
Occupancy Status	R	0=Unoccupied 1=Occupied		occ_status	BV:2008

Point Name	Point Access	Units	Default Value	BACnet	
				BACnet Point Name	BACnet Object ID
Occupied Cooling Setpoint	R/W	°F	75	occ_cl_stpt	AV:3001
Reset Filter Alarm	R/W	0=Off 1=On	Inactive (0)	filter_rntm_clr	BV:7517
Setpoint Adjustment	R/W	0=Disable 1=Enable	Active (1)	stpt_adj_enable	BV:1013
Shutdown	R/W	0=Inactive 1=Active	Active (1)	shutdown	BV:9001
VAV Reheat	R/W	0=Disable 1=Enable	Active (1)	vav_reheat	BV:1029
Air Source Mode	R	1=OFF 2=WARM-UP 3=HEAT 4=COOL 5=FREECOOL 6=PRESSURIZE 7=EVACUATE 8=VENT		link_ahu_mode	MSV:2005
BAS On / Off	R/W	1=Inactive 2=Occupied 3=Unoccupied	1	keypad_ovrde	MSV:1001
Optimal Start Type	R/W	1=None 2=Temp Compensated 3=Learning Adaptive	2	start_type	MSV:2009
Space Temp Source	R	1=Sensor Failure 2=SPT Sensor 3=T55 / T56 4=Network 5=Airside Linkage 6=Locked Value 7=ZS Sensor 8=Wireless Sensor		spt_status	MSV:2003
Terminal Mode	R	1=Off 2=Heating 3=Warm-Up 4=Vent 5=N/A 6=Cooling 7=Dehumidify 8=Reheat 9=Pressurize 10=Evacuate 11=Shutdown 12=IAQ Override 13=Air Balancing		terminal_status	MSV:2006
Terminal Type	R	1=Single Duct 2=Parallel Fan 3=Series Fan		terminal_type	MSV:2007
Zone Type	R	1=Slave 2=VVT Master 3=VAV Master		zone_type	MSV:2008
Airside Linkage Status	R	0=Normal 1=Alarm		air_linkage_fail	BV:7030
Filter	R	0=Clean 1=Dirty		filter_alarm	BV:7017
High SPT	R	0=Normal 1=Alarm		spt_hi_alarm	BV:7011
Indoor Air Quality	R	0=Normal 1=Alarm		iaq_alarm	BV:7005
Low SPT	R	0=Normal		spt_lo_alarm	BV:7012

Appendix D: BACnet points list for the VAV Zone II Fan Terminal

Point Name	Point Access	Units	Default Value	BACnet	
				BACnet Point Name	BACnet Object ID
Occupied Cooling Setpoint	R/W	°F	75	occ_cl_stpt	AV:3001
		1=Alarm			
Network OAT	R	0=Normal 1=Alarm		oat_fail	BV:7029
Space Relative Humidity	R	0=Normal 1=Alarm		sprh_hi_alarm	BV:7018
Space Temp Sensor	R	0=Normal 1=Alarm		spt_fail	BV:7001
Supply Air Temperature	R	0=Normal 1=Alarm		sat_alarm	BV:7004
Wireless Battery Strength Alarm	R	0=Normal 1=Alarm		ws_batt_alarm	BV:7064
Wireless Signal Strength Alarm	R	0=Normal 1=Alarm		ws_sig_alarm	BV:7065
ZS/WS Sensor Configuration	R	0=Normal 1=Alarm		zs_config_fail	BV:7055

Document revision history

Important changes to this document are listed below. Minor changes such as typographical or formatting errors are not listed.

Date	Topic	Change description	Code*
1/25/19	Wiring devices to the VAV Zone II's Rnet port	Removed star configuration from the first paragraph.	X-TS-TS-0
	Specifications	Added surge CAUTION to Protection specification.	X-TS-AK-E-CC
12/17/18	Wiring the VAV Zone II for power > To wire the controller for power.	Added photograph of lifting up the cover.	CA-H-RE-E-CC-JS
	Mounting the VAV Zone II > To mount the controller and actuator	Added caution stating that you must use the bushing, O-ring, and screws that are shipped with the VAV Zone II, along with applicable graphic.	CA-H-RE-E-CC-JS
10/30/18	Wiring sensors to the VAV Zone II's inputs > To wire the T55 sensor to the controller	Removed reference to SPT sensors.	C-D
	Sequence of operation > Temperature sensors	Removed SPT sensors.	C-D
	Wiring equipment to the VAV Zone II's outputs > Wiring diagram legend	Removed SPT sensors. Now shown as "Space temp sensor" in diagrams.	C-D
8/28/18	Wiring devices to the VAV Zone II's Rnet port	Added TruVu™ ET Display. Made one topic for overview and wiring for each device. Removed SPT sensor detail.	C-D
	Specifications	Reworded Rnet port specification and added power supplied by Rnet port. Added first paragraph to Protection specification.	X-H-JS-0
8/2/18	To wire the CO2 sensor to the controller	Diagram for the #33ZCT55CO2 corrected to show wiring to J5 - 3 and 2, not 1 and 2.	C-TS-CP-E-WB

* For internal use only



CARRIER CORPORATION ©2019

A member of the United Technologies Corporation family · Stock symbol UTX · Catalog No. 11-808-602-01 · 1/25/2019