

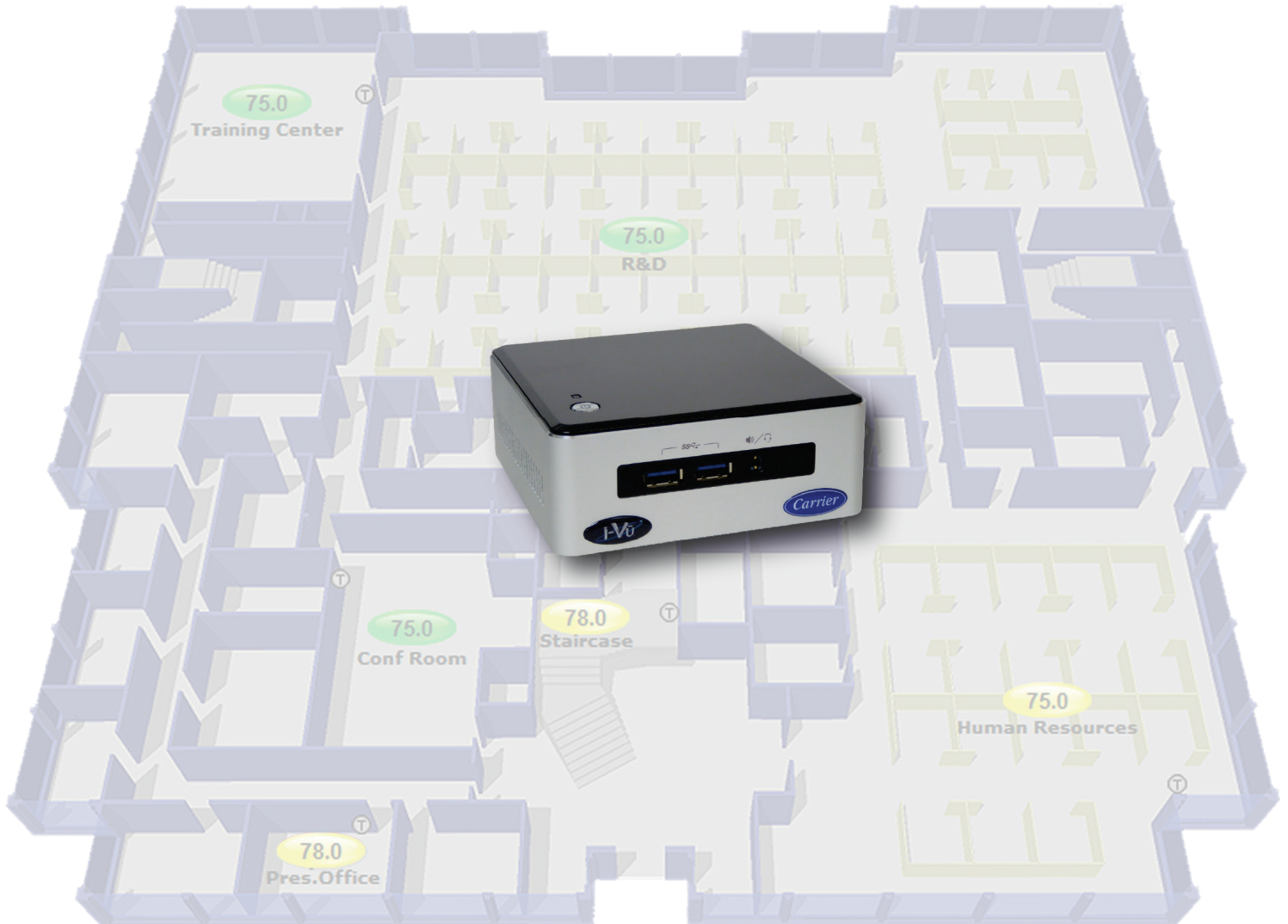

United Technologies
turn to the experts

i-Vu® Standard/Plus v7.0

Help





Verify that you have the most current version of this document from www.hvacpartners.com or your local Carrier office.

Important changes are listed in **Document revision history** at the end of this document.

CARRIER CORPORATION © 2018. All rights reserved throughout the world. i-Vu is a registered trademark of Carrier Corporation. All other trademarks are the property of their respective owners.

The contents of this guide and the associated Carrier software are property of Carrier Corporation and its respective licensors, and are protected by copyright. For more information on the software and licensing, see the About section in the software's Help menu.

The content of this guide is furnished for informational use only and is subject to change without notice. Carrier Corporation assumes no responsibility or liability for any errors or inaccuracies that may appear in the informational content contained in this guide. This document contains no technical data controlled by the EAR or ITAR.

Contents

What is the i-Vu® Standard/Plus application?	1
i-Vu® Standard and Plus web server specifications	2
i-Vu® tools.....	2
What's new in v7.0	4
What's new in the i-Vu® Standard/Plus v7.0 application.....	4
What's new in the ViewBuilder application	5
What's new in the Snap application	5
Setting up i-Vu® client devices and web browsers	6
Setting up and using a computer with the i-Vu® system.....	7
Setting up and using a web browser to view the i-Vu® interface	7
To set up and use Internet Explorer.....	7
To set up and use Microsoft Edge.....	8
To set up and use Mozilla Firefox.....	9
To set up and use Google Chrome	10
To set up and use Safari.....	11
Getting to know the Interface	13
Navigating the system	14
To show, hide, or resize the navigation tree	15
Zooming in and out	16
Using right-click menus.....	17
To print the action pane.....	18
Colors and status in the i-Vu® interface	18
Colors and setpoints.....	19
Using System Options for administrative utilities	20
My Settings tab	21
Operators tab.....	21
General tab	25
Management Tool.....	28
Security tab.....	30
Advanced password policy	31
Update tab	31
Daylight Saving tab.....	34
Add-ons tab.....	34
Working with equipment in the interface	36
Graphics pages	38
To attach a graphic in the i-Vu® interface	39
To edit a graphic from the i-Vu® application in ViewBuilder	39
To control equipment using an interactive zone sensor.....	40
Properties pages	41
To view or edit properties on a Properties page.....	41
Logic pages	42
To view a Logic page	42
To locate a microblock, section, or label	42
To change properties, alarms, or trends.....	43
Using a Logic page to troubleshoot.....	43
Changing multiple microblock properties	44
To use Global Modify.....	44
To use Global Copy.....	46
Checking controller status	47
Status messages.....	48
Handling parameter mismatches.....	51

Managing setpoints	52
Adjust setpoints.....	54
Demand Control	54
Configuring Optimal Start	56
Optimal Start	56
Optimal Start Type.....	57
Schedules	59
To view schedules.....	59
To print schedules.....	60
To apply a schedule to equipment.....	60
To apply a schedule to a group of items	62
To edit or delete a schedule.....	63
Effective schedules.....	63
I-Vu® CCN schedules	65
Alarms	66
Viewing, acknowledging, and deleting alarms	67
To view alarms in the i-Vu® interface	67
To control which alarms you see	69
To acknowledge alarms	70
To delete alarms.....	71
To receive audible notification of alarms.....	72
Setting up alarm actions	72
Alarm Popup	73
Send E-mail.....	76
Send Web Service Request	78
Setting up an alarm source in the i-Vu® interface	79
To set up, edit, or disable alarm sources.....	79
To view all instances of an alarm source.....	81
To simulate an alarm	81
Alarm categories	82
Edit alarm messages.....	82
Using field codes	83
Formatting field codes	83
Field Codes	84
Trends	88
To collect trend data for a point	89
Viewing a built-in, single-point trend graph	90
Creating a custom trend graph	91
To create a custom trend graph	91
To edit a custom trend graph	92
Using trend graphs	93
To view trend data in a spreadsheet program.....	94
Reports	95
Preconfigured reports	95
To run a preconfigured report	97
Custom reports	98
To run a custom report	98
To delete a custom report.....	98
To export or import a custom report	99
Custom report as the source for a Graphics page	100
To create a PDF, XLS, or CSV file	100
Scheduling reports	101
To schedule a report	101
To manage scheduled reports.....	102







Working with legacy (v6.5 and earlier) custom reports	103
To create an Equipment Summary report.....	103
To create an Equipment Values report	104
To create a Trend Samples report.....	106
To save a v6.5 or earlier custom report's design	107
To edit or delete a custom report.....	107
Setting up devices in the i-Vu® application	108
Setting up i-Vu® Open or i-Vu® XT devices in the i-Vu® application	108
Find and upload routers and controllers	108
Verify network and device settings	109
Working with control programs	110
Reload, create, or edit a control program in EquipmentBuilder or Snap.....	111
Add or delete a custom control program	113
To edit a control program on an i-Vu® Pro client.....	114
Setting up CCN devices in the i-Vu® application	115
To find and download CCN devices.....	115
To assign and download a custom CCN equipment file	116
To view an equipment's CCN tables.....	118
Working with Universal and Comfort Controllers (CCN)	119
Working with Terminal System Managers	123
Integrating third-party data into the i-Vu® system	127
To discover third party BACnet networks, devices, and objects.....	128
To determine the number of third-party points used in a controller	129
To configure LonWorks points using the LonWorks Integration Tool.....	129
Configuring your system	130
Work with controllers, set up Linkage, and perform Test and Balance	130
i-Vu® network connection options and requirements	130
Network security.....	134
Using a Modstat to troubleshoot your system	134
Commissioning equipment.....	138
Commissioning equipment using Field Assistant.....	146
Downloading to controllers	148
Create navigation tree for the User view.....	151
Monitoring and controlling equipment	153
To lock a BACnet point or value	153
To force a CCN point value	154
To set up peer caching.....	155
Working with drivers in the i-Vu® interface	156
To view or change a driver.....	156
Working with touchscreen or BACview® files in the i-Vu® interface	158
To select a different screen file	158
To edit a screen file on an i-Vu® client	159
System Management	160
Backup data from Management Tool	160
Restore data from backup	161
Restore factory defaults	161
Restore i-Vu® system	161
Update the SAL library	162
Synchronize to system time.....	164
Advanced topics	165
Troubleshooting and communications	165
Troubleshooting BACnet bindings	165
Communicating using PuTTY	165
Communicating using HyperTerminal	167

Troubleshooting networks	169
Manual commands.....	169
Using DEBUG MODE	174
Defining i-Vu® paths	174
Absolute path	175
Relative path	175
Determining a path or microblock property.....	176
Document revision history	178

What is the i-Vu® Standard/Plus application?

An i-Vu® system is a web-based building automation system that can be accessed from anywhere in the world through a web browser, without the need for special software on the workstation. Through the web browser, you can perform building management functions such as:

- adjust setpoints and other control parameters
- set and change schedules
- graphically trend important building conditions
- view and acknowledge alarms
- run preconfigured and custom reports on energy usage, occupant overrides, and much more

	i-Vu® Standard	i-Vu® Plus
Part number	CIV-OPN	CIV-OPNPL
Networks supported	BACnet and CCN	BACnet and CCN
Routing devices	<ul style="list-style-type: none"> • USB-CCN Adapter • USB-MS/TP Adapter • Open/CCN routers • Carrier® ChillerVu™ • i-Vu XT Router 	<ul style="list-style-type: none"> • USB-CCN Adapter • USB-MS/TP Adapter • Open/CCN Routers • Open/CCN Links • Carrier® ChillerVu™ • i-Vu XT Routers
Maximum controllers supported	750	750
Trend storage	7 days	62 days
Alarms storage	500	500
Audit Log storage	30 days	30 days
Custom Equipment and Trend Reports		
Tenant Override Billing Reports		
Weather Add-on		
Web Services (XML/SOAP) Data Access		
BACnet/Modbus®/LonWorks® integration		
Location-dependent access		

i-Vu® Standard and Plus web server specifications

i-Vu® web server	
Operating temperature	32°F to 122°F (0°C to 50°C). For indoor use only
Storage temperature	-4°F to 158°F (-20°C to 70°C)
Storage humidity	5% to 90% RH
Weight	2.4 lb (1.09 kg)
Dimensions	4.52 in. (115 mm) deep x 4.37 in. (111 mm) wide x 1.9 in. (48.7 mm) high
USB ports	4 USB 3.0 ports for i-Vu® network connection or for backing up/restoring system data
LAN port	Integrated Intel® 10/100/1000 Mbps port for Ethernet
VESA mounting plate	Attach the web server to the back of a flat monitor
Mini DisplayPorts	Connect to a monitor for troubleshooting
Safety Compliance	IEC, UL, EN, CAN/CSA
Environmental Compliance	RoHS 2011/65/EU, WEEE 2002/96/EC, China RoHS MII Order #39
EMC Compliance	FCC CFR Title 47, Chapter I, Part 15, Subparts A, B

i-Vu® tools

Develop and configure graphics and a system database for your i-Vu® system using the following i-Vu® tools.

NOTE The i-Vu® tools have a built-in license that expires 2 years after the software is released. Contact Carrier Control Systems Support for updates concerning your license.

Use...	To...
ViewBuilder	Create or edit graphics

Tech tools for the Installer only:

Use...	To...
EquipmentBuilder	Build or edit control programs (.equipment files) for programmable controllers. Can also produce graphics, sequence of operation, and screen files
Alarm Notification	Receive a message on any networked computer that is running the i-Vu® Alarm Notification Client application
Virtual BACview®	View and change property values and the controller's real time clock

Use...	To...
BBMD Configuration Tool	Configure BACnet/IP Broadcast Management Devices (BBMDs) NOTE If your system has multiple routers that reside on different IP subnets, you must set up one router on each IP subnet as a BACnet/IP Broadcast Management Device (BBMD).
MSTP Capture Utility	Capture BACnet traffic on MS/TP. It is intended for situations where Carrier Control Systems Support needs a network capture to troubleshoot communications.
Test & Balance	<ul style="list-style-type: none"> • Calibrate airflow in a VAV or VVT Zone controller • Calibrate the static pressure in a VVT Bypass controller • Commission air terminals • Override reheat and terminal fans NOTE Use Test & Balance to manipulate the controllers associated with an air source, but not the air source itself, or heating and cooling equipment, such as chillers and boilers.
Snap	Build custom control programs using individual blocks of programming code called microblocks
LonWorks Integration Tool	Generate the microblock addresses automatically for third-party LonWorks points
AppLoader	Use to download .clipping files to restore factory defaults and check Module Status (Modstat) through the Rnet port
Field Assistant	Service or start up and commission a piece of equipment or a network of controllers.

What's new in v7.0

What's new in the i-Vu® Standard/Plus application

Feature	Improvement
<i>Custom reports</i> (page 98)	<p>i-Vu® Plus only – v7.0 custom reports are managed through the new Report Manager.</p> <p>You can export one or more custom reports to a file so that they can be imported into another system.</p> <p>A custom report can provide data for the following new items on a Graphics page:</p> <ul style="list-style-type: none">• Data table• Chart• Color map <p>See <i>What's new in the ViewBuilder application</i> (page 5) for more information on the above items.</p> <p>NOTE To support upgraded systems, you can still create and access <i>legacy (v6.5 and earlier) custom reports</i> (page 103).</p>
<i>Scheduled Reports</i> (page 101)	<p>i-Vu® Plus only - You can set up a report to run on a recurring basis. The report is saved as a file (PDF, CSV, or XLS), and you can choose to have it automatically emailed to someone.</p>
<i>Send Web Service Request alarm action</i> (page 78)	<p>This new alarm action sends a web service request to a third-party server when an alarm occurs.</p>
<i>Email Server Configuration</i> (page 25)	<p>The Email Server Configuration settings, used by scheduled reports and the Send Email alarm action, are now located on the System Options > General tab.</p>
<i>Send Email alarm action</i> (page 76)	<p>This alarm action can use the default Email Server Configuration settings defined in System Options, or you can enter settings specific to the alarm action.</p>
<i>New FDD alarm categories</i> (page 82)	<p>i-Vu® now has two new alarm categories, FDD Comfort and FDD Energy.</p>
<i>Add-ons</i> (page 34)	<p>The i-Vu® Plus application now allows only signed add-ons that are supported by Carrier. The i-Vu® Standard application does not support add-ons.</p>
WAP device support	<p>This has been removed from the i-Vu® application. Smart phone support introduced in v6.5 replaced this functionality.</p>

What's new in the ViewBuilder application

Feature	Improvement
Local Variables	ViewBuilder now preserves local variables through cut/copy and paste, as well as when importing a .viewsymbol.
Layers	<ul style="list-style-type: none">ViewBuilder now preserves layers when importing a .viewsymbol.If cutting/copying a selection assigned to layers, you must hold Shift while pasting in a new file to preserve layer assignments.

What's new in the Snap application

Feature	Improvement
	Support for the following new optional features has been added to Snap. When released, you can download them from https://accounts.ivusystems.com/tsaplctrackweb.nsf/download under Technician Tools Software and Updates > v7.0 Installs and updates or http://hvacpartners.com/Pages/PS/Software/ControlsDownloads.aspx under I-Vu SAL Files and Updates .
Improved Edit Order	Provides more flexibility and reduces the time needed to create property pages for equipment.
Translation Assistance Tool	Simplifies the process of creating non-English control programs.

Setting up i-Vu® client devices and web browsers

The i-Vu® system can be viewed on the following client devices and web browsers.

Computers

The client computer should have at least:

- Dual core processor
- 1.5 GB RAM
- Communications link of 10 Mbps or higher

The i-Vu® application will work with slower computers and slower links, but the results may not be satisfactory.

A computer with this operating system...	Supports these web browsers...
Windows®	Google™ Chrome™ v66.0 or later ¹ Internet Explorer® v11 Desktop Microsoft® Edge v40 or later Mozilla® Firefox® v60.0 or later
Mac® OS X® (Apple® Mac only)	Safari® v11 or later ² Google Chrome v66.0 or later Mozilla Firefox v60.0 or later
Linux®	Google Chrome v66.0 or later Mozilla Firefox v60.0 or later

¹ Best performance

² Best performance unless browser is running on a Mac® Mini or a MacBook:

 **WARNING** If machine is running Mountain Lion 10.8x with an integrated Intel HD 400 graphics card, it will experience display issues. Use one of these workarounds for better performance:

- If an additional NVIDIA graphics card is available, manually switch the graphic card setting in MAC® OS X® to use that card.
- If not, use Google™ Chrome™ v66.0 or later.

Mobile devices

Device type	Platform support
Smart phone	Android™, iOS
Tablet	Android™, iOS, Surface™

NOTE Some functionality may be limited by the capability of the mobile device and operating system.

Setting up and using a computer with the i-Vu® system

- Set the monitor's screen resolution to a minimum of 1920 x 1080 with 32-bit color quality
- You may want to disable the computer's navigation sounds.

Mac only

NOTE The instructions below are for a Mac OS X 10.8. Other versions may vary slightly. See your computer's Help if necessary.

Computer settings	To change setting...
Enable right-clicking to see right-click menus:	
On a Mac	<ol style="list-style-type: none">1 Select System Preferences > Mouse.2 Click the drop-down list that points to the mouse's right-click button, then select Secondary Button.
On a MacBook	<ol style="list-style-type: none">1 Select System Preferences > Trackpad.2 Enable Secondary click.

The instructions in Help are for a Windows computer. For instructions that include the **Ctrl** key, replace **Ctrl** with **Command**. For example, replace **Ctrl+click** with **Command+click**.

Setting up and using a web browser to view the i-Vu® interface

To set up and use Internet Explorer

NOTES

- The instructions below are for Internet Explorer® 11. Other versions may vary slightly. See your web browser's Help if necessary.
- If the menu bar is not visible, right-click on the window's header, and then select **Menu bar**.

Web browser settings	To set in Internet Explorer...
Accept First-party and Third-party cookies	Tools > Internet Options > Privacy > Advanced button
Automatically check for newer versions of stored pages	Tools > Internet Options > General > Browsing history > Settings button

Web browser settings	To set in Internet Explorer...
Load ActiveX Control	Tools > Internet Options > Security > Custom Level button. Under ActiveX controls and plug-ins , set the following: <ul style="list-style-type: none"> • Download signed ActiveX controls > Prompt • Download unsigned ActiveX controls > Disable • Run ActiveX controls and plug-ins > Enable • Script ActiveX controls marked safe for scripting > Enable
Select Play animations in web pages	Tools > Internet Options > Advanced > under Multimedia
Disable all the options on the Explorer Bar	View > Explorer Bars
Disable web browser's pop-up blockers	Tools > Pop-up Blocker > Turn Off Pop-Up Blocker
Disable external toolbar pop-up blockers	Varies
Hide the web browser's toolbars	View > Toolbars
To...	Do the following...
Maximize the web browser window	Press F11 to turn full-screen mode on/off, or use the minimize/maximize button in the top right corner of the browser window.
Have 2 different users logged in to the i-Vu® system on the same computer	Start a new web browser session. Select File > New Session .
Clear browser cache	<ol style="list-style-type: none"> 1 Select Tools > Internet Options. 2 Click Delete. 3 If you had the i-Vu® system saved as a Favorite, uncheck Preserve Favorites website data. 4 Click Delete again.

To set up and use Microsoft Edge

The instructions below are for Microsoft® Edge.

Web browser settings	To set in Microsoft Edge...
Do not block cookies	More Actions > Settings > View Advanced Settings > Cookies
Disable web browser's pop-up blockers *	More Actions > Settings > View Advanced Settings > Block pop-ups

To...	Do the following...
Maximize the web browser window *	Use the minimize/maximize button in the top right corner of the browser window.
Have 2 different users logged in to the i-Vu® system on the same computer *	More Actions > New Window
Clear browser cache	More Actions > Settings > Clear browsing data > Clear

* Does not apply to Microsoft Edge on a phone.

To set up and use Mozilla Firefox

NOTES

- The instructions below are for Mozilla® Firefox® v60.0 on a Windows operating system. Other versions may vary slightly. See your web browser's Help if necessary.
- If the menu bar is not visible, right-click on the window's title bar, and then select **Menu bar**.
- If a message appears in the i-Vu® interface that includes the checkbox **Prevent this page from creating additional dialogs**, DO NOT check this box.

Web browser settings	To set in Firefox...
Disable Pop-up blocker	<ol style="list-style-type: none"> 1 Click Tools > Options > Privacy & Security. 2 Under Permissions, click Exceptions next to Block pop-up windows. 3 Type <code>http://</code> (or <code>https://</code>) and then the server name or IP address of your system. 4 Click Allow and then Save Changes.
Enable JavaScript	<ol style="list-style-type: none"> 1 In the address bar, type <code>about:config</code>, and then press Enter. 2 Click I accept the risk. 3 In the Search bar, type <code>javascript.enabled</code>. 4 If the value field shows true, JavaScript is enabled. If it shows false, right-click javascript:enabled, and then select Toggle.
Add-ons Manager	<p>Select Tools > Add-ons > Extensions. On this page, you can enable/disable installed add-ons such as:</p> <ul style="list-style-type: none"> • Adobe® Acrobat® Reader (to view PDF's) • QuickTime Plug-in (to play audible alarms) <p>Only installed Firefox add-ons will show up in the list.</p>

To...	Do the following...
Maximize the web browser window	Press F11 to turn full-screen mode on/off.
Clear browser cache	<ol style="list-style-type: none"> 1 Click Tools > Options > Privacy & Security. 2 Under Cookies and Site Data, click Clear Data. 3 Click Clear.
Have 2 different users logged in to the i-Vu® system on the same computer	Start a new web browser session. Select File > New Private Window .



To set up and use Google Chrome

NOTES

- The instructions below are for Google™ Chrome™ v66.0. Other versions may vary slightly. See your web browser's Help if necessary.
- If a message appears in the i-Vu® interface that includes the checkbox **Prevent this page from creating additional dialogs**, DO NOT check this box.

On a computer

Web browser settings	To set in Chrome...
Enable pop-ups	<ol style="list-style-type: none"> 1 Click  on the browser toolbar. 2 Select Settings. 3 Click Advanced at the bottom of the page. 4 Under Privacy and security, click Content settings. 5 Under Pop-ups > Allow, click ADD, and then type http:// (or https://) and then the server name or IP address of your system.

To...	Do the following...
Clear browser cache	<ol style="list-style-type: none"> 1 Click  on the browser toolbar. 2 Select More tools > Clear browsing data. 3 Select a time range in the drop-down list. 4 Check the types of information that you want to remove. 5 Click CLEAR DATA.
Maximize the web browser window	Press F11 on your keyboard to turn full-screen mode on/off.
Have 2 different users logged in to the i-Vu® system on the same computer	Start a new web browser session. Click  , then select New Incognito window .

On a Google Nexus

Web browser settings	In the Chrome menu...
Turn off desktop mode	Uncheck Request desktop site
Disable pop-up blocker	Settings > Advanced > Content Settings > uncheck Block pop-ups
Enable JavaScript	Settings > Advanced > Content Settings > check Enable JavaScript
Enable Cookies	Settings > Advanced > Content Settings > check Accept Cookies
<hr/>	
To...	In the Chrome menu...
Clear browser cache	Settings > Advanced > Privacy > CLEAR BROWSING DATA

To set up and use Safari

NOTES

- The instructions below are for Safari® v11. Other versions may vary slightly. See your web browser's Help if necessary.
- We recommend that you do not run Safari in full-screen mode. If you do, i-Vu® pop-ups will open full-screen, covering the main application window.

On an Apple® computer (Mac®)

Web browser settings	To set in Safari...
Disable pop-up blocker	Preferences > Security > uncheck Block pop-up windows
Enable JavaScript	Preferences > Security > check Enable JavaScript
Enable Plug-ins	Preferences > Security > check Enable plug-ins
Prevent pop-ups from opening in a new browser tab	Preferences > Tabs > uncheck Command-click opens a link in a new tab
Prevent Safari from automatically opening zip files exported from the i-Vu® application	Preferences > General > uncheck Open "safe" files after downloading
<hr/>	
To...	Do the following...
Clear browser cache	History > Clear History
Have 2 different users logged in to the i-Vu® system on the same computer	Start a new web browser session. Select Safari > Private Browsing > File > New window

On an Apple® iPad

Web browser settings	To set on the iPad...
Disable pop-up blocker	Settings > Safari > set Block pop-ups to Off
Enable JavaScript	Settings > Safari > set JavaScript to On
<hr/>	
To...	Do the following...
Clear browser cache	Settings > Safari > Clear History

On an Apple® iPhone 6

Web browser settings	To set on the iPad...
Enable JavaScript	Settings > Safari > Advanced

Getting to know the interface

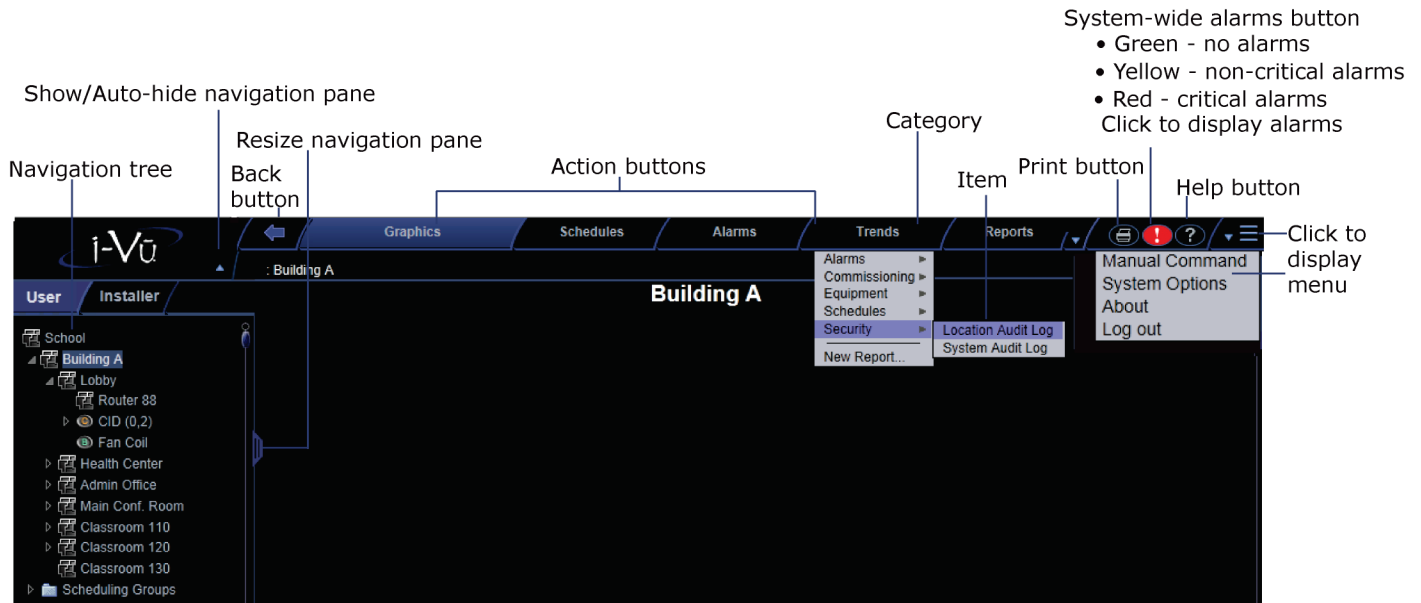

Computer and large-screen mobile interface

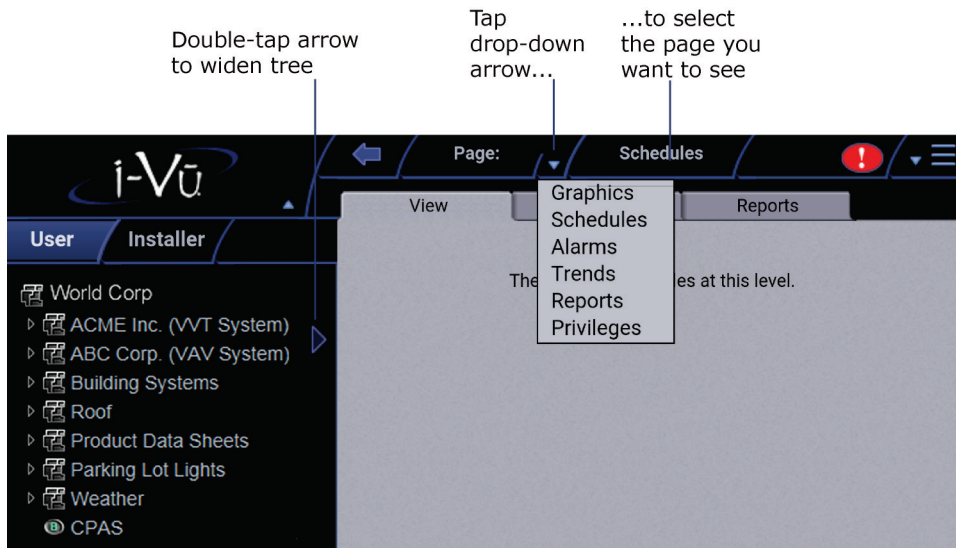

Small-screen mobile interface

Most of the i-Vu® interface is the same on small-screen mobile devices except for the differences shown below.



- When you click  to hide the tree, the button changes to .
- **Help** and **Print** are in the  menu.

NOTES

- After you log in, you will see the page defined as your starting location on the **My Settings** page. To change your opening page, see *To change My Settings* (page 21).
- Roles/privileges control what an operator can see or do in the i-Vu® system. If you cannot see or do something that you read about in Help, ask your System Administrator to check your role/privileges.
- Use only the i-Vu® interface to navigate; do not use the web browser's navigation buttons.
- Click on any tab to refresh the page.

Navigating the system

To navigate in the i-Vu® interface:

- 1 Select the item you want in the navigation tree.
- 2 Select the action buttons and their drop-down lists.
- 3 Use the tabs to filter the information further.

NOTE Use only the i-Vu® interface to navigate; do not use the browser's navigation buttons.

- 4 Click on any tab to refresh the page.

System Options

Click  and select **System Options** (page 20) to view or change the setup and maintenance of your system in your i-Vu® application.

To show, hide, or resize the navigation tree

On a computer or large screen mobile device

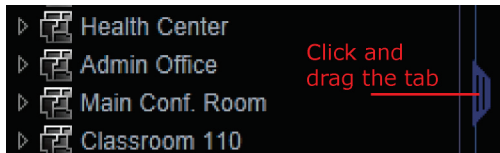

Click  at the top of the navigation tree to hide or show the tree.
Click and drag the tab on the right side of the tree to adjust its width.

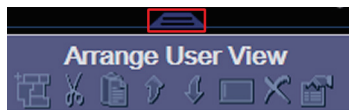

In the **Installer** view, click and drag the tab at the top of **Arrange User View** to adjust the height of the window.



On a small-screen mobile device

Touch  at the top of the navigation tree to hide the tree. Touch  to show it.
Double-tap the arrow on the right side of the tree to widen the tree. Double-tap again to return to the original size.

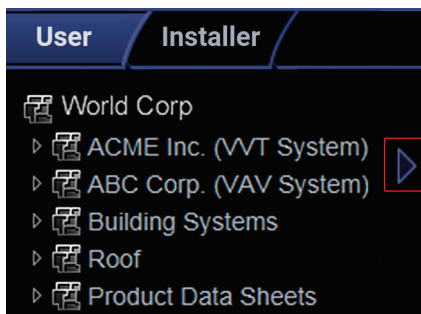

Zooming in and out

On a computer

- To zoom in and out on the i-Vu® interface:
 - Hold down **Ctrl** and press + or -. Press **Ctrl+0** to return to 100%.
 - Hold down **Ctrl** while rolling your mouse wheel.
 - Use your web browser's zoom functions.
- If a graphic does not fit in the action pane, right-click it and select **Scale to Fit** to make it fit the action pane. Select **Scale to Fit** again to return the graphic to its original size.

On a mobile device

Apple® iPad and iPhone

- Double-tap to zoom in/out.

Microsoft® Surface™

- Pinch-zoom works on individual frames, instead of the whole screen. So, you can zoom and scroll the navigation pane and action pane separately.
- If browser text is too small, use **Ctrl +** to increase Internet Explorer's zoom level, then reload the page.

Google™ Nexus™ and Nexus Lumia

- Pinch-zoom to zoom in/out.

Using right-click menus

On a computer

You can right-click the following items to select options:

A tree item

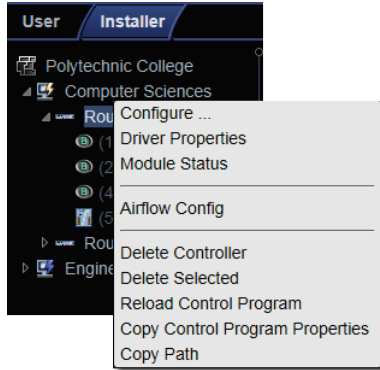

The action pane

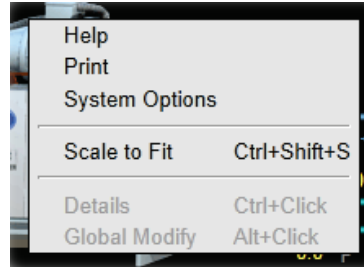

A property

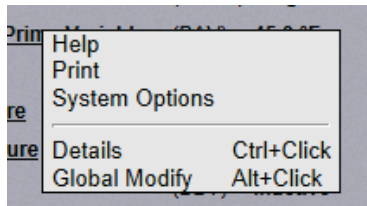

A trend

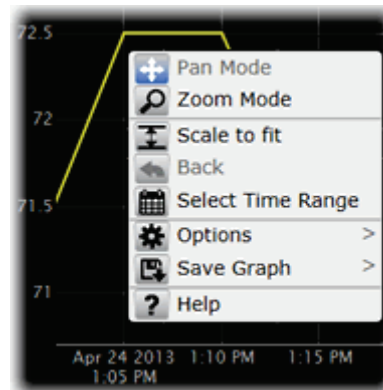

On a mobile device

To access the right-click menu for:

- A tree item–Select the item first, then touch and hold the item for several seconds.
- The action pane–Touch and hold the item for several seconds.

To print the action pane

On a computer

Click  at the top of the page to print the contents of the action pane. Set the print orientation to **Landscape** in the **Print** dialog box.















TIP To print a Graphics page that exceeds the size of the action pane, right-click the graphic and select **Scale to Fit**.

On a mobile device

Touch  and then select **Print**.

Colors and status in the i-Vu® interface

The following colors indicate equipment status throughout i-Vu® interface. These colors are visible on Property pages, Graphics pages and in the setpoint graphs.

Color	Color Name	Status Code	Condition Indicated
	Purple	0 or 15	In a controller—non-operational or no communications In equipment—a hardware or software error
	Charcoal	14	In a controller—a download is required or is already in progress In equipment—a controller has stopped
	Coral	13	Control program error
	Red	2 or 9	Heating or cooling alarm
	Orange	8	Maximum cooling
	Dark blue	3	Maximum heating
	Yellow	7	Moderate cooling
	Light blue	4	Moderate heating
	Grey	1	Unoccupied/inactive
	White	10	Occupied/active
	Light green	6	Free cooling
	Green	5	In a controller—operational or operational read-only In equipment—No heating or cooling









Colors and setpoints

Thermographic colors indicate how much a zone's actual temperature differs from its setpoints.

Five conditions may affect a zone's thermographic color:

- Setpoint adjust
- Timed local override (TLO)
- Optimal start
- Demand level
- Hysteresis

In the examples below, a zone's heating occupied setpoint is 70° and its cooling occupied setpoint is 74°.

If you normally see...	when the zone temp is...	but...	then you will see...
green 	72.5°	someone adjusts the setpoints (for example, with a setpoint adjust of two degrees, the new setpoints would be 68 and 72°)	yellow 
gray 	73° (unoccupied)	someone presses the Override button on a zone sensor to use the occupied setpoints	green 
gray 	77° (unoccupied)	the zone is in optimal start and is ramping up to its occupied setpoint in the few hours before occupancy	an occupied color
yellow 	75°	the zone's electric meter is in demand level 2 with relaxed setpoints of 68 and 76°	green 
green 	73.5°	cooling began when the temperature rose above 74° and the temperature has not yet dropped beyond the 1° hysteresis (to 73°)	yellow 

Using System Options for administrative utilities

Click  and select **System Options** for the following tasks. On the:

- **My Settings** (page 21) tab, change the Installer's:
 - Password
 - Starting view and page
 - Preferences to automatically collapse trees, automatically download schedules on each change, and alarm notification
- **Operators (page 21)** tab, set up:
 - Login names and passwords
 - Logoff rules
 - Starting locations
 - Levels of access (roles)
- **General** (page 25) tab
 - View system statistics - number of devices in the system, number of trends, estimated time for importing or exporting system clipping.
 - Download weekly logs
 - Access the **Management Tool** (page 28)
 - Set system date, time, timezone, and time/date format
 - Enable time synchronization schedule
 - Enable Alarm Notification Client
 - Enable/Disable Schedules feature
 - Import/Export Source Files, which include control programs, drivers, views, screen files, and report design files
 - Enable or disable Full Source download to Open PIC controllers and select to include or not include graphics in download
 - Import/export clipping files
 - Set up the email server
- **Security** (page 30) tab - Set advanced password and operator control
- **Update** (page 31)tab
 - Install .update files
 - Update SAL libraries
 - View current Help updates and current libraries
- **Daylight Saving (page 34)** tab - update scheduled DST dates
- **Add-ons (page 34)** tab - Install add-ons such as Tenant Override Billing or Weather (i-Vu® Plus application only)

NOTES

- Some operators will not see all of the **System Options** tabs, depending on their assigned roles.
- See the i-Vu® Help for more details on the **System Options** tabs.

My Settings tab

To change your settings:

- 1 Click , then select **System Options > My Settings** tab.
- 2 See table below for explanation of settings.
- 3 Click **Accept** or **Apply**.
- 4 Changes become effective when operator logs in again.

Field	Notes
Login	Enable this field, then type your current and new password and confirm. Limit is minimum of 8 and maximum 40 characters of any type.
Starting Location and Starting Page	The i-Vu® location and page that will display after you log in. Select the User or Installer tree, if you have Installer role.
Automatically collapse trees	Expands only one tree branch at a time.
Automatically download schedules on each change	Select to automatically download all new schedules that you create and schedules that you change
Play sound at browser when server receives	The system audibly notifies you when one of the selected alarms is received. Check Non-critical alarms or Critical alarms if you want the system to audibly notify you when that type of alarm is received.

NOTE An operator with the Guest role cannot edit any settings on this page.

Operators tab

Select the necessary settings and assign **Roles** (access rights) to set up operators.

NOTES

- Optimal number of simultaneous users:
 - 2 in the i-Vu® Standard application
 - 10 in the i-Vu® Plus application
- We highly recommended that only 1 user at a time commission the system.

To add or edit operators, passwords, and roles

- 1 Click , then select **System Options**.
- 2 Select **Operators** tab.
- 3 Click **Add** to enter a new operator, or, select an operator to edit his settings.
- 4 Enter information as needed. The required fields are **Name**, **Login Name**, and **Roles**. See table below.
- 5 Click **Accept** or **Apply**.

Field	Notes
Login Name	Must be unique within the system.
Force user to change password at login	Forces the operator to change his password immediately after his next login. NOTE You can combine the use of this field and the Change Password field to create a temporary password that the operator must change after his next login.
Starting Location	Set the starting location for each individual operator by choosing the specific area or controller in the navigation tree and the starting page from the drop-down menu.
Roles	See table below.

This privilege...	allows an operator to...
Installer	<ul style="list-style-type: none"> • Add, edit, and delete operators, operator groups, and privilege sets. • Update the i-Vu® system with service packs and patches. • Register the i-Vu® software. • Enable and set up the <i>advanced password policy</i> (page 31). • Add and remove i-Vu® add-ons.

Access privileges

Guest	Standard User	Power User	Admin	Installer	The following can be accessed but not edited...
<input checked="" type="checkbox"/>	<input checked="" type="checkbox"/>	<input checked="" type="checkbox"/>	<input checked="" type="checkbox"/>	<input checked="" type="checkbox"/>	User tree
	<input checked="" type="checkbox"/>	<input checked="" type="checkbox"/>	<input checked="" type="checkbox"/>	<input checked="" type="checkbox"/>	Control program tables and Properties pages
	<input checked="" type="checkbox"/>	<input checked="" type="checkbox"/>	<input checked="" type="checkbox"/>	<input checked="" type="checkbox"/>	Scheduling Groups pages in the User view navigation tree
		<input checked="" type="checkbox"/>	<input checked="" type="checkbox"/>	<input checked="" type="checkbox"/>	System Options Items
<input checked="" type="checkbox"/>	<input checked="" type="checkbox"/>	<input checked="" type="checkbox"/>	<input checked="" type="checkbox"/>	<input checked="" type="checkbox"/>	Alarms
				<input checked="" type="checkbox"/>	Logic Pages

Functional privileges

Guest	Standard User	Power User	Admin	Installer	The following allows an operator to...
		<input checked="" type="checkbox"/>	<input checked="" type="checkbox"/>	<input checked="" type="checkbox"/>	Manage Alarm Messages and Actions - add, edit, and delete alarm messages and actions.
			<input checked="" type="checkbox"/>	<input checked="" type="checkbox"/>	Maintain System Parameters - edit all properties on the System Options pages.
	<input checked="" type="checkbox"/>	<input checked="" type="checkbox"/>	<input checked="" type="checkbox"/>	<input checked="" type="checkbox"/>	Maintain Schedules - add, edit, delete, and download schedules.
	<input checked="" type="checkbox"/>	<input checked="" type="checkbox"/>	<input checked="" type="checkbox"/>	<input checked="" type="checkbox"/>	Maintain Schedule Group Members - add, edit, and delete schedule groups.
		<input checked="" type="checkbox"/>	<input checked="" type="checkbox"/>	<input checked="" type="checkbox"/>	Maintain Categories - add, edit, and delete categories.
		<input checked="" type="checkbox"/>	<input checked="" type="checkbox"/>	<input checked="" type="checkbox"/>	Acknowledge Non-Critical Alarms - acknowledge all non-critical alarms.
		<input checked="" type="checkbox"/>	<input checked="" type="checkbox"/>	<input checked="" type="checkbox"/>	Acknowledge Critical Alarms - acknowledge all critical alarms.
		<input checked="" type="checkbox"/>	<input checked="" type="checkbox"/>	<input checked="" type="checkbox"/>	Force Normal Non-Critical Alarms - force non-critical alarms to return to normal.
		<input checked="" type="checkbox"/>	<input checked="" type="checkbox"/>	<input checked="" type="checkbox"/>	Force Normal Critical Alarms - force critical alarms to return to normal.
		<input checked="" type="checkbox"/>	<input checked="" type="checkbox"/>	<input checked="" type="checkbox"/>	Delete Non-Critical Alarms - delete non-critical alarms.
		<input checked="" type="checkbox"/>	<input checked="" type="checkbox"/>	<input checked="" type="checkbox"/>	Delete Critical Alarms - delete critical alarms.
			<input checked="" type="checkbox"/>	<input checked="" type="checkbox"/>	Execute Audit Log Report - run the Location Audit Log and System Audit Log reports.
			<input checked="" type="checkbox"/>	<input checked="" type="checkbox"/>	Download Controllers - mark equipment for download and initiate a download.
			<input checked="" type="checkbox"/>	<input checked="" type="checkbox"/>	System Shutdown - issue the Shutdown manual command that shuts down i-Vu® Server.
				<input checked="" type="checkbox"/>	Access Commissioning Tools: <ul style="list-style-type: none"> • Equipment Checkout • Airflow Configuration • Trend, Report, and Graphic categories that require this privilege • Discovery tool (i-Vu® Plus only)
		<input checked="" type="checkbox"/>	<input checked="" type="checkbox"/>	<input checked="" type="checkbox"/>	Maintain Graphs and Reports - add, edit, and delete trend graphs and reports.
			<input checked="" type="checkbox"/>	<input checked="" type="checkbox"/>	Remote Data Access-SOAP - retrieve i-Vu® data through an Enterprise Data Exchange (SOAP) application. (i-Vu® Plus only)
			<input checked="" type="checkbox"/>	<input checked="" type="checkbox"/>	Manual Commands/Console Operations - access the manual command dialog box and issue basic manual commands.
				<input checked="" type="checkbox"/>	Manual Commands/File IO - execute manual commands that access the server's file system.

Guest	Standard User	Power User	Admin	Installer	The following allows an operator to...
				<input checked="" type="checkbox"/>	Manual Commands/Adv Network - execute manual commands that directly access network communications.
	<input checked="" type="checkbox"/>	<input checked="" type="checkbox"/>	<input checked="" type="checkbox"/>	<input checked="" type="checkbox"/>	Change My Settings - edit preferences on operator's My Settings page.

Parameter privileges

Guest	Standard User	Power User	Admin	Installer	The following allows an operator to edit properties such as...
	<input checked="" type="checkbox"/>	<input checked="" type="checkbox"/>	<input checked="" type="checkbox"/>	<input checked="" type="checkbox"/>	Setpoint Parameters - occupied and unoccupied heating and cooling setpoints
			<input checked="" type="checkbox"/>	<input checked="" type="checkbox"/>	Setpoint Tuning Parameters - demand level setpoint offsets, color band offsets, heating and cooling capacities and design temperatures, color hysteresis, and learning adaptive optimal start capacity adjustment values
		<input checked="" type="checkbox"/>	<input checked="" type="checkbox"/>	<input checked="" type="checkbox"/>	Tuning Parameters - gains, limits, trip points, hysteresis, color bandwidths, design temperatures, and optimal start/stop.
		<input checked="" type="checkbox"/>	<input checked="" type="checkbox"/>	<input checked="" type="checkbox"/>	Manual Override Parameters - locks on input, output, and network point.
		<input checked="" type="checkbox"/>	<input checked="" type="checkbox"/>	<input checked="" type="checkbox"/>	Point Setup Parameters - point number, type, range, and network source and destination
		<input checked="" type="checkbox"/>	<input checked="" type="checkbox"/>	<input checked="" type="checkbox"/>	Restricted Parameters - properties the installer restricted with this privilege
		<input checked="" type="checkbox"/>	<input checked="" type="checkbox"/>	<input checked="" type="checkbox"/>	Category Assignments - Alarm, Graphic, Trend, and Report category assignments
		<input checked="" type="checkbox"/>	<input checked="" type="checkbox"/>	<input checked="" type="checkbox"/>	History Value Reset - elapsed active time and history resets, and runtime hours
		<input checked="" type="checkbox"/>	<input checked="" type="checkbox"/>	<input checked="" type="checkbox"/>	Trend Parameters - enable trend logging, log intervals, and log start/stop time.
		<input checked="" type="checkbox"/>	<input checked="" type="checkbox"/>	<input checked="" type="checkbox"/>	Calibration Parameters - point calibration offsets
		<input checked="" type="checkbox"/>	<input checked="" type="checkbox"/>	<input checked="" type="checkbox"/>	Hardware Controller Parameters - module driver properties
					Critical Configuration - critical properties the installer protected with this privilege
		<input checked="" type="checkbox"/>	<input checked="" type="checkbox"/>	<input checked="" type="checkbox"/>	Area Name - area display names

Guest	Standard User	Power User	Admin	Installer	The following allows an operator to edit properties such as...
		<input checked="" type="checkbox"/>	<input checked="" type="checkbox"/>	<input checked="" type="checkbox"/>	Control Program Name - equipment display names
		<input checked="" type="checkbox"/>	<input checked="" type="checkbox"/>	<input checked="" type="checkbox"/>	Alarm Configuration - enabling/disabling alarms and editing alarm messages, actions, categories, and templates
		<input checked="" type="checkbox"/>	<input checked="" type="checkbox"/>	<input checked="" type="checkbox"/>	Status Display Tables - tables available under Status
		<input checked="" type="checkbox"/>	<input checked="" type="checkbox"/>	<input checked="" type="checkbox"/>	Maintenance Tables - tables available under Maintenance
		<input checked="" type="checkbox"/>	<input checked="" type="checkbox"/>	<input checked="" type="checkbox"/>	User Config Tables - tables available under User Config
				<input checked="" type="checkbox"/>	Service Config Tables - tables available under Service Config
	<input checked="" type="checkbox"/>	<input checked="" type="checkbox"/>	<input checked="" type="checkbox"/>	<input checked="" type="checkbox"/>	Setpoint Tables - tables available under Setpoint
	<input checked="" type="checkbox"/>	<input checked="" type="checkbox"/>	<input checked="" type="checkbox"/>	<input checked="" type="checkbox"/>	Time Schedule data Tables - tables available under Time Schedule

General tab

- 1 Click , then select **System Options > General** tab.
- 2 Enter information on this page as needed.
- 3 Click **OK** or **Apply**.

You can edit or use the following fields and buttons.

Field	Notes
System Statistics	Check to Use metric units for CCN tables and control programs Click to see: <ul style="list-style-type: none"> • Numbers of controllers allowed and present in system • Number of trend sources and samples in the database • Estimated time to import/export clipping
Logs	For troubleshooting, download a zip file that contains a log of system activity. Logs are available for a maximum of 4 weeks.

Field	Notes
Management Tool	<p>Select Management Tool (page 28) button to access the following:</p> <ul style="list-style-type: none"> • Download weekly system logs • View or change system name and IP addresses • Port Configuration • Backup and Restore, Compress Trend Storage • Reset to Factory Defaults • Upgrade System Version • Reboot • NTP Configuration
Time	<p>Time Format</p> <ul style="list-style-type: none"> • 12-hour clock (Example: 4:34 pm) • 24-hour clock (Example: 16:34) • Daylight Saving Time is automatically controlled. To update Daylight Saving begin and end dates, go to System Options > Daylight Saving. • Enable time synchronization of controllers daily at - Automatically synchronizes the time on all equipment to the time on the i-Vu® web server, adjusting for different time zones and Daylight Saving Time. We recommend that you enable this field. <p>CAUTIONS</p> <ul style="list-style-type: none"> ○ To prevent time sync problems when the transition to and from Daylight Saving Time occurs, set the time sync to occur at least 1 hour after the last controller in the system is adjusted for DST. For example, your i-Vu® application and part of your system is in the Eastern Standard Time zone, but you also have controllers in the Pacific Time zone. Your server is adjusted for DST at 2:00 a.m. Eastern Standard Time, but the controllers in the Pacific Time zone are not adjusted until 3 hours later. So you would set the time sync to occur daily at 6:00 a.m. or later. ○ Make sure that your i-Vu®'s time and time zone setting are correct. • Time Sync – Sends a time broadcast to synchronize all controllers in the system with the i-Vu® web server's time.
Alarms	Select the checkbox to enable Alarm Notification functionality. See <i>Alarm Popup</i> (page 73) alarm action.
Disable Schedules	If your system has no need to run schedules, check this box so that the Schedules feature is no longer visible in i-Vu® interface.
Trends	NOTE Configurable for the i-Vu® Plus application only. The i-Vu® Standard application is 7 days.

Field	Notes
Import/Export Source Files	<p>Use to import or export source files in a .zip file that can be imported or exported to/from another i-Vu® or Field Assistant system. Source files include:</p> <ul style="list-style-type: none"> • Control programs (.equipment files only) • Drivers • Graphics (.view files only) • Screen files • BACview® files • Report design files for Equipment Values or Trend Sample reports <p>NOTE If import detects a difference between a database file and an import file with the same name, import does not overwrite the database file. A message lists any file differences so that you can resolve them.</p> <p>See <i>Commissioning equipment using Field Assistant</i> (page 146).</p>
Download	<p>You can increase download speed by checking Optimize download for Open PIC controllers. The full source files are not downloaded into the PIC controllers when this is checked.</p> <p>You can increase download speed by unchecking Include graphics in Open programmable controller download. If you are not changing the graphics, you may not want to include them in every download in order to save time.</p>
Clippings	<ul style="list-style-type: none"> • Navigation tree items including attached control programs, graphics, drivers, and screen files • Trend data • Reports • Alarm categories • Schedules and schedule group membership (including the entire schedule group and schedules, if it does not exist in the target system) • Alarm actions <p>NOTE A clipping containing CCN controllers does not include the CCN tables. When importing a clipping containing CCN devices, you must re-scan the table.</p>
Email Server Configuration	The information in this section is used by the <i>Send email alarm action</i> (page 76) and used to email a <i>Scheduled Report</i> (page 101).
From	Enter a valid address if required by your mailserver.
Mail Host	The mailserver's address. This can be an IP address or a system name, such as mail.mycompany.com.
Mail Host Port	Change this field if using a port other than the default port 25.
Mail Host Security Options	<p>Select the type of security the mailserver uses.</p> <ul style="list-style-type: none"> • Cleartext (SMTP) – Uses the SMTP protocol to send as clear text over TCP/IP • Secure SSL (SMTP with SSL) – Uses SSL, a communication protocol that provides data encryption • Secure TLS (STARTTLS) – Uses TLS, but does not begin encryption until the i-Vu® application issues STARTTLS command

Field	Notes
Specify Mail User for Mail Host Authentication	Select if your mailserver requires a username and password.
Test connection	Click to have i-Vu® try to connect to the email server. A message will appear below this button stating if the connection was successful or if it failed.

Management Tool

You can access **Management Tool** by either:

- Clicking  and selecting **System Options > General tab > Management Tool** button
- Launching your browser and typing your system name followed by **:8080**. For ex.: http://ivu:8080/

NOTE The **Management Tool** is password-protected and can only be accessed by a user with **Installer** role.

System Status

i-Vu is running at: This is used to troubleshoot server or LAN communications.
Click the **Stop Server** button to stop the i-Vu® web server. When stopped, the button changes to **Start Server**. Do NOT close the Management Tool before restarting the server. Click to restart.

Weekly system logs:

- **System** - used for troubleshooting (same as logs available from **System Options > General (page 25)** tab). Logs are available for a maximum of 4 weeks.
- **Kernel** - operating system logs

Addressing



CAUTION If you change the name or the IP address of your system, record the numbers in a secure place.

- **Name** - Controls the name used to access your system from the Internet. Do not use special characters or spaces.
- **Obtain an IP address automatically** - Uncheck this to manually assign addresses for the following:
 - i-Vu Address
 - Subnet Mask
 - Default Gateway
 - DNS Address - IP address of the Domain Name Server
 - Domain - Host name of the domain (i.e. carrier.utc.com)
 - USB Network Type - Read-only field shows either CCN or BACnet types.
 - USB Network Address - IP address of the internal BACnet router or the internal CCN Gateway

i-Vu Port Configuration	Changing these values forces a web server restart. Default values: HTTP: 80 HTTPS: 443
Operation Status	Message showing progress of background operations, such as backup and restore.
Manage Server Data	<ul style="list-style-type: none"> • PC Backup - Saves the entire database zipped into one file to your computer. • PC Restore - Replaces the current server data with a backup from your computer. • USB Backup - Saves the entire database zipped into one file onto a USB inserted into the i-Vu® web server. • USB Restore - Replaces the current server data with a backup from your USB inserted into the i-Vu® web server. • Compress System - Creates more storage space for trend data. • Factory Defaults - Deletes all server data and resets the device to the original factory default values. <p>NOTE Executing this option does not delete configuration data under the Addressing and i-Vu Port Configuration sections of the Management Tool.</p>
Machine Maintenance	<ul style="list-style-type: none"> • Management Version - Apply .update file from here. • Reboot - System restart

Configuring NTP

Network Time Protocol (NTP) is a networking protocol for clock synchronization. You can designate an NTP source that sends the correct time to the i-Vu® web server, ensuring constant accurate time. You can enter 2 static addresses (DNS name or IP) of NTP servers or use the default addresses provided by the i-Vu® application. If you do not enable NTP, the i-Vu® system clock must be monitored and updated regularly in **System Options > General** tab.

You can configure DHCP servers to supply IP addresses of NTP servers to the i-Vu® web server. If you have checked **Obtain an IP address automatically** and **Enable Time Synchronization**, the i-Vu® web server tries to obtain an NTP server address from the DHCP server on site. If it cannot find one, the i-Vu® web server uses the User Assigned NTP addresses, if any, in the User Assigned fields.



CAUTION Contact your Network Administrator for guidance in entering these settings.

You can access NTP from a local server, a remote server, or a website. To set up NTP:

- 1 Verify that **Enable time synchronization from an NTP server** is checked.
- 2 **System Assigned NTP Server Address** - To use this read-only field, make sure you have checked **Obtain an IP address automatically** to allow your system to search for an address for the NTP server and display a primary and alternate address.
- 3 **User Assigned NTP Server Address** - You can use the default website addresses if your system allows it. Firewalls may prevent successful access to the default websites. Your Network Administrator can provide alternate addresses for a local server, a remote server, or a website.

Security tab

To adjust security settings,

- 1 Click , then select **System Options > Security** tab.
- 2 Enter information as needed. See table below.
- 3 Click **OK** or **Apply**.

Field	Notes
Return operators to previous locations when server reconnects.	Returns operators to current navigation tree locations when the server reconnects.
Log off operators after __:__(HH:MM) of inactivity	<p>The system automatically logs off an operator who has had no activity in the system for the time period specified.</p> <p>This is a default setting for the system. The Installer or Administrator can change this setting for an individual operator on the <i>Operators</i> (page 21) tab.</p>
Lock out operators after __ minutes after __ failed login attempts	<p>Set the time that a user will be locked out of the system after the failed number of login attempts has been reached.</p> <p>NOTE Restarting the i-Vu® application removes lockouts.</p>
Clear Lockouts	Remove lockouts for all users.
Use advanced password policy	You can place specific requirements on passwords to increase security. See <i>Advanced password policy</i> (page 31).
Permissions	
Permissions	<p>When control programs, views, touchscreen, and BACview® files are created by an original equipment manufacturer (OEM), they cannot be used in the i-Vu® system without the creator's permission. However, the creator can produce a key for a system with a different license that will grant permission to the key's recipient.</p> <p>If you receive a key, put it in a convenient location on your computer. To activate a key, click Add, then browse to the key.</p> <p>To delete a key from your system, select the key in the table, then click Delete.</p> <p>Red text in the table indicates the key has a problem such as it does not apply or has expired. See the Notes column for an explanation.</p>

Advanced password policy

You can set up a password policy to meet your security needs.

- 1 On the **System Options** tree, select the **Security** tab.
- 2 Enter information in the fields described below.

Field	Notes
Use advanced password policy	Enable this field to put restrictions on passwords. An operator's login name and password must be different when this policy is enabled. After you change the password policy, any operator whose password doesn't meet the new requirements will not be locked out of the system, but will be prompted to create a new password.
Passwords must contain	You can specify how many characters and which of the following types of characters a password must contain: <ul style="list-style-type: none">• Numbers• Special characters—any keyboard character that is not a number or letter.• Letters—uppercase, lowercase, or both.
Cannot be changed more than once every __ days.	Enter a number to limit how often users can change their passwords. When set to 0, users can change them as often as they want.
May not be reused until __ different passwords are used.	Enter a number between 1 and 20. Enter 0 to reuse passwords without a delay.
Expire after __ days	Enable to set the number of days an operator can use his password before the system requires him to change it. Enter a number between 1 and 999.
Force expiration	Click this button to force every user's password to expire. Each user will be prompted to change their password when they next attempt to log in to the i-Vu® interface.

Update tab

Select the **Update** tab to install .update files (patches, service packs, drivers, language packs, graphics libraries, and help updates).

Click  next to **Applied Updates** and **Current Libraries** to view all currently applied updates and .SAL files currently and verify if the i-Vu® application has the latest updates or library files.

i-Vu® Library

The i-Vu® application is equipped with a complete library. There are occasionally library (.sal file) updates, which contain the following files:

- graphic (.view)
- control program (.equipment)
- driver (.driver)
- screen (.touch or .bacview)

NOTES

- Get the latest updates from your Carrier representative.
- The library update only changes default graphics. If you have edited your graphic in ViewBuilder, it is not updated.
- Keep copies of the latest libraries in a safe place. In the event of a system restore, any updated .sal files must be reapplied.
- The last digits in the sal library name are the release date of the library.

Step 1: Update library

1 Save the updated library (.sal file) to your computer.

2 Click , then select **System Options > Update** tab.

NOTE Expand **Current Libraries (.sal)** to see the current SAL libraries and their revision. Compare them to what you downloaded from the *Control Systems Support* (<http://www.hvacpartners.com>) to determine if any of them have been updated.

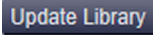
3 Click  and browse to the updated .sal file that you have saved on your computer, select the file, and click **Open**.

4 Click **Continue**.

5 When process is complete, the message appears **File added successfully**.

6 Click **Close**.

NOTE These changes are not applied to the controllers until you have updated routers and controllers.

Follow these steps to implement the new equipment library:

Step 2: Update the files for the routers

1 Select the router that you wish to update in the navigation tree.

2 Right-click and select **Driver Properties**.

3 Select **Properties** page > **Update** tab.

4 If the database contains two or more routers, you must check **Change for all controllers of this type?** in the **Controller** section.

- 5 Click **Update**. A message appears **Changes the driver and screen file to use the current library version. Continue?**

NOTE If more than one router exists, the additional routers are listed below the **Update** button.

- 6 Click **OK**.
- 7 Click **Accept**.

Step 3: Update the files for Open controllers

- 1 Double-click the controller in the navigation tree or right-click and select **Configure**.
- 2 If you have multiple controllers of the same type, enable **Change for all control programs of this type?**
- 3 Click **Update** under **Control Program**. A message appears **Changes the control program, view, driver, and screen file to use the current library version. Continue?**
- 4 Click **OK**. When the message **Updated to the library version xx.** appears, click **Close**.
- 5 Repeat steps 1 - 4 for any additional types of controllers.
- 6 Click **Close** again.

Step 4: Update the files for CCN controllers

- 1 In the navigation tree, select the CCN device manager associated with the controllers that are to be updated.
- 2 Select **Devices > CCN Discovery** and re-scan any controllers that need to be updated by checking **Rescan Controllers Selected Below for Configuration Changes** and clicking **Start Scan**.

Step 5: Apply the update to the routers and controllers

- 1 Select the site level in the navigation tree and then select the **Downloads** page.
- 2 If you wish to apply the new SAL file to your entire system, you can use this page to compare to your navigation tree and verify that you have selected all of your routers and controllers for download.
NOTE Only the CCN Gateway and device managers require download, so the CCN controllers/equipment will not be listed.
- 3 A network's controllers download in the order shown. To change the order, select a controller(s), then drag and drop or click **Move to Top** or **Move to Bottom**.
EXCEPTION If a controller's router requires a download, it will download first regardless of its position on the Download page. Click the **Start** button.

NOTES

- Use **Ctrl+click**, **Shift+click**, or the **Select All** checkbox to select multiple controllers.
 - Up to 5 routers can download simultaneously.
- 4 See *To download from the Downloads page* (page 150) in Help for more details.

Daylight Saving tab

On this tab, you can adjust the Daylight Saving Time settings.

Click **Update** to automatically set the table's **Begin** and **End** dates for the next 10 years based on the system's timezone. This marks all controllers for a Parameters download.

If the updated dates are incorrect

If you clicked **Update** but the dates are incorrect, your system's Java timezone data may be out-of-date. Do the following:

- 1 Go to the *Oracle Java SE Download site* (<http://java.sun.com/javase/downloads>).
- 2 Download the **JDK DST Timezone Update Tool (tzupdater-version.zip)**.
- 3 In the i-Vu® interface, click , then select **System Options > Daylight Saving** and then click **Import**.
- 4 Browse to the **tzupdater.zip** file, select it, then click **Open**.
- 5 Click **Continue**.
- 6 Restart the i-Vu® application.
- 7 On the **System Options > Daylight Saving** tab, click **Update**.

Add-ons tab

The i-Vu® Plus application supports add-ons, such as Tenant Override Billing or Weather, that retrieve and use i-Vu® data. As of v7.0, the i-Vu® Plus application allows only add-ons that are supported by Carrier.

To install an add-on

- 1 Save the add-on's file (.addon or .war) to your computer.
- 2 Click , then select **System Options > Add-ons** tab, and browse to the file.
- 3 Click **Install Add-on**. After a few seconds, the add-on will appear in the **Installed** table, and will be enabled. The table below gives a description of each column.

Column	Notes
Name	The add-on's name.
Path	To open the add-on in a web browser, append this path to your i-Vu® system's address. For example, to start Tenant Billing, type <code>http://<system_name>/override</code> , or <code>http://<system_IP_address>/override</code>
Version	The version is shown if the author provided the information in the add-on.

Column	Notes
Status	<p>If this column shows:</p> <ul style="list-style-type: none"> ○ Running, you can open the add-on in a web browser. ○ Disabled, click Enable to run the add-on. ○ Startup error, select the table row to see an explanation of the error under Details.

- 4 Select an add-on in the **Installed** table to disable or enable it, or to see the following **Details**.

Add-on main page	Click the main page link to open the add-on, if the author provided a main page.
Description	A description of the add-on, if the author provided one
Vendor Name	The add-on's author
Public Data Directory	This public directory contains data generated by the add-on. This data is visible in a web browser.
Private Data Directory	This private directory contains information such as configuration data.

To back up the add-on's private and public data directories

NOTE This procedure will not back up data stored in an external database.

- 1 Select the add-on in the table.
- 2 Click **Save Data**.
- 3 Click **OK**.
- 4 Click **Save**.
- 5 Select the location where you want to save the data, then click **Save**.

To update an add-on

NOTE Add-ons for i-Vu® v6.0 and later systems have a different folder structure than previous versions.

- 1 Select the add-on in the table.
- 2 Click **Remove Add-on and Keep Data**
- 3 Follow the procedure above to install the new version of the add-on.

To uninstall an add-on

- 1 Select the add-on in the table.
- 2 Click **Remove Add-on and Data**.

Working with equipment in the interface

You can view and adjust equipment operation from the following pages:

Devices pages

Select the system level on the navigation tree to view the Devices page, where you can:

- Upload source files or just parameters
- Download source files, schedules, parameters, or BBMD tables
- Check status and error messages
- View model, IP address, drivers, device ID
- Edit device names



Graphics pages (page 38)

You can view and adjust your essential building controls on most Graphics pages.

Equipment drawings show the current status of mechanical equipment.

Adjust **setpoints** (page 52) on a Graphics page.

To upload a graphic from ViewBuilder, double-click the controller in the navigation tree or right-click and select **Configure**.

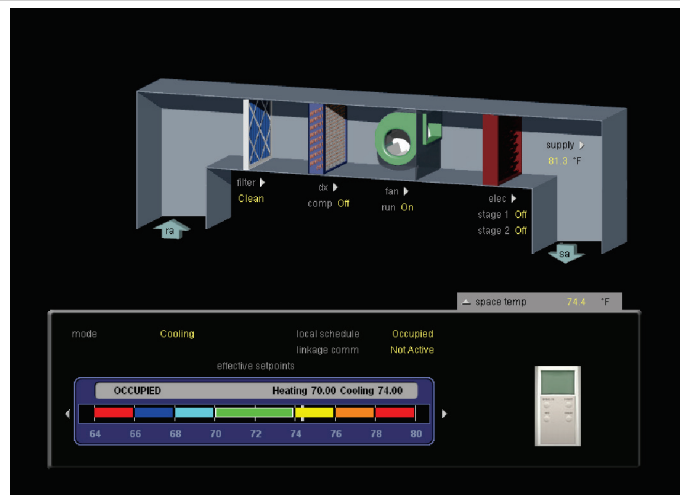

Logic pages (page 42)

Logic pages show the control program for a piece of equipment. Use the sequence of control and yellow status values on the Logic pages for troubleshooting your mechanical equipment.

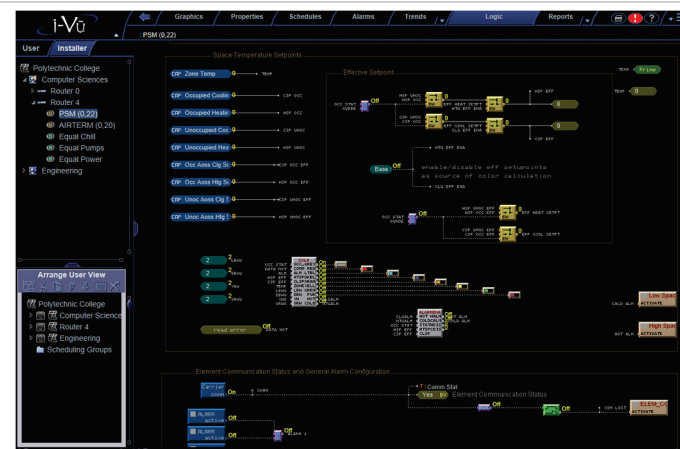

Properties pages (page 41)

You can monitor and control point sources.

- 1 Select the equipment in the navigation tree.
- 2 Click **Properties** page > **Control Program** tab.
- 3 Expand the plus sign next to the desired table.

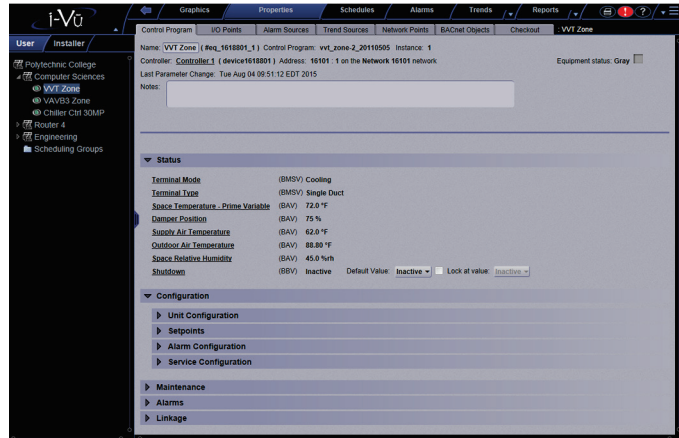

Properties/Microblock popups

Click a property or point to open the microblock popup to view and change details, including forcing or locking values.

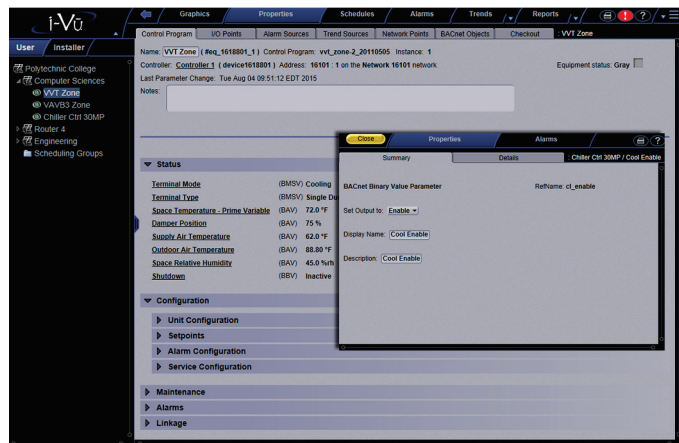

Graphics pages

You can view and adjust your system from Graphics pages, which include navigation maps, floor plans, and equipment.



Some typical controls that may appear on a graphics page are:

- Button or switch to turn equipment on or off
- Input field to set a property value
- Drop-down list to select a state
- Interactive zone sensor to override an unoccupied schedule
- Setpoint graph to adjust setpoints
- Trend graph to view trend information
- Link to jump to another i-Vu® page or to the Internet

NOTES

- Right-click a value, then select **Details** to view and change properties in the microblock pop-up.
- Right-click a value, then select **Global Modify** (page 44) to view and change the property in other control programs.
- A yellow dashed box around a value indicates the value is locked or forced. 
- If a graphic does not fit in the action pane, right-click it and select **Scale to Fit** to make it fit the action pane. Select **Scale to Fit** again to return the graphic to its original size.
- When a chart that is based on a report is displayed on a Graphics page, you can hover over various points on the chart to see values. You can also click on each item in the legend to turn that information on and off. See *Custom report as the source for a Graphics page* (page 100).

To attach a graphic in the i-Vu® interface

- 1 On the navigation tree, right-click the item that you want to attach a graphic to, then select **Configure**.
- 2 Do one of the following:

If the graphic is...

In the Graphic Page drop-down list	a. Select the graphic. b. Click Accept .
Not in the Graphic Page list	a. Click Add New . b. Browse to select the view file. c. Click Open . d. Click Continue . e. Click Close . f. Click Close again.

NOTE You can click **Delete Unused** at the bottom of the **Views** section to delete all unattached graphic files from your system.

- 3 Equipment graphic only: If the system has other control programs of this type, select which control programs you want to change.

- Change this control program only.
- Change for all control programs of this type on this network only.
- Change for all control programs of this type.

NOTES

- o If the control program is in an IP router, the second option will change the graphic for all control programs of this type only on the IP network.
- o If the control program is on the network below an IP router, the second option will not change the graphic for the router's control programs of this type.



To edit a graphic from the i-Vu® application in ViewBuilder

- 1 In the i-Vu® interface, double-click the controller in the navigation tree or right-click and select **Configure**.
- 2 Click **Edit Existing** button under **Views**.
- 3 Click **Save as** and place the file in an appropriate folder.
- 4 Open ViewBuilder.
- 5 Select **File > Open**. Browse to your saved graphic and click to open.
- 6 Edit and save with a new name - the original system name is locked and cannot be used for an edited graphic.

NOTE Names are case sensitive and should not have spaces and/or special characters.

To control equipment using an interactive zone sensor

An equipment graphic may include an interactive zone sensor that provides you with the following control.

If the sensor is a...	You can...
<p>ZS</p>  The ZS sensor is a rectangular white device with a green LCD screen at the top showing '75°F'. Below the screen is a small green LED indicator. At the bottom, there are two buttons: a power button on the left labeled 'OVR' and a directional pad on the right with up and down arrows.	<ul style="list-style-type: none">• Click ▲ to raise the setpoint or ▼ to lower the setpoint.• Click ⏻ to override the schedule and put the zone in an occupied state. To cancel an override, continue clicking ⏻ until the display shows 0.• See that the zone is in an occupied state when the green LED is lit.
<p>SPT Standard, Plus, or Pro</p>  The SPT sensor is a rectangular white device with a green LCD screen at the top showing '75°F' and 'Unoccupied' below it. Below the screen are four buttons: 'MANUAL' (top left), 'WARMER' (top right), 'INFO' (bottom left), and 'COOLER' (bottom right).	<ul style="list-style-type: none">• Click the WARMER or COOLER button to adjust the setpoint.• Click the MANUAL button to override the schedule and put the zone in an occupied state.• Click the INFO button to cycle through the following information:<ul style="list-style-type: none">• Outside air temperature, if enabled in the control program• Override time remaining• Heating setpoint• Cooling setpoint• See the Occupied/Unoccupied state in the display.
<p>SPT Pro Plus</p>  The SPT Pro Plus sensor is a rectangular white device with a green LCD screen at the top showing '75°F' and 'Occupied' below it. Below the screen are six buttons: 'MANUAL' (top left), 'WARMER' (top right), 'INFO' (middle left), 'COOLER' (middle right), 'MODE' (bottom left), and 'FAN' (bottom right).	<ul style="list-style-type: none">• Click the WARMER or COOLER button to adjust the setpoint.• Click the MANUAL button to override the schedule and put the zone in an occupied state.• Click the INFO button to cycle through information such as:<ul style="list-style-type: none">• Outside air temperature• Override time remaining• Heating setpoint• Cooling setpoint• Click the FAN button to adjust the fan speed.• Click the MODE button to perform customer-specific functions.• See the Occupied/Unoccupied state in the display.

Properties pages

Properties pages are automatically generated from control programs. **Properties** pages show the status of a piece of equipment and the points/properties currently stored in it. See *Check out point setup* (page 138) for details.

Use **Properties** pages to:

- View the status of a piece of equipment. See *Colors and status in the i-Vu® interface* (page 18).
- View or change the equipment point/properties currently stored in the controller.
- *Commission equipment* (page 138)
- Set up Linkage.

Refer to your individual controller's *Installation and Start-up Guide* for detailed explanations of the points/properties.

To view or edit properties on a Properties page

- 1 Select a controller on the navigation tree, click **Properties**, and then select the appropriate tab.

NOTE You must resolve any condition described in red text at the top of the page before a **Properties** page can obtain current information from its controller.

- 2 Click  to show property details.

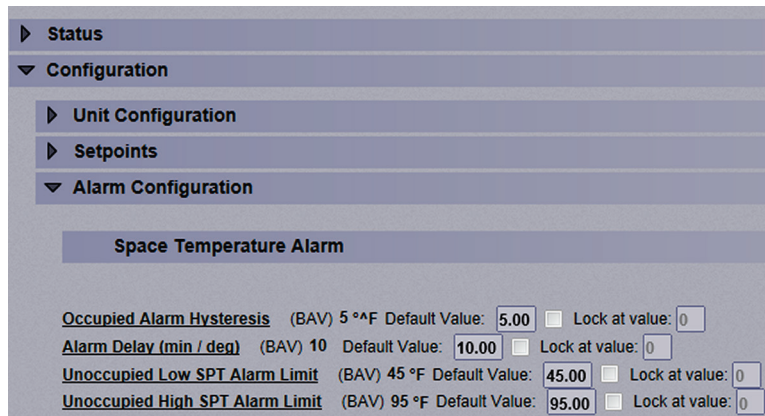

Property Name	Value	Default Value	Lock at value
Occupied Alarm Hysteresis (BAV) 5 °F	5.00	5.00	<input type="checkbox"/>
Alarm Delay (min / deg) (BAV) 10	10.00	10.00	<input type="checkbox"/>
Unoccupied Low SPT Alarm Limit (BAV) 45 °F	45.00	45.00	<input type="checkbox"/>
Unoccupied High SPT Alarm Limit (BAV) 95 °F	95.00	95.00	<input type="checkbox"/>

- 3 Do one of the following to change a property:
 - Select or clear a checkbox
 - Select an item on a drop-down list
 - Change text in a text field
- 4 Click **Accept**.

NOTES

- Click the bold, underlined point name to open the editable microblock pop-up
- Right-click a value, then select **Details** to view and change properties in the microblock pop-up.
- Right-click a value, then select **Global Modify** (page 44) to view and change the property in other control programs.
- Use **Search/Replace** on the **Network Points** tab to replace a term in the point address with another address.
- For the legend of status colors, see *Colors and status in the i-Vu® interface* (page 18).
- A yellow dashed box around a value indicates the value is locked or forced.

Logic pages

The **Logic** page shows a custom control program for a programmable controller. The live data (yellow text) is updated every few seconds and when you click the **Logic** button. The control program uses exact property values for its calculations, but values are rounded to 2 decimal places when displayed on the **Logic** page.



TIP Click anywhere on the **Logic** page, then use your keyboard's Page Up, Page Down, and arrow keys to scroll through the page.

NOTE If you find an unexpected value on a **Properties** page or a **Logic** page, you can use the **Logic** page to troubleshoot.

To view a Logic page

- 1 Select a custom control program on the navigation tree.
- 2 Click **Logic**.
- 3 Click a microblock to view its details.

To locate a microblock, section, or label

- 1 Right-click the Logic page, then select **Jump To**.
- 2 Do one of the following:
 - On the **Microblock** or **Section** tab, select an item to have it located and highlighted.
 - On the **Label** tab, select a label to display a reduced logic page outlined in yellow that shows all instances of the label. A red box indicates an output label; a yellow box indicates an input label. Click a red or yellow box to jump to that label in the full-size logic page.

NOTE You can also click a label on the full-size Logic page to display the reduced Logic page.

To change properties, alarms, or trends

- 1 Click a microblock on the equipment's **Logic** page.
- 2 In the microblock pop-up, click the **Properties, Alarms, or Trends** button.
- 3 Change properties, alarms, or trends for that microblock in the same way that you would make changes on a regular *Properties* (page 41), *Alarms* (page 79), or *Trends* (page 89) page.
- 4 Click **Accept**.

NOTE Right-click a value, then select **Global Modify** (page 44) to view and change the property in other control programs.

Using a Logic page to troubleshoot

The i-Vu® application monitors your system and provides feedback. If you get unexpected feedback, you can use a Logic page as a troubleshooting tool. On the Logic page, work your way backward (right to left) through the sequence in the control program to discover what caused the problem. See Microblock Reference to understand what each microblock in the sequence is doing.

Unexpected feedback	Possible cause
Space temperature reads excessively high or low	<ul style="list-style-type: none"> • The sensor has a short (or open) circuit. Verify wires are properly connected at the sensor and controller. • A sensor is missing or configured incorrectly. Open the sensor or input microblock from the Logic page to verify its configuration.
Equipment displays an unexpected color - effective setpoints are different than the programmed setpoints	<p>NOTE Equipment operates using effective setpoints. Open the Setpoint microblock from the Logic page and check the following:</p> <ul style="list-style-type: none"> • Hysteresis • Demand Level • Optimal Start • Timed Local Override (TLO) • Setpoint Adjust
Gaps in trend data on trend graph	<p>Usually gaps result if network communication was disrupted or a point was temporarily disabled.</p> <p>If the gap is not the result of interrupted communication, send reports more frequently. From the Logic page, open the trend microblock that displayed the gap in data, then decrease the notification threshold so that it is approximately 40% of the buffer size (allocated memory size) for that microblock.</p>
The i-Vu® application is not receiving alarms from a BACnet alarm microblock	<p>Locate the microblock on the Logic page. If the color square on the microblock is black, the alarm is disabled. To enable it:</p> <ol style="list-style-type: none"> 1 Click the microblock. 2 In the microblock pop-up, click the Alarms button. 3 On the Enable/Disable tab, select Potential alarm source.

Unexpected feedback	Possible cause
The equipment is on when I expect it to be off, or off when I expect it to be on	Use the Logic page to determine whether the program is sending an unexpected signal and why, or if the problem is with the physical equipment. For example, the On-Off-Auto (OOA) switch on the controller for that equipment may be locked in the On (Hand) position.
Sensor value on the Properties page does not match the reading from handheld sensor	Calibrate the sensor. On the Logic page, check to see if the output point is locked on.

Changing multiple microblock properties

Two i-Vu® features, **Global Modify** and **Global Copy**, allow you to view and change multiple microblock properties at the same time.



CAUTION Global Modify and Global Copy are convenient for making widespread changes in your system. But, because they do not take into account the operation of individual equipment, your changes could produce undesired results in your equipment or system operation. Use with caution because these features do not have an Undo function.



TIP Click  to copy a microblock's reference path to the clipboard so you can paste it into another field or application.

To use Global Modify

Use the Global Modify feature to:

- View a microblock's full path, control program name, and the privileges required to change its properties.
- View or change a single property in several control programs at one time.
- View errors on Graphics and Properties pages.

- 1 Browse to any page that displays the property you want to view or change.
- 2 Do one of the following to open Global Modify:
 - **Alt+click** the property.
 - Right-click the property and select **Global Modify**.

- 3 Make changes to the **Control Program** field, if needed.

NOTES

- o Use wildcards in the **Control Program** field to broaden the search.
For example:
 vav* matches vav, vav**1**, vav**x**, vav**12345**
 vav*z matches vavz, vav**1z**, vav**xz**, vav**12345z**
 vav*1*2 matches vav12, vav**abc1xyz2**
 vav?? matches vav**11**, vav**12**, vav**zz**, but does not match vav, vav1, vav123
 * matches any control program
- o Click **Show Advanced** to view the location, value, and privileges associated with this property.

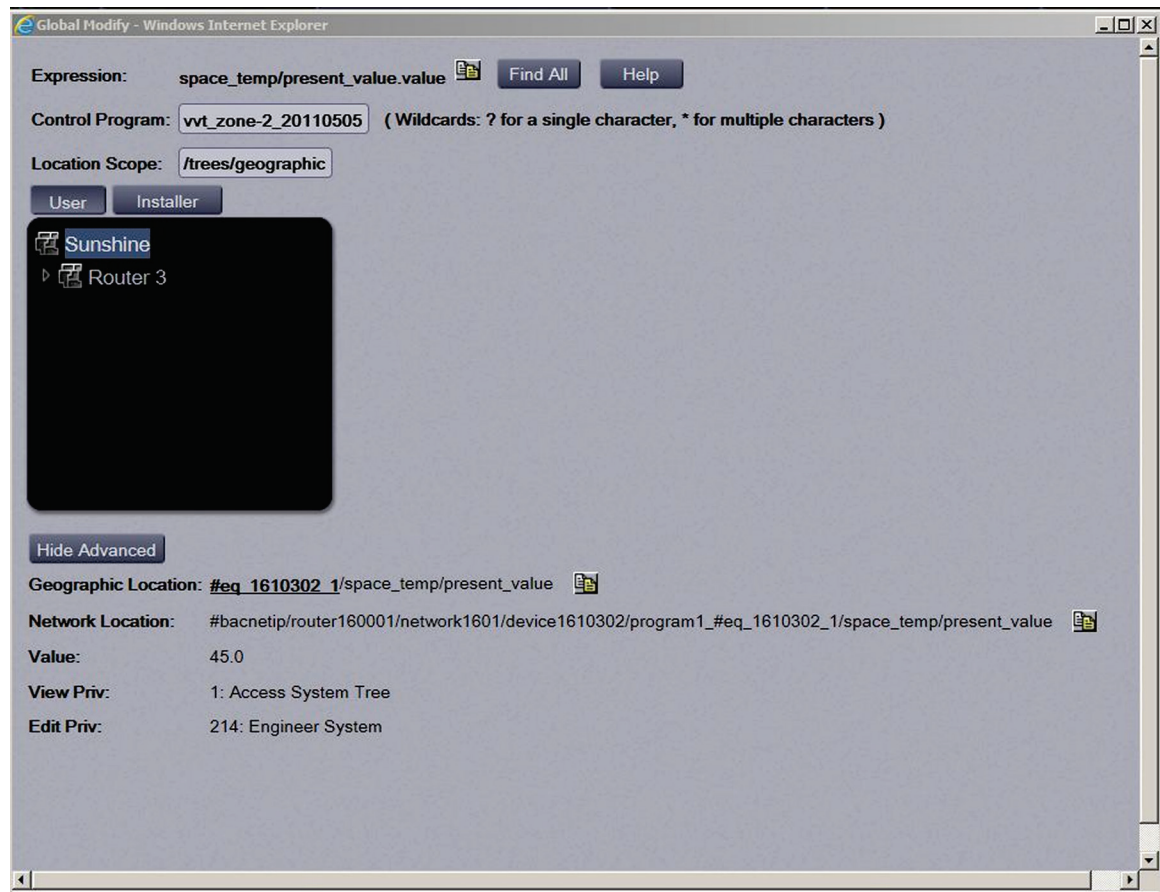

- 4 Select the tree item that you want to search under for every occurrence of that microblock in other control programs.
- 5 Click **Find All**.
- 6 Select the properties in the list that you want to change.

- 7 Do one of the following:
- Type a **New Value** to the right of each selected item.
 - Select **Enable All**, type a new value in **b**, then click **Set All To**.
 - Select **Enable All**, type a new value in **c**, then click **Change All By**.

Enable	Equipment	Current Value	New Value
<input checked="" type="checkbox"/>	Router 3 / VVT Zone	1.00	1.00 a
<input checked="" type="checkbox"/>	Router 3 / VVT Zone	1.00	1.00 a

<input checked="" type="checkbox"/>	Enable All	b 1.00	Set All To
		c ?	Change All By

Apply Changes

- 8 Click **Apply Changes**.

NOTE To modify several properties in multiple control programs at the same time, use **Global Copy**.

To use Global Copy

Use **Global Copy** to copy any or all of the following from one control program to other equipment using the same control program:

- Embedded trend graph settings
- Custom trend graphs
- Custom reports
- Other editable properties to other pieces of equipment using the same control program.

- 1 On the navigation tree, right-click the piece of equipment that has the properties you want to copy, then select **Copy Control Program Properties**.
- 2 Click **OK** when you see **This will copy this control programs properties to other control programs of the same type. Continue?** This opens the next screen and does not lock in any changes.
- 3 In the **Global Copy** dialog box, select the items that you want to copy.



- 4 Select the area on the tree containing similar control programs that you may want to copy these properties to, then click **Search**.
All instances at that level and below are listed in the expanded lower window.
- 5 Check or uncheck items as needed.
- 6 Do one of the following:
 - Check **Skip bad values** to copy all values except a bad value (it cannot be copied because you do not have the necessary privilege, the property to be copied is undefined, etc.).
 - Uncheck this field to prevent any values from being copied if a bad value is found.
- 7 Click **Apply Changes**, then close the **Global Copy** dialog box.







Checking controller status

On the i-Vu® navigation tree, you can select a router or the system level and then click the **Devices** button to:

- *View the status of controllers (page 48)*
- *View controller information such as address, model, driver, and .view files included in download*
- *Download or upload to resolve a mismatch (page 51)*
- *Troubleshoot network communication (page 169)*
- *Download or upload files for Field Assistant (page 146)*

NOTES

- Use **Ctrl+click**, **Shift+click**, or the **Select All** checkbox to select multiple controllers.
- Click **Hold** to stop pending  downloads or uploads. Active downloads  or uploads  cannot be stopped.
- Icons in the **Tasks** column indicate the following:

	Active —The i-Vu® application is downloading to the controller.
	Active —The i-Vu® application is uploading from the controller.
	Pending —You initiated the download, and the controller is waiting for its turn to download.
	Failed —The download failed. See <i>If a controller fails to download (page 151)</i> .
	On Hold —Indicates you clicked Hold to stop a pending  download.

- Click  in the upper left-hand corner to view a log of activity on the **Devices** page in the current session. **Copy to Clipboard** lets you copy the text to paste it into another application.

Status messages

On the i-Vu® navigation tree, you can select a router or the system level and select the **Devices** page to view the status of controllers. The **Status** column shows a description of the controller's current state. Hold your cursor over that description to see hover text with a more detailed description.

If multiple conditions exist, the i-Vu® interface displays the message with the highest priority.

The table below shows all possible messages. The message color indicates the following:

Black—In process

Red—An error occurred

Blue—Requires action from the user

i-Vu® Open routers/controllers

Status column message	Hover text message	Notes
Black messages:		
Downloading	The controller is downloading, communications may be disabled	
Uploading	The controller is uploading, communications may be disabled	
Pending	This controller is waiting to be processed.	
Processing Clipping	Clipping operation in progress. Do not make changes during this operation, as they may corrupt your system.	
Red messages:		
Communications Error	Cannot communicate with this controller.	
Connection Disabled	The connection for this controller has been disabled.	Occurs if someone stopped the connection.
Connection Error	The connection for this controller failed to start.	Occurs if the connection is misconstrues or failed to start.
Controller offline	The controller is offline.	This only appears for equipment controlling slave devices that it is unable to communicate with.
Download Failed	(Message depends on the cause of the failure.)	
Download Not Permitted	This controller is not permitted to download.	
Error	An unknown error has occurred.	
Missing Files	Upload failed. Server is missing the source files.	

Status column message	Hover text message	Notes
Not Uploadable	This controller is not configured for content upload.	Occurs if you attempt to upload a controller with a pre-4.x driver.
Out of Service	This controller is out of service.	
Unsupported Controller	This controller does not support content upload.	
Upload Not Permitted	This controller is not permitted to upload.	
USB Unplugged	Cannot communicate with the controller because the USB cable is unplugged.	Applies only to the i-Vu® Standard and Plus applications.
Blue messages:		
Controller Replaced	This controller has been replaced by another controller of the same type in the field.	4.x driver only
Download All Content	Please download all content to the controller.	
Download Parameters	To download parameters, highlight row and select Parameters from the Download Action menu and click Download .	
Download Schedule	To download schedules, highlight row and select Schedules from the Download Action menu and click Download .	
Driver Parameter Mismatch	Driver parameter differences detected. Upload parameters from the controller or download parameters to the controller.	
Network Ready for Upload	To upload this network, select the router in the tree and Find Devices .	
Parameter Mismatch	Control program parameter differences detected. Upload parameters from the controller or download parameters to the controller.	
Program Mismatch	Content differences detected. Upload all content from the controller or download all content to the controller.	4.x driver only
Unprogrammed Controller	Applies only to a programmable controller that does not have any control programs in it.	To add control programs, click Add Control Program .
Upload All Content	Please upload all content from the controller.	
General messages:		
	This controller is ok.	

Status column message	Hover text message	Notes
Cancelled	The last operation on this controller was cancelled	

CCN controllers/equipment

Status column message	Hover text message	Notes
<blank>	This is a known control program from a previous discovery, but communications with it has not been attempted since the user logged in.	
	Successful rescan.	
Downloading	Downloading changes. Communications will resume shortly.	
New Control Program	A new controller was found at the scanned address and added to the system.	
New Version Applied	This controller's program or views have been updated with a newer version.	

Red messages:

Communications Error	Cannot communicate with this controller.	
Download Failed	<The message is specific to the failure.>	
USB Unplugged	Cannot communicate with the controller because the USB cable is unplugged.	Applies only to the i-Vu® Standard and Plus applications.

Blue messages

Classification Mismatch	The controller at this address was previously a Bridge routing to other controllers.	
Download All Content	Please download all content to the controller.	
Model Mismatch	The controller at this address is the wrong model.	
Rescan Required	A configuration change was made to this control program therefore a rescan is required to get the correct graphic and control logic components.	

Handling parameter mismatches

A parameter mismatch occurs when a value in a controller does not match the value in the system database. This can be a driver or control program value.

To find mismatches in your system

You can find mismatches in the following places:

- The **Devices** page > **Manage** tab > **Status** column will show **Parameter Mismatch**.
- The **Properties** page for a controller, driver, control program, or point will show one of the following red messages at the top of the page stating:

Control Program parameter differences detected.

Driver parameter differences detected.

Parameter download required.

The value that has a discrepancy will appear with a purple box around it. Hover your cursor over the field to see:

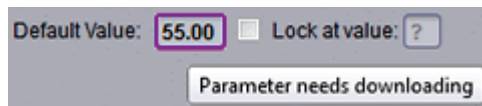

or



- Go to **Reports > Equipment > Parameter Mismatch**, and then click **Run** to get a report of any existing mismatches in your system.

NOTE The **Downloads** page > **Tasks** column will show **Resolve Parameters** for any mismatches that your system discovered in the 3 places listed above.

To resolve a mismatch

1 Go to one of the following:

- **Devices** page - Click the **Parameter Mismatch** link
- **Properties** page that shows one of the red messages above

2 Click one of the following:

- **Resolve** to let the i-Vu® application download changes made in the i-Vu® interface or upload changes made in the controller. Click the **Details** button to see what the discrepancy is and whether **Resolve** will download or upload parameters. See NOTE below.

Differences between controller and database values for Network 16101 /

Controller 1 / VVT Zone:

Last Database Change : 8/4/2015 9:24 AM
 Last Controller Change : 6/5/2014 9:58 AM
 Last Resolve : 6/5/2014 9:58 AM

Expression	Database	Resolve	Controller
max_sprh_ovr/relinquish_default	55.0	→ ←	60.0
stpt_adj_enable/locked	true	← →	false
stpt_adj_enable/locked_value	1	← →	0

Download
Upload

- **Upload** to upload the parameters from the controller to the i-Vu® application
- **Download** to download the parameters from the i-Vu® application to the controller

NOTE On the **Devices** page with **Show Control Programs** unchecked, if a controller has simultaneous mismatches in the driver and control program, clicking **Details** will show that a control program mismatch exists but it will only show details for the driver mismatch. You must go to the control program in the tree to see details of that mismatch. However, clicking **Resolve** will resolve both mismatches.

Managing setpoints

The **Setpoint** graphic shown on a standard equipment graphic indicates the base setpoint values (Occupied High/Low, Unoccupied High/Low). The i-Vu® application reads these values back periodically, typically within 10 seconds. The timing can vary based on network traffic, the number of controllers in the database, and several other variables. Setpoints that are changed in the field via another user interface are displayed in the i-Vu® interface as soon as they are detected.





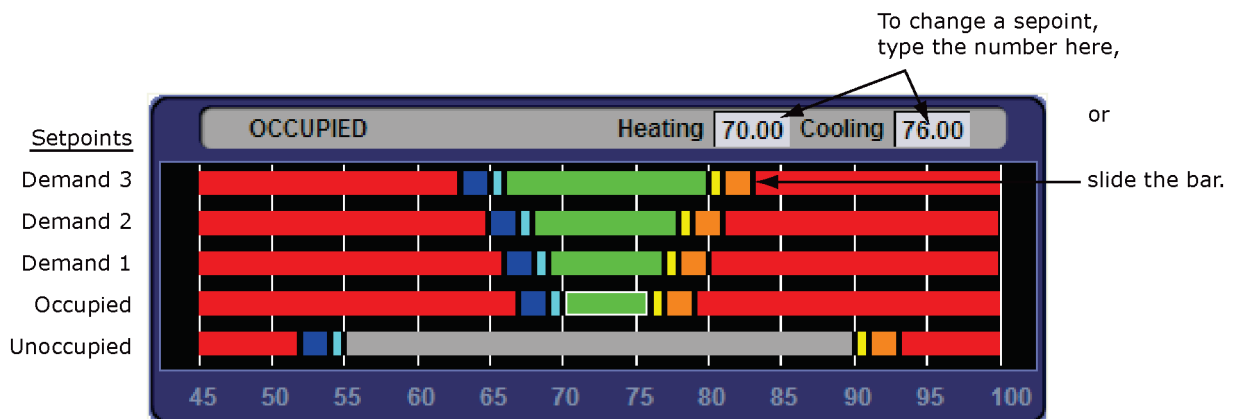

You can, at any time, change the setpoints from i-Vu® graphics by using the slider or by entering numeric values directly. Updated setpoints are transmitted to the controller when you **Accept** the changes. Setpoints can also be changed on the **Properties** page > **Control Program** tab > **Space Temperature and Setpoints**. or **Configuration** > **Setpoints**.

NOTE Power and Standard operators may only edit **Occupied/Unoccupied** and **Heating/Cooling** setpoints. They cannot edit **Demand** levels or more detailed setpoint parameters.

The various color bars indicate adherence to or deviation from the setpoint. You can change the current default settings for setpoint deviation. Select a color band on the setpoint graph to see the current setpoints in the **Heating** and **Cooling** fields. The values in this graphic are Fahrenheit. See setpoint descriptions below.

NOTE This graphic is an example only. Your setpoints may differ.



Color	Condition
	Green Temperature is within the Occupied Low and High Setpoint
	Grey Temperature is within the Unoccupied Low and High Setpoint
	Light Blue Temperature is less than 2°F below the Occupied Low Setpoint
	Dark Blue Temperature is more than 2°F below the effective Low Setpoint but less than 4°F below the effective Low Setpoint
	Yellow Temperature is less than 2°F above the effective High Setpoint
	Orange Temperature is more than 2°F above the effective High Setpoint but less than 4°F above the effective High Setpoint
	Red Temperature is more than 4°F above or below the effective setpoints

VVT Zone 3

damper ▶ 97 %

supply ▶ 62.0 °F

elec ▶ stage 1 Off stage 2 Off

valve ▶ 0 %

space temp 72.0 °F

terminal mode 4 = VENT local schedule Occupied linkage mode 8 = VENT linkage comm Active

effective setpoints

OCCUPIED Heating 70.00 Cooling 74.00

66 68 70 72 74 76 78

terminal mode 4 = VENT local schedule Occupied linkage mode 8 = VENT linkage comm Active

OCCUPIED Heating 70.00 Cooling 74.00

45 50 55 60 65 70 75 80 85 90 95 100

space temp 71.2 °F

lock at value: 0.0 °F

high alarm unocc high limit: 95.0 °F

low alarm unocc low limit: 45.0 °F

sensor failure

Click to edit alarm limits

Click to edit setpoints

Adjust setpoints

- **Programmed setpoints** are set and changed by operators.
- **Effective setpoints** reflect the impact of other system conditions on the programmed setpoints, such as setpoint adjustments, and hysteresis. Effective setpoints control the equipment.

To change programmed setpoints:

- 1 Navigate to a setpoint control in one of the following places:
 - **Properties** page > **Control Program** tab > **Configuration** > **Setpoints**
 - The setpoint microblock pop-up on a **Logic** page
 - A **Graphics** page (Click a setpoint trend graph control to access the editable setpoint bar.)
- 2 Make changes on a programmed setpoint bar by either:
 - Clicking and dragging the segment or the gap between segments
 - Typing new values in the **Heating** and **Cooling** fields
- 3 Click **Accept**.

Demand Control

Demand Control is a cost-saving strategy that saves energy while maintaining comfort in the following ways:

- Controlling energy use to avoid peak demand, ratchet, or time of use utility charges
- Maintaining ventilation at relaxed setpoints rather than shutting down equipment (as with load shedding or duty cycling)

Before you can use Demand Control effectively, you must:

- Obtain details regarding past energy usage and peak demand, ratchet, and time of use charges from your energy provider.
- Understand the demand profiles of the zones you are controlling.

Demand Control can be customized at the zone level. For example, you may relax the setpoints in some zones, like break rooms and closets, by a few degrees, but you may not want to relax setpoints in computer rooms at all.

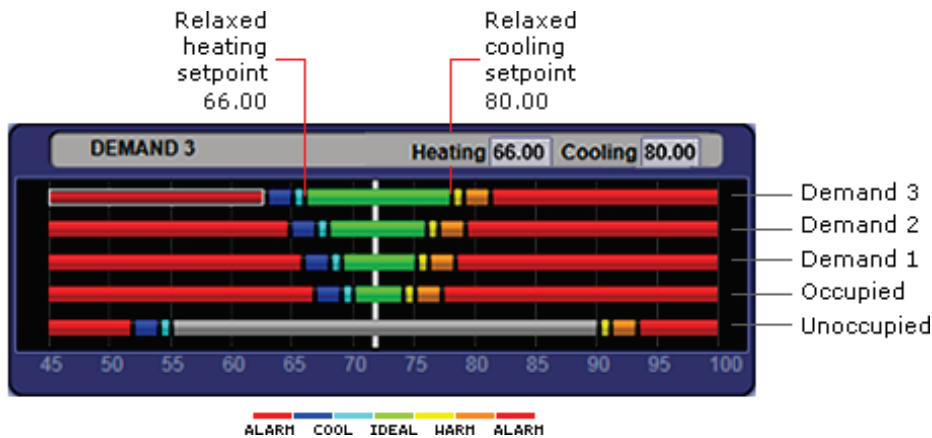

To define Demand Control properties

- 1 On the navigation tree, select the electric meter.
- 2 Select **Properties** > **Control Program** and expand the **Demand Level Parameters** section.
- 3 Type the **Start** and **End** time to define the time period that you want demand control to be in effect for this zone.
- 4 Type kilowatts per hour (kW/hr) in the **Level** columns to define the amount of power that the demand must exceed before the i-Vu® system calls for a higher demand level.

NOTE Levels are defined in the electric meter control program in the Snap application. You can test the Demand Levels by locking the meter to a value.

In the example below, during Period 4, defined as 12:00 (noon) to 16:00 (4:00 p.m.), if the demand exceeds 800 kW/hr, the i-Vu® system will use Demand Level 1 setpoints. If the demand exceeds 1000 kW/hr, the i-Vu® system will use Demand Level 2 level setpoints and so on.

▼ Demand Level Parameters

Current Demand Level: 0

Period	Start (hh:mm)	End (hh:mm)	Level 1 (kW)	Level 2 (kW)	Level 3 (kW)
1	0:00	4:00	980	1500	1800
2	4:00	8:00	950	1400	1650
3	8:00	12:00	875	1200	1375
4	12:00	16:00	800	1000	1200
5	16:00	20:00	900	1300	1450
6	20:00	24:00	1000	1550	1800

Configuring Optimal Start

Enable and configure Optimal Start on the **Properties** page > **Control Program** tab > **Configuration** > **Setpoints**. Your control program could be configured for **Optimal Start** or for both **Optimal Start** and **Optimal Start Type**.

NOTES

- The **Optimal Start** options depend on the revision date of the control program in your controller.
- Optimal Start is automatically disabled when **Properties** > **Control Program** > **Maintenance** > **Occupancy** > **BAS On/Off** is set to either **Unoccupied** or **Occupied**.

Optimal Start

Optimal Start adjusts the effective setpoints to achieve the occupied setpoints by the time scheduled occupancy begins. The Optimal Start recovery period may begin as early as 4 hours prior to occupancy. The algorithm works by moving the unoccupied setpoints toward the occupied setpoints. The rate at which the setpoints move is based on the outside air temperature, design temperatures, and capacities.

The following conditions must be true for optimal start to operate:

- On the **Properties** page > **Control Program** tab > **Configuration** > **Setpoints** > **Optimal Start**, the **Default Value** must be set greater than **0** and less than or equal to **4** (**0.00** disables **Optimal Start**).
- The system is unoccupied

NOTE If the Open controller does not have a valid outside air temperature, then a constant of 65° F is used. This value is not adjustable.

The actual equation that the controller uses to calculate **Optimal Start** is nonlinear. An approximation of the result is shown below.

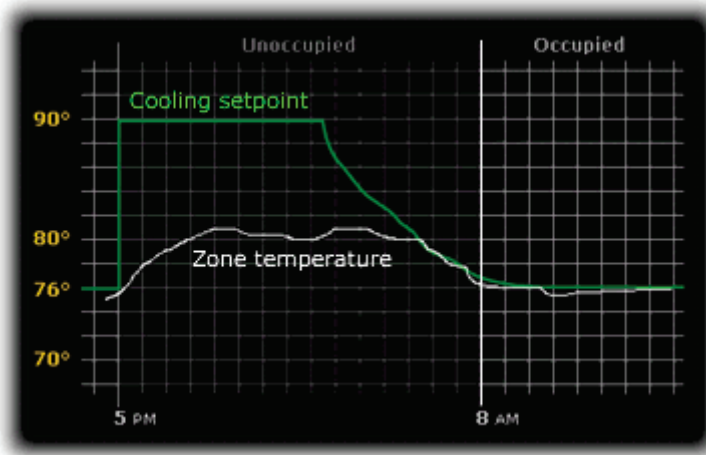

To change **Optimal Start** settings:

- 1 In the navigation tree, select the equipment that you want to change.
- 2 Select **Properties** page > **Control Program** tab > **Configuration** > **Setpoints**.

Optimal Start Type

If you have **Optimal Start Type**, you must choose from the following:

- **None**
- **Temperature Compensated Optimal Start**
- **Learned Adaptive Optimal Start**

To select the method used to change from unoccupied to occupied setpoints:

- 1 In the navigation tree, select the equipment that you want to change.
- 2 Click **Properties** page > **Control Program** tab > **Configuration** > **Setpoints**.
- 3 Select option from the **Optimal Start Type** drop-down list.
- 4 See below to make further adjustments.

None – The unit will not start to control to the occupied setpoints until the unit goes into an occupied mode. Setpoints do not ramp, but change immediately from unoccupied to occupied values. When you select **None**, you must set all Learning Adaptive Optimal Start transition factors, identified by their thermographic color, to 0. These are located directly above the **Effective Set Points** graph.

Temperature Compensated – The unit changes to occupied setpoints at some time prior to the occupied time, not to exceed the hours you set for **Optimal Start**. The start time is determined by the current error between space temperature and the appropriate heating or cooling setpoint. At that time, the setpoints do not ramp, but change immediately from unoccupied to occupied values. When selecting **Temperature Compensated**, you must set all Learning Adaptive Optimal Start transition factors, identified by their thermographic color to 0. These are located directly above the **Effective Set Points** graph.

When selecting **Temp Compensated**, you can adjust the following:

- **Heat Start K factor (min/deg)** – If **Optimal Start Type** is **Temp Compensated**, this is the time in minutes per degree that the equipment starts before the occupied period when the space temperature is below the occupied heating setpoint (including any setpoint offset).
- **Cool Start K factor (min/deg)** – If **Optimal Start Type** is **Temp Compensated**, this is the time in minutes per degree that the equipment starts before the occupied period when the space temperature is above the occupied cooling setpoint (including any setpoint offset).

NOTE The default value for the above is 15.00 and the range is 0 to 99.

Learning Adaptive Optimal Start – This function gradually adjusts the unoccupied setpoints over a specified period of time to achieve the occupied setpoint by the time scheduled occupancy begins. This learning adaptive algorithm uses the **learned heating capacity** and **learned cooling capacity** values to calculate the effective setpoints prior to the occupied start time. The algorithm calculates a learned cooling and heating capacity during the previous unoccupied time. Set the **Learning Adaptive Optimal Start** recovery period from 1 to 4 hours in **Optimal Start**. When the **Learning Adaptive Optimal Start** routine runs, adjustments are based on the color that is achieved when occupancy begins. Adjustment amounts are defined in the thermographic color fields located directly above the **Effective Setpoints** graph under **Setpoints**.

EXAMPLE The heating capacity for a zone is 5° per hour (default). When the zone becomes occupied, the zone temperature is 1° below the occupied setpoint, indicating a need for additional heat. Because the zone temperature was low by 1°, the learned heating capacity is decreased by the value entered in the **LtBlue** thermographic color field (0.0600 default). As a result, the learned heating capacity is adjusted to 4.94° for the next optimal start period. Since the algorithm has calculated that the equipment has less capacity to bring the temperature to setpoint within the configured recovery period, the setpoint adjustment begins sooner in the next unoccupied period.

To change the adjustment values in the **Learning Adaptive Optimal Start** routine:

- 1 In the navigation tree, select the equipment that you want to change.
- 2 Click **Properties** page > **Control Program** tab > **Configuration** > **Setpoints**.
- 3 Adjust the color fields between the Zone Setpoints graph and the the **Effective Setpoints** graph.

When you determine that no further start time optimization is required, you can disable **Heating** and **Cooling Capacity** adjustments by setting the color field values to 0.0.

You can reset the learned heating and cooling capacities by entering a value into either the **Heating Capacity** or **Cooling Capacity**, located beneath the **Zone Setpoints** graph.

The screenshot displays the 'Setpoints' configuration page. At the top, there are tabs for 'Control Program', 'I/O Points', 'Alarm Sources', 'Trend Sources', 'Network Points', and 'BACnet Points'. The 'Configuration' section is expanded to show 'Unit Configuration' and 'Setpoints'. Under 'Setpoints', there are two graphs: 'Zone Setpoints' and 'Effective Setpoints'. Below the 'Zone Setpoints' graph, there are input fields for 'Heating Capacity: 3.00', 'Cooling Capacity: 3.00', 'Heating Design Temp: 0.0', 'Cooling Design Temp: 100.0', 'Hysteresis: 0.3', and 'Min Setpoint Separation: 4.0'. Below these is the 'Learning Adaptive Optimal Start' section, which includes a row of color-coded adjustment factors: Red (0.1900), DkBlue (0.1300), LtBlue (0.0600), Green or SpGrn (0.0600), Yellow (0.0600), Orange (0.1300), and Red (0.1900). Below this is the 'Effective Setpoints' graph. At the bottom, there are fields for 'The learned cooling capacity is 3.00 ;' and 'The learned heating capacity is 3.24 ;'. Finally, there is a table of 'Optimal Start' parameters: 'Optimal Start' (BAV) 1 hr (Default Value: 1.00), 'Optimal Start Type' (BMSV) Temp Compensated (Default Value: Temp Compensated), 'Heat Start K factor (min/deg)' (BAV) 15 (Default Value: 15.00), and 'Cool Start K factor (min/deg)' (BAV) 15 (Default Value: 15.00).

Allows learned cooling and heating capacities to reset.

Thermographic color fields determine the adjustment factors for Learning Adaptive Optimal Start.

Sets the maximum allowable recovery period.

Selects the type of Optimal Start algorithm.

CAUTION When using **Learning Adaptive Optimal Start**, be sure that all equipment is properly maintained so that your system does not “learn” to compensate for dirty filters or loose fan belts.

Schedules

Using schedules, your equipment can maintain one set of setpoints during occupied periods to provide comfort, and it can maintain a different set of setpoints during unoccupied periods to reduce energy consumption. Schedules are an i-Vu® system's most effective cost-saving strategy.

In the **User** view, you can apply a schedule to a single tree item or to a group of tree items.

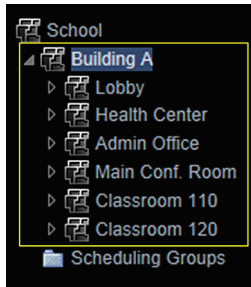

When you apply a schedule to a tree item, the schedule affects equipment at and below the area or equipment where the schedule was added.



When you apply a schedule to a schedule group, the schedule affects all pieces of equipment in the group.

For example, a school board meets every third Tuesday of the month and uses the lobby, main conference room, break room, and restrooms. You can create a schedule group to control these different areas with a single schedule.

NOTES

- When multiple schedules affect a tree item, the net result is the *Effective schedule* (page 63).
- Do not include preheating or precooling time in your schedules. *Optimal Start* (page 56), another cost-saving strategy, automatically calculates and controls precise preheating and precooling routines.
- If your system has no need to run schedules, you can turn off this feature. First, delete any existing schedules. Then go to the System Options (or System Settings) > *General tab* (page 25), and check the box **Disable Schedules feature**.

To view schedules

- 1 Select a navigation tree item (site, area, or equipment).
- 2 Click **Schedules > View** tab.
- 3 Optional: Click a white **Effective** bar to view all the schedules that contribute to the resulting schedule. If the item has multiple schedules, the schedule closest to the **Effective** bar has the highest priority. You set a schedule's priority when you create the schedule.

NOTES

- When multiple schedules affect a single area or controller, the i-Vu® application sorts the schedules by priority - the higher the priority, the closer the schedule is to the bar. You set a schedule's priority when you add a schedule.
- You can also view schedules on the following detailed, printable schedule reports. These reports are accessible from the **Schedules** page > **Reports** tab or from the **Reports** button drop-down menu.

This report...	allows you to...
Schedule Instances	Find every schedule with its location that is entered at and below a selected tree item. This report can help you discover newly added and conflicting schedules.
Effective Schedules	View all equipment that may be scheduled and the net result of all schedules in effect for a selected date and time. See <i>Effective schedules</i> (page 63).

To print schedules

- 1 Select a navigation tree item and click **Reports** .
- 2 Click **Schedules** > **Schedule Instances** or **Effective Schedules**.
- 3 Click **Run**, then click **PDF**.

This report...	allows you to...
Schedule Instances	Find every schedule with its location that is entered at and below a selected tree item. This report can help you discover newly added and conflicting schedules.
Effective Schedules	View all equipment that may be scheduled and the net result of all schedules in effect for a selected date and time.

To apply a schedule to equipment

Schedules in the i-Vu® application are typically based on zone occupancy.

- 1 In the User navigation tree, select the area or equipment you want to schedule .

NOTES

- To schedule all equipment in a specified area, select the area you want.
 - You can schedule individual controllers from the **Installer** view, but you must be in the **User** view to schedule areas and routers
- 2 Click **Schedules**, then **Configure** tab.
 - 3 Click **Add**.

- 4 Select a **Priority**. A schedule's priority determines whether affected zones will use occupied or unoccupied setpoints.

Select...	For...
Normal	A typical occupied period
Holiday	An unoccupied period that overrides a Normal schedule
Override	An occupied period that overrides a Holiday schedule

- 5 Select a **Type**. See table below.
- 6 Type a schedule name in the **Description** field (50 characters maximum).
- 7 Enter desired values in the fields below **Description**.
- 8 On the graph, change a time segment's **Start** and **End** times by doing one of the following:
- Click the segment, then type the times in the **Start** and **End** fields.
 - Click and drag either end of the segment or the entire segment.
- 9 Optional: Click **Add Time Period** to add one or more segments to the schedule. Or, select a segment and click **Delete Time Period** to delete that segment.
- 10 Click **Accept**.

Select this Type...	To use the schedule...
Weekly	Every week on the specified days
Date	On a single, specified date
Date Range	Between 2 specified dates
Date List	On multiple, specified dates
Wildcard	According to a repeating pattern (For example, the second Tuesday of every month)
Continuous	Continuously between specified times on 2 separate dates
Dated Weekly	Weekly between a start date and an end date (For example, the summer break in the school year)

NOTES

- To automatically download all schedules that you create or change, click  > **System Options** > **My Settings** and, under **Preferences**, select **Automatically download schedules on each change**. If you want to manually download schedules, clear the **Automatically download...** field and then see *Downloading system changes to controllers* (page 148).
- When you apply a schedule to an item on the navigation tree, the schedule affects that item and all children of that item. If you do not want an item to be affected by schedules from a higher level, select **Ignore Schedules above this level** on the **Schedules** > **Configure** tab.

To apply a schedule to a group of items

You must create a group, then add members (areas, equipment, or other groups) to the group before you can apply a schedule to it.

- 1 On the **User** navigation tree, select **Scheduling Groups**.
Optional: If you have created folders to organize your groups, select the appropriate folder. See "To organize groups using folders" below.
- 2 Click **Add Group**.
- 3 Type a name for the new schedule group in the **Name** field.
- 4 Optional: Change the default **Reference name**. A group's reference name must be unique throughout the system.
- 5 Click **Accept**.
- 6 Click **Add Members to Group**.
- 7 On the **Members** page, select the areas, equipment, or other groups that you want to add to the group from the tree on the right. Use **Ctrl+click**, **Shift+click**, or both to select multiple items.
- 8 Click **Add**.
 **TIP** Use the **Raise** and **Lower** buttons to reorder items in the **Members** list. Changing the order is for your viewing convenience and does not affect the system.
- 9 Click **Accept**.
- 10 You will see the question **Execute download now?**. Click **OK**.
- 11 Click the **Schedules** button, then **Configure**.
- 12 Add a schedule to the group. See *To apply a schedule to equipment* (page 60).

To organize groups using folders

You can create folders and sort your groups into them to organize the Schedule Groups tree. For example, a large school system that has a group for each school may want to create an Elementary School folder, a Middle School folder, and a High School folder, and put the appropriate groups in each folder.

To create folders and add groups to them:

- 1 On the **User** tree, select **Scheduling Groups**.
- 2 Click **Add Folder**.
- 3 Type a name for the new folder in the **Name** field.
- 4 Optional: Change the default **Reference name**.
- 5 Click **Accept**.
- 6 Repeat steps 1–4 for each folder that you want to add.
- 7 Do one of the following to add a group to a folder:
 - If you have already created the group, drag and drop it into the appropriate folder in the tree on the **Scheduling Groups** page, then click **Accept**.
 - Select the folder in the tree on the **Scheduling Groups** page, then click **Add Group** to add a new group inside the folder.

NOTE You can also add a folder to a folder, or drag and drop a folder into another folder.

To edit or delete a schedule

- 1 Do one of the following:
 - On the navigation tree, select the tree item where the schedule was defined, then select **Schedules > Configure** tab.
 - In the **User** tree, click **Scheduling Groups**, then select the group that has the schedule you want to edit or delete.
- 2 Select the schedule you want to edit or delete.
- 3 Edit the fields you want to change or click **Delete**.
- 4 Click **Accept**.

NOTE Expired dated schedules are automatically deleted from the database at 3:30 AM every day. But expired schedules remain in the controller until the next time schedules are downloaded to the controller.

Effective schedules

The effective schedule that you see on the **Schedules > View** tab can be the result of multiple overlapping schedules.

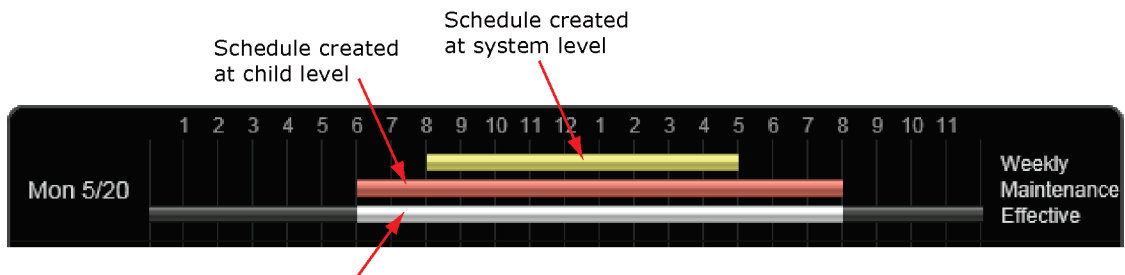

Effective schedule — Click the white bar to see the schedules that result in the effective schedule.

The following schedule features can influence an item's effective schedule.

Feature	Description
Hierarchy	<p>A schedule applied to an item on the i-Vu® tree affects that item and all of its children. A child item's combined schedule could be the result of multiple schedules applied at different levels above it. To change a child item's combined schedule:</p> <ul style="list-style-type: none"> • Add a schedule at the child that overrides the current schedule. See the <i>Priority</i> feature below. • Set the child to ignore the parent schedules. To do this, select the child item on the tree, then go to Schedules > Configure. Select the schedule, then click Ignore Schedules above this level. You can then add a different schedule for the child. <p>Any schedule change that you make to an item affects it and all of its children.</p>

Feature	Description								
Priority	You must assign one of the following priorities to every schedule.								
	<table border="1"> <thead> <tr> <th>Use...</th> <th>For...</th> </tr> </thead> <tbody> <tr> <td>Normal</td> <td>A typical occupied period</td> </tr> <tr> <td>Holiday</td> <td>An unoccupied period that overrides a Normal schedule</td> </tr> <tr> <td>Override</td> <td>An occupied period that overrides a Holiday time</td> </tr> </tbody> </table>	Use...	For...	Normal	A typical occupied period	Holiday	An unoccupied period that overrides a Normal schedule	Override	An occupied period that overrides a Holiday time
Use...	For...								
Normal	A typical occupied period								
Holiday	An unoccupied period that overrides a Normal schedule								
Override	An occupied period that overrides a Holiday time								
	<p>EXAMPLE For a school, you define:</p> <ul style="list-style-type: none"> • A Normal schedule that has it occupied every Monday–Friday, 6 am–5 pm • A Holiday (unoccupied) schedule for the week of Spring Break • An Override schedule on the first day of Spring Break from 9 am–1 pm for the cafeteria only where a teacher's meeting will be held. 								
Type	You must assign one of the following types to every schedule.*								
	<table border="0"> <tr> <td>Weekly</td> <td>Wildcard</td> </tr> <tr> <td>Date</td> <td>Continuous</td> </tr> <tr> <td>Date Range</td> <td>Dated Weekly</td> </tr> <tr> <td>Date List</td> <td></td> </tr> </table> <p>See <i>To apply a schedule to equipment</i> (page 60) for a description of each type.</p> <p>EXAMPLE For a school, you define the following 3 schedules:</p> <ul style="list-style-type: none"> • Full calendar year: Normal, Weekly, Monday–Friday, 6am–5pm • Summer months: Holiday, Continuous, 12am June 1st –11:59pm August 31st • Work days in summer months: Override, Dated Weekly, Monday–Thursday, 9am–2pm 	Weekly	Wildcard	Date	Continuous	Date Range	Dated Weekly	Date List	
Weekly	Wildcard								
Date	Continuous								
Date Range	Dated Weekly								
Date List									

Using the **Priority** and **Type** options, you can often accomplish the combined schedule you need in several different ways. For example, the combined schedule resulting from the 3 schedules described above for **Type** could also be accomplished with the following schedules:

School year: Normal, Dated Weekly, Monday–Friday, September 1st–May 31st, 6am–5pm

Summer months: Normal, Dated Weekly, Monday–Thursday, June 1st–August 31st, 9am–2pm

i-Vu® CCN schedules

There are 2 types of CCN schedules:

- 1 – 64 are local schedules that reside within the equipment
- 65 – 99 are network or global schedules, which are sent over a CCN network and received by controllers that contain network schedules

The i-Vu® application supports both local and global schedules.

Most CCN equipment is shipped with the default schedule of **64**. See exceptions below.

Equipment	i-Vu®'s default schedule number
Comfort Controller/UC/Expansion Controllers	0
Any controllers using a custom equipment file (*.equip) created with EquipmentBuilder	0
Gen III VVT, 48/50EJ (Conquest), FSM, CSM	1
All PICs	64



CAUTION! Confirm the actual schedule numbers that are used in the controller, as they may have been changed from their programmed default settings.

In order to use i-Vu® schedules, the i-Vu® schedule number must match the CCN schedule number at the controller. This can be set in the i-Vu® interface by selecting the equipment in the navigation tree and clicking **Schedules > CCN** tab. It is also accessible at the area or site level.

NOTE To reduce start-up labor on a retrofit project, existing network schedules can be used by the i-Vu® application. However, switching to local schedules allows for schedule retention after a power failure and local schedule maintenance tables.

If a controller uses a different schedule number, complete the following steps.

CAUTION! Failure to follow these steps may result in unexpected equipment operation.

- 1 On the navigation tree, select the controller.
- 2 Click the **Schedules** page, then **CCN** tab.
- 3 Adjust the following fields:
 - **Schedule number** - enter the CCN schedule number in use at the controller.
 - **Override time (optional)** - enter the number of minutes of the desired override and verify that the controller override time is greater than or equal to this number
 - **Override group** - enter the number of the group, if you have established one

Alarms

A message is sent from an alarm source to i-Vu® to notify you that certain conditions exist, such as a piece of equipment that has stopped running or a temperature that is too high. When i-Vu® receives an alarm, it displays information about the alarm on the **Alarms** page. i-Vu® can also perform *alarm actions* (page 72) to inform personnel of the condition. An alarm source can also send a return-to-normal message when the alarm condition returns to its normal state.

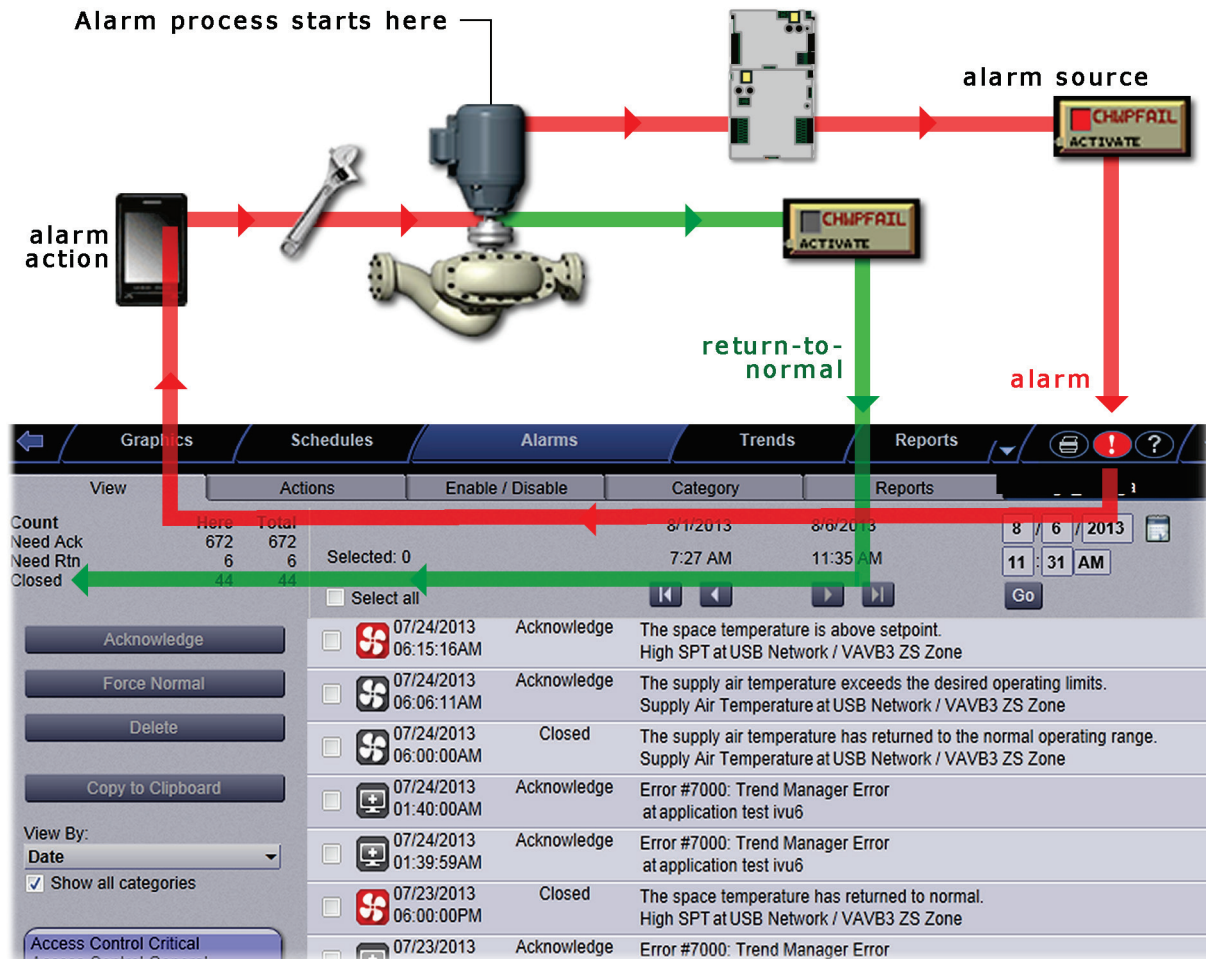

Alarm sources and the alarms they generate are assigned to categories, such as HVAC Critical or HVAC Maintenance, to help you work with related alarms.

The application engineer usually sets up alarm sources in the Snap application. In the i-Vu® interface, you can:

- *View, troubleshoot, acknowledge, and delete alarms* (page 67)
- *Set up the alarm actions that the i-Vu® application performs* (page 72)
- *Edit alarm sources that were set up in the Snap application or set up new alarm sources to generate alarms* (page 79)

NOTE In addition to the alarms that you set up, i-Vu® has built-in system and equipment alarms.

Viewing, acknowledging, and deleting alarms

The i-Vu® **Alarms** page displays alarms as they are received. If desired, an operator can set options on  > **System Options** > **My Settings** tab to have the i-Vu® application play an audio file when an alarm is received.



An alarm's setup may require that it be acknowledged and/or the alarm condition returned to normal. The alarm, its return to normal, and any other alarms related to the incident are referred to as an alarm incident group. The i-Vu® application closes an alarm incident group when all of the following have occurred:

- You acknowledge the alarm (if required)
- The i-Vu® application receives a return-to-normal (if required)
- The i-Vu® application performs all alarm actions defined for the group

You should delete alarms from your system as they are closed because large quantities of stored alarms can reduce the efficiency of your system.

NOTE The **Installer** view does not display all alarms on the system or site level, only on the router and controller level. Go to the **User** view or click the system-wide alarms button to see all of the alarms in the system.

The color of the system-wide alarms button signifies one of the following conditions:

-  Red - Critical alarms need to be acknowledged.
-  Yellow - Non-critical alarms need to be acknowledged.
-  Grey - No alarms need to be acknowledged.

You must acknowledge alarms that have been set up to require acknowledgement. Right-click alarm message to print. To save alarm information before deleting, select **Alarms** > **Reports** tab > **Alarms** > click **Run** button.

To view alarms in the i-Vu® interface

- Click  at the top of the page to see all alarms in the system.
or
- Click the **Alarms** button and then select an item on the navigation tree to see all alarms at and below that level.

Alarms > View shows 50 alarms at a time. Click arrows to see more.

Click to see all alarms in system. Color indicates alarms need to be acknowledged.
 Red—Critical
 Yellow—Non-critical
 Gray—None

Click to expand or collapse

Show alarms by:
Date—most recent at top
To Do—Only alarms that require action
Incident Group—All alarms for one incident

Select the categories you want to see. Click, Shift+click, Ctrl+click, or select **Show all categories** checkbox.

Click to acknowledge or delete all alarms in selected categories, or to delete closed incident groups

Icon indicates alarm category

Click alarm to show or hide details.

Alarm status:
Acknowledge—Needs to be acknowledged. Red text indicates a return-to-normal is also required.
Waiting for normal—Requires return-to-normal
Closed—All required actions have been performed

Type or select a date. Click **Go** to see alarms since that date/time.

Selected: 1

Count	Here	Total
Need Ack	10	10
Need Rtn	7	7
Closed	3	3

View	Actions	Enable / Disable	Category	Reports
1/28/2013	9:38 AM	10:13 AM		

1 / 28 / 2013
10 : 45 AM
Go

01/28/2013 Acknowledge The space temperature is too warm. TEMP_HI at Router 41 / Aaron's Cp1

01/28/2013 Acknowledge The space temperature is too cool. TEMP_LO at Router 41 / Aaron's Cp2

01/28/2013 Acknowledge The space temperature is too warm. TEMP_HI at Router 41 / Aaron's Cp2

01/28/2013 Closed The space temperature has returned to normal. TEMP_HI at Router 41 / Aaron's Cp2

01/28/2013 Closed The space temperature has returned to normal. TEMP_LO at Router 41 / Aaron's Cp1

01/28/2013 Acknowledge The space temperature is too cool. TEMP_LO at Router 41 / Aaron's Cp1

Category: HVAC Critical
Previous State: NORMAL
Returned to Normal: 01/28/2013 09:44:50AM

01/28/2013 Closed The space temperature has returned to normal. TEMP_LO at Router 41 / Aaron's Cp1

NOTES

- Alarms generated by the i-Vu® application appear at the system level.
- Alarms generated by controllers appear at the system level in the **User** view.
- An alarm's details include a path to the alarm source. Each section of the path is a link to that location. For example, in the path **West TEMP LO at Router 41/Sunshine Corp**, TEMP LO links to the microblock's Properties page, and Sunshine Corp links to the Sunshine Corp West Wing graphic, TEMP-LO links to the equipment graphic.

- You may see any of the following alarms icons in i-Vu®.

<u>These icons...</u>	<u>Indicate...</u>	<u>Icon color indicates...</u>
	Access control	Red = Critical
	HVAC	Blue = Maintenance
	Fire system	Gray = General
	Lighting system	Grayed out = Closed
	General alarm	
	Unknown	
	System	
	FDD	
	FDD comfort	
	FDD energy	
	General message	
	Controller alarm	

To control which alarms you see

<u>Use these tools...</u>	<u>To control the Alarms list</u>
<p>Oldest alarms Newest alarms</p> <p>Previous 50 alarms Next 50 alarms</p>	<p>Click the arrow buttons to display other alarms.</p>
	<p>Type a date and time or click to select a date. Then click Go to show up to 50 alarms since that date/time.</p> <p>When finished, click to display the 50 newest alarms or to display the oldest 50 alarms.</p>

Use these tools...



To control the Alarms list

Date—Sorts list by date/time the alarms were generated with the most recent at the top.

To Do—Shows only alarms that require one or more actions before they are closed.

Incident Group—Sorts alarms by incident. For example, an alarm and its return-to-normal form an incident group. Brackets indicate a group.

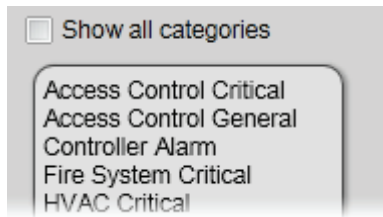
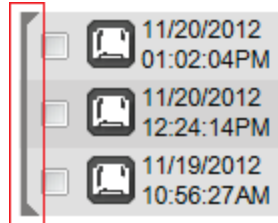

Select the alarm categories that you want to see in the alarms list. Use **Ctrl+click**, **Shift+click**, or both to select multiple categories, or check **Show all categories**.

To acknowledge alarms

You must acknowledge alarms that have been set up to require acknowledgment. An alarm shows if it needs to be acknowledged.

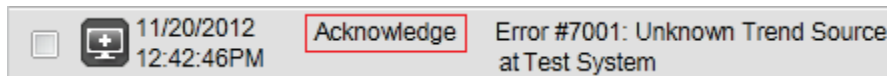

The table in the upper left corner of the page shows how many alarms need acknowledgment at the current location (**Here**) and in the entire system (**Total**). This table also shows how many alarms need a return-to-normal and how many are closed.

View	Message	
Count	Here	Total
Need Ack	637	637
Need Rtn	12	12
Closed	0	0

To acknowledge an alarm

- 1 On the **Alarms** page > **View** tab, select the checkbox of an alarm that shows **Acknowledged**.
- 2 Click the **Acknowledge** button.

To acknowledge all alarms in the alarms database for selected categories

- 1 On the **Alarms** page > **View** tab in the left-hand column, select the categories whose alarms you want to acknowledge.

NOTE Use **Ctrl+click**, **Shift+click**, or both to select multiple categories, or select the **Select All** checkbox.

- 2 Click **Advanced**.
- 3 Click **Acknowledge All**.



TIP Acknowledging many alarms simultaneously can take a long time. Acknowledge alarms as they occur to avoid long waits.

To delete alarms

You should delete alarms from your system as they are closed because large quantities of stored alarms can reduce the efficiency of your system. To save alarm information before deleting, select **Alarms > Reports** tab > **Alarms**, then click the **Run** button.

To delete an alarm

- 1 On the **Alarms** page > **View** tab, select an alarm's checkbox.
- 2 Click **Delete** under **Manage List**.

To delete all alarms in the alarms database for selected categories

- 1 On the **Alarms** page > **View** tab, click **Filter View** at the bottom of the page.
- 2 Select the categories whose alarms you want to delete.

NOTE Use **Ctrl+click**, **Shift+click**, or both to select multiple categories, or select the **Select All** checkbox.

- 3 Click **Advanced**.
- 4 Click **Delete All**.

To delete all closed alarm incident groups in the alarms database

An incident group is all alarms related to a particular incident. For example, an alarm and its return-to-normal form an alarm incident group. An incident group is considered closed when all alarms in the group are closed.

- 1 On the **Alarms** page > **View** tab, click **Filter View** at the bottom of the page.
- 2 Select the categories whose alarms you want to delete.

NOTE Use **Ctrl+click**, **Shift+click**, or both to select multiple categories, or select the **Select All** checkbox.

- 3 Click **Advanced**.
- 4 Click **Delete Closed Incidents**.

NOTE An alarm source may be set up to generate an alarm and a return-to-normal. If an alarm occurs but the i-Vu® application never receives the return-to-normal, you can select the alarm and then click **Force Normal** so that the alarm can be closed. **Force Normal** has no effect on the alarm condition that generated the alarm.

To receive audible notification of alarms

You can set up the i-Vu® application to play an audible alert on your workstation when it receives a critical or non-critical alarm.

- 1 Click , then select **System Options > My Settings**.
- 2 Under **Preferences**, select **Non-critical alarms** or **Critical alarms** to be notified of them.

When an alarm triggers the audible alert, you can click  and then select:

- **Snooze** to temporarily stop the sound for 5 minutes
- **Silence** to stop the sound

The alarm sound is silenced until another alarm that triggers a sound is received.

Setting up alarm actions

Alarm Action - An action that the i-Vu® application performs to notify personnel of an alarm or to record information about the alarm. You can assign alarm actions to an alarm source, a category of alarm sources, alarm sources from a certain location, or a combination of these criteria.

To assign alarm actions to alarm sources:

Although you can assign an alarm action to an individual alarm source, you typically assign an action to multiple alarm sources at the area or equipment level. The alarm action applies to all instances of the alarm sources at the selected location and below. Click an action's **Edit** button to make any changes.

To assign an alarm action to alarm sources:

- 1 On the navigation tree, select the area or equipment, containing the alarm sources.
- 2 Click **Alarms > Actions** tab and follow the 3 steps on the screen.
NOTE Use Ctrl+click, Shift+click, or both to select multiple items.
- 3 Click **Add**.
- 4 Set up the alarm action by editing the fields on the alarm action page. See the appropriate alarm action below for field descriptions.
- 5 Click **OK**.

Alarm Popup

The **Alarm Popup** alarm action pops up a message on any computer with a Windows operating system that is running the i-Vu® Alarm Notification Client application.

Field	Notes
To Operator To Group	Select individual operators or operator groups who should receive alarm notification.
Generate alarm if delivery fails	Select this checkbox to generate a System Info alarm if the popup recipient is not currently running the Alarm Notification Client application.
Message text	Use punctuation, spaces, or returns to format the text. To add live data to the text, select <i>field codes</i> (page 83) from the Append Field Code list.
Append Field Code	Add <i>field codes</i> (page 83) to the message text if desired.
Perform Action	By default, the i-Vu® application performs an alarm action when the alarm source generates an alarm and when it returns to normal. Under Perform Action , you can choose to run the alarm action only when the alarm source generates an alarm or when it returns to normal.

Using the Alarm Notification Client application





The Alarm Notification Client application must be running on each client computer (Windows only) that should receive popup notifications. Keep the application minimized to the right side of the Windows task bar. The window will pop up with a message when an alarm occurs.

NOTE To use the i-Vu® Alarm Notification Client application across a firewall, you must open UDP port 47806.

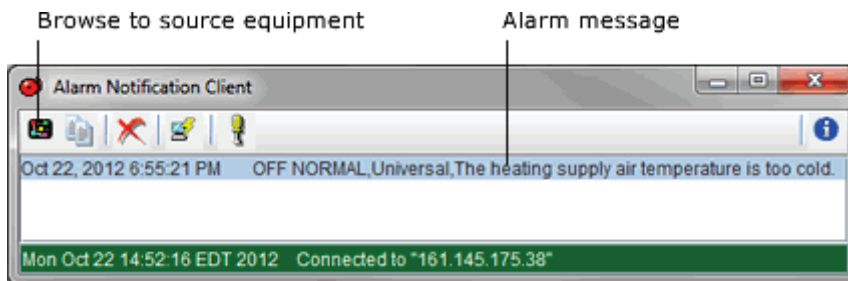
Select an alarm message, then click  to open i-Vu® displaying the piece of equipment that generated the alarm. A grayed out alarm indicates that it was acknowledged in the i-Vu® interface.

If the Alarm Notification Client is set up to play a continuous alarm sound, you can silence an alarm by clicking **Silence!**, by pressing **Ctrl+S**, or by acknowledging the alarm in the i-Vu® interface.



Button	Notes
	Opens the i-Vu® interface displaying the equipment that generated the alarm.
	Copies the selected alarm information to the clipboard.
	Removes the alarm information from the alarm popup list. Removing items from this list has no effect on the alarms list in the i-Vu® interface.
	View information about the server connection.
	On this tab... You define...
Server Connection	The i-Vu® web server and port, and the i-Vu® operator name and password
Browse To	The i-Vu® page that you want to see first when browsing to the equipment
Notification Sounds	<ul style="list-style-type: none"> If you want to hear a sound when an alarm occurs Which sound you want to hear for each type of alarm. NOTE A Connection Failure occurs when the Alarm Notification Client loses communication with the i-Vu® application. Whether you want the sound to continue until silenced <p>NOTE If multiple types of alarms occur simultaneously, the application plays the sound of the most critical alarm (Connection Failure first, then Critical, then Normal).</p>

To set up the i-Vu® application to support Alarm Popup clients

- 1 Click , then select **System Options > General** tab, and then select **Enable support for Alarm Notification Clients to connect to this server**.
- 2 Leave **Restrict to IP Address** field blank.
- 3 Use the default port.
- 4 Click **Accept**.

NOTE If the Alarm Notification Client application is not on the local network and will access i-Vu® alarms through a NAT router, your Network Administrator must port forward the TCP port you defined in step 3 above.

To install the Alarm Notification Client application

Follow the steps below on each client computer that should receive alarm popups.

PREREQUISITE You must enable Alarm Popup support in **System Options > General** tab. See above topic. Click , then select **System Options > General** tab, and then check **Enable support for Alarm Notification Clients to connect to this server**.

- 1 Install software from your **Tech Tools** USB drive or DVD.
- 2 Click **Alarm Popup Application**.

- 3 Click **Run**, then follow the on-screen instructions to install the Alarm Notification Client application. After you click **Done**, the application starts automatically.

NOTE To locate your applicable IP address, look in the **Management Tool**.

- 4 In the **Settings** dialog box, enter appropriate values. You can also click  to open this box. See the table above for a description of each setting.

NOTE You can lock the **Settings** so that a user cannot edit them. See *To lock a client's Settings feature* below.

- 5 Click **OK**.
- 6 Minimize the Alarm Notification Client window.

To lock a client's Settings feature

To prevent a user from editing the **Settings** :

- 1 Right-click **Alarm Notification Client** in the Windows **Start** menu.
- 2 Select **Properties**.
- 3 On the **Shortcut** tab, type `-lockconfig` at the end of the **Target** path.

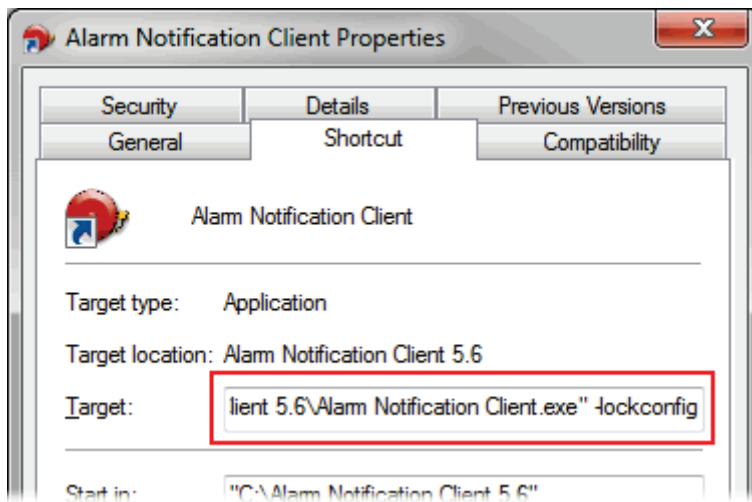

Send E-mail

The **Send E-mail** alarm action sends a message to one or more e-mail accounts. The alarm action can also run a report and attach it to the e-mail as a PDF, HTML, or XLS file.

Field	Notes
To and CC	Type the address(es) that you want to send the alarm to. To enter multiple addresses, type a space or press Enter after each address.
Subject	Enter the text that you want to appear on the Subject line of the email. The subject can include <i>field codes</i> (page 83).
Use default email server configuration	Check this field to have this alarm action use the email server configuration settings defined on the System Options > General tab. Uncheck to enter settings specific to this alarm action.
From	Enter a valid address if required by your mailserver.
Mail Host	The mailserver's address. This can be an IP address or a system name, such as mail.mycompany.com.
Mail Host Port	Change this field if using a port other than the default port 25.
Mail Host Security Options	Select the type of security the mailserver uses. <ul style="list-style-type: none"> • Cleartext (SMTP) – Uses the SMTP protocol to send as clear text over TCP/IP • Secure SSL (SMTP with SSL) – Uses SSL, a communication protocol that provides data encryption • Secure TLS (STARTTLS) – Uses TLS, but does not begin encryption until the i-Vu® application issues STARTTLS command
Specify Mail User For Mail Host Authentication	Select if your mailserver requires a username and password.
Send mail as MIME attachment	Select if your mailserver allows only MIME attachments.
Message Text	Use punctuation, spaces, or returns to format the text. To add live data to the text, select <i>field codes</i> (page 83) from the Append Field Code list.
Attach Report	Select to attach a report to the e-mail, then select the Report and the Format . The attached report will include the date and time. For example, Alarm Sources 2012 Jan 01 1230 . NOTE The Report Name field shows a custom report only if it is accessible at the current level. Run as shows the name and login name of the operator creating the alarm action. The report will be run using the privileges and report options of this operator.  TIP You may want to create a new operator with limited privileges for this purpose.

Field	Notes
Perform Action	<p>By default, the i-Vu® application performs an alarm action when the alarm source generates an alarm and when it returns to normal. Under Perform Action, you can choose to run the alarm action:</p> <ul style="list-style-type: none"> • Only when the alarm source generates an alarm or when it returns to normal. • After a specified amount of time if the alarm has not been acknowledged or has not returned to normal. Use this option for alarm escalation. • If the alarm occurs during the occupied hours defined for a schedule group or run if the alarm occurs during the unoccupied hours defined for a schedule group. EXAMPLE To have one alarm action performed during work hours and a different alarm action performed after work hours: <ol style="list-style-type: none"> 1. Create a <i>schedule group</i> (page 62), but do not assign members to it. 2. Create a schedule for the group. Set the occupied hours to be the same as the work hours. 3. Create the alarm action that is to be performed during work hours. Under Perform Action, select If schedule group <your new group> is Occupied. 4. Create the alarm action that is to be performed after work hours. Under Perform Action, select If schedule group <your new group> is Unoccupied.

NOTE You should not assign this alarm action to frequently-occurring alarms as this may cause problems on your network or the Internet.

Send Web Service Request

The **Web Service Request** alarm action sends a web service request to a third-party server when an alarm event occurs. For example, the i-Vu® application could send a request to a work order system so it could create a work order for someone to respond to the alarm condition.

Field	Notes
Destination Address	The URL of the server that will receive the request. Example: https://192.168.168.102/workorder/bas
Web Service Action	Select the type of web service request required by the target server: GET or POST
Content Type	If you selected POST in the previous field, select the format required by the target server: Application/json or /x-www-form-urlencoded
Web Service Request Parameters	Optional—Create a parameter for each piece of information that the target server requires. You should be able to find information about required parameters in the target server's documentation.
Parameter Name	Enter a name for the parameter. For example, Parm1 or Date. Click Add Parameter .
Value	Text required for the parameter. To add live data to the request, select a <i>field code</i> (page 83) from the Append Field list.
Perform Action	By default, the i-Vu® application performs an alarm action when the alarm source generates an alarm and when it returns to normal. Under Perform Action , you can choose to run the alarm action: <ul style="list-style-type: none"> • Only when the alarm source generates an alarm or when it returns to normal. • After a specified amount of time if the alarm has not been acknowledged or has not returned to normal. Use this option for alarm escalation. • If the alarm occurs during the occupied hours defined for a schedule group or run if the alarm occurs during the unoccupied hours defined for a schedule group. EXAMPLE To have one alarm action performed during work hours and a different alarm action performed after work hours: <ol style="list-style-type: none"> 1. Create a <i>schedule group</i> (page 62), but do not assign members to it. 2. Create a schedule for the group. Set the occupied hours to be the same as the work hours. 3. Create the alarm action that is to be performed during work hours. Under Perform Action, select If schedule group <your new group> is Occupied. 4. Create the alarm action that is to be performed after work hours. Under PerformAction, select If schedule group <your new group> is Unoccupied.

Setting up an alarm source in the i-Vu® interface

In the i-Vu® interface you can:

- Edit an alarm source's settings or set up a new alarm source to generate alarms.
- Select **Properties** page > **Alarm Sources** tab to set up all alarms associated with a particular piece of equipment
- Simulate an alarm to test its setup.

To set up, edit, or disable alarm sources

To set up, edit, or disable a single alarm source

- 1 On the navigation tree, select the control program.
- 2 Click **Alarms**, then select the **Enable/Disable** tab.
- 3 Make changes to the fields as needed. The fields can vary for different types of alarm sources. See table below.
- 4 Click **Accept**.



TIP To set up all the alarms for a piece of equipment at once, click **Properties**, then select **Alarm Sources**.



Field	Notes
Potential alarm source	Check to enable the alarm source to generate alarms. Uncheck to disable the alarm source.
Alarm enabled	<p>Check to have the alarm source generate an alarm when the specified conditions occur.</p> <ul style="list-style-type: none"> • For a binary input, enter the conditions for generating an alarm. • For an analog input, type the low and high limits that, when exceeded, will generate an alarm.

Deadband The amount inside the normal range by which an alarm condition must return before a return-to-normal notification is generated.

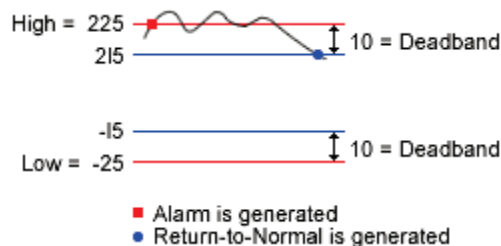
EXAMPLE



NOTE If the **Status** checkbox is selected, the alarm condition currently exists.

Field	Notes
Return to Normal	Check to have the alarm source generate a return-to-normal when the alarm condition returns to a normal state.
Alarm requires acknowledgement	Check to have the i-Vu® application require that an operator acknowledge the alarm.
Return requires acknowledgement	Check to have the i-Vu® application require that an operator acknowledge the return-to-normal.
Classified as critical	This property determines the color of the system-wide alarm button when the alarm comes in.  = Critical  = Non-critical
Event State	The current state of the alarm source can be: <ul style="list-style-type: none"> • Normal—value is normal • Off normal—the value is not normal (binary only) • Fault—the alarm source microblock may be misconfigured • High Limit—the value exceeds the normal range (analog only) • Low Limit—the value is below the normal range (analog only)
BACnet Configuration:	N/A
Dial on alarm	
Notification Class	Do not change this field.

To set up, edit, or disable multiple alarm sources simultaneously

- 1 On the navigation tree, select the area, equipment, or controller containing the alarm sources.
 - 2 Click **Alarms**, then select the **Enable/Disable** tab.
 - 3 In step **1**, select the categories that contain the alarm sources.
NOTE In step **1** and step **2**, **Ctrl+click**, **Shift+click**, or both to select multiple items, or select the **Select All** checkbox.
 - 4 In step **2**, select the alarm sources.
 - 5 Make appropriate changes in step **3**.
 - 6 Click **Accept**.
- NOTE** Click **View Selected Sources** to view or change settings for each alarm.

To view all instances of an alarm source

To find all instances of an alarm source at and below a selected area:

- 1 On the navigation tree, select an area.
- 2 Click **Alarms** and select the **Actions**, **Enable/Disable**, or **Category** tab.
- 3 Select an alarm source from the list in step 2.
- 4 Click **View Selected Sources**.

NOTE You may be able to change settings that relate to the tab you selected.

To simulate an alarm

To test the setup of an alarm source and its *alarm actions* (page 72), you can simulate an alarm or its return-to-normal.

- 1 On the navigation tree, select the alarm source whose alarm you want to simulate.
- 2 Click **Properties > Alarm Sources** tab.
- 3 Click on an alarm point that is labeled as (BALM) or (CALM) and is enabled as a Potential Alarm Source (fifth column from the left).
- 4 In the dialog box that opens, select **Alarms** and then the **Enable/Disable** tab.
- 5 Check **Enable** next to **Alarm** or **Return to Normal**.
- 6 Click **Simulate** next to **Alarm** or **Return to Normal**.
- 7 Click **Accept**.

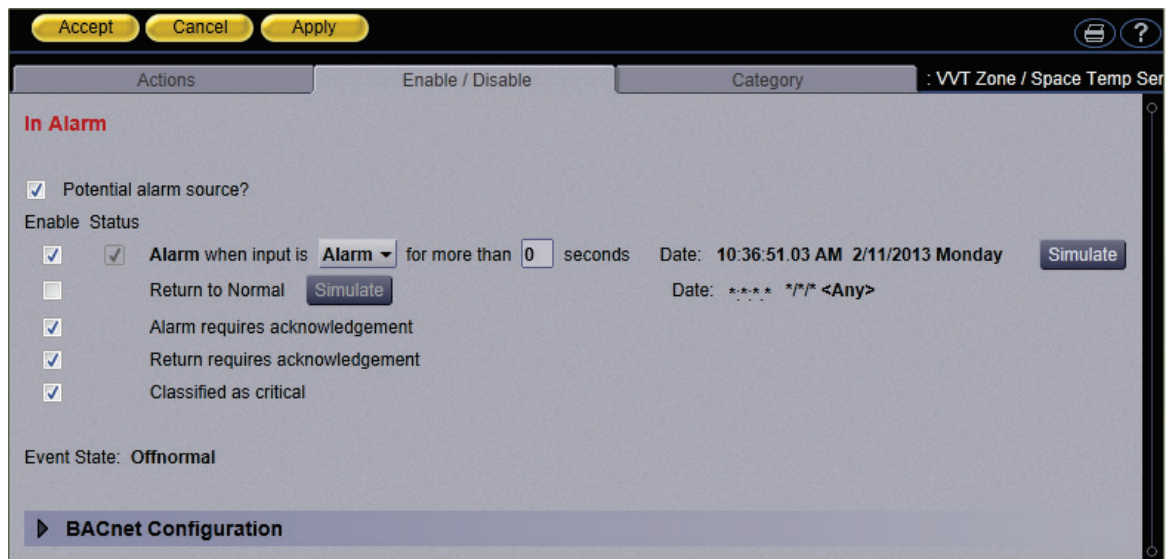

- 8 Select the controller on the navigation tree, then select the **Alarms > View** tab to see the alarm.

Alarm categories

Alarm categories sort related alarm sources and their alarms into groups such as HVAC Critical and Access Control General. Alarm categories let you:

- *View, acknowledge, or delete selected categories of alarms* (page 67) received by the i-Vu® application
- *Assign alarm actions* (page 72) to selected categories of alarm sources
- *Set up alarm sources* (page 79) in selected categories

Each alarm source is assigned to an alarm category in either the Snap application or in the i-Vu® interface.

To assign alarm sources to a category in the i-Vu® interface

- 1 On the navigation tree, select the area, equipment, or controller containing the alarm sources.
- 2 Click **Alarms**, then select the **Category** tab.
- 3 In step **1**, select the category that currently contains the alarm sources.
NOTE In step **1** and step **2**, **Ctrl+click**, **Shift+click**, or both to select multiple items, or check **Select All**.
- 4 In step **2**, select the alarm sources whose category you want to change.
- 5 In step **3**, select a category from the drop-down list, then click **Change**.
- 6 Click **Accept**.

Edit alarm messages

To edit the message for an alarm source

- 1 On the navigation tree, select the controller.
- 2 Select **Properties > Alarm Sources** tab and double-click the underlined name of point to open the microblock popup.
- 3 In the dialog, select **Alarms > Messages** tab.
NOTE **Sample Alarm Message** and **Sample Return Message** show the messages as they are currently defined.
- 4 Enter the edited message you want to appear in the field for **Alarm** or **Return**. You can add live data to the text by selecting *field codes* (page 83) from the **Append Field Code** list.
- 5 Click **Accept**.

Using field codes

Use field codes to insert live data into:

- The message on an alarm action
- Text displayed on the **Alarms** page > **View** tab
- Alarm information archived to a text file when an alarm is deleted

You can customize the setup of each of these items by appending field codes. For example, to have the message in an alarm action include the device that generated the alarm, append the Device field code to the action's message.

Formatting field codes

You can type a formatting command after a field code to format the field code in one of the following 3 ways:

- Format a number field code (Example: ##.##)
- Format a date/time field code (Example: MM/dd/yyyy hh:mm:ss)
- Left, right, or center align a field code and set the field width

A formatting command must have the following syntax:

```
$fieldcode%format_type:style$
```

Use the table below to determine the format_type and style for a formatting command.

	1 format_type	2 style	Example
To format a number	N	The actual formatting, such as ##.##. The basic format uses the pound sign (#) to represent a number. For more information, search the Internet for "customizing number formats with java".	To always round a setpoint value to two digits to the right of the decimal, the field code is: \$setpoint_value%N:##.##\$ For example, 78.9935 becomes 78.99.
To format date/time	D	The actual formatting, such as MM/dd/yyyy hh:mm:ss. For more information, search the Internet for "customizing date time formats with java".	To show the date and time when an alarm is generated in a format like 03/15/2004 10:50:43, the field code is: \$generation_time%D:MM/dd/yyyy hh:mm:ss\$
To set alignment and field width	L for left align R for right align C for center align	Indicate the field width by number of characters.	To left align the name of the device that generated the alarm and set the field width to 15 characters, the field code is: \$device%L:15\$

Using multiple formatting commands

You can type multiple formatting commands for a field code. For example, you can format a number and then set the alignment and field width. The syntax for multiple formatting commands is:

`$fieldcode%format_type1:style%format_type2:style$`

EXAMPLE To format the alarm date and time, center it and set the field at 20 characters, the field code is:
`$generation_time%D:MM/dd/yyyy hh:mm:ss%C:20$`

NOTE You must enter the date/time or number formatting command before the alignment/field width command.

Field Codes

Field Code Name	Field Code	Description
Acknowledge Operator	<code>\$acknowledge_operator\$</code>	The operator who acknowledged the alarm. EXAMPLE John Doe
Acknowledge Time	<code>\$acknowledge_time\$</code>	The time when the operator acknowledged the alarm. EXAMPLE Nov 12, 2012 6:46:31 PM
Alarm Category	<code>\$alarm_category\$</code>	The alarm category that the alarm is assigned to. EXAMPLE HVAC Critical
Alarm Priority	<code>\$alarm_priority\$</code>	The priority number associated with the alarm's priority (Off-Normal, Fault, or Normal) on the controller's Driver > Notification Class page.
Alarm Type	<code>\$alarm_type\$</code>	The alarm type of the alarm source. EXAMPLE CHANGE OF STATE
Character	<code>\$c\$</code>	A single ASCII character. Often used for form feeds and other printer escape sequences. EXAMPLE <code>\$C:65\$</code> displays A
Command Value	<code>\$command_value\$</code>	The commanded value from the alarm source. Valid only for alarm type COMMAND FAILURE. EXAMPLE 3
Control Program	<code>\$equipment\$</code>	The display name of the equipment where the alarm came from. EXAMPLE Chiller
Controller	<code>\$device\$</code>	The display name of the device where the alarm came from. EXAMPLE UPC Open
Dead Band	<code>\$deadband\$</code>	The deadband value from the alarm source. Valid only for alarm type OUT-OF-RANGE. EXAMPLE 5
Deletion Operator	<code>\$deletion_operator\$</code>	The operator who deleted the alarm. EXAMPLE John Doe
Deletion Time	<code>\$deletion_time\$</code>	The time the alarm was deleted. EXAMPLE Nov 12, 2012 6:46:31 PM

Field Code Name	Field Code	Description
Error Limit	\$error_limit\$	The error limit, from the alarm source. Valid only for alarm type FLOATING LIMIT. EXAMPLE 90
Event Values	\$event_values\$	Returns a string of alarm values associated with the alarm.
Exceeded Limit	\$exceeded_limit\$	The exceeded limit value from the alarm source. Valid only for alarm type OUT-OF-RANGE. EXAMPLE 90
Exceeding Value	\$exceeding_value\$	The exceeding value from the alarm source. Valid only for alarm type OUT-OF-RANGE. EXAMPLE 91
Fault	\$fault\$	The status of the fault condition from the alarm source. EXAMPLE True or false
Field Message	\$field_message\$	Text generated in the alarm by the controller.
Feedback Value	\$feedback_value\$	The feedback value from the alarm source. Valid only for alarm type COMMAND FAILURE. EXAMPLE 10
From State	\$from_state\$	The previous state of the alarm source. EXAMPLES NORMAL, FAULT, OFF NORMAL, HIGH LIMIT, LOW LIMIT
Generation Operator	\$generation_operator\$	The operator who forced the alarm to return to normal. EXAMPLE John Doe
Generation Time	\$generation_time\$	The time in the controller when the alarm was generated. EXAMPLE Nov 12, 2012 6:35:18 PM
In Alarm	\$in_alarm\$	The in alarm status from the alarm source. EXAMPLE True or false
Incident Closed Time	\$incident_closed_time\$	The time the alarm's entire incident group closed. EXAMPLE Nov 12, 2012 6:46:31 PM
Location Path	\$location_path\$	Displays the path display names from root to source. EXAMPLE Building B / Basement / VAV AHU B / SSP_STOP
Long Message	\$long_message\$	The formatted alarm long text displayed by double-clicking the alarm on the Alarms page.
Message Details	\$message_details\$	The message details displayed on the Alarms page View tab.
Message Prefix	\$message_prefix\$	The message prefix displayed on the Alarms page View tab.
Message Text	\$message_text\$	The message text displayed on the Alarms page View tab.
New State	\$new_state\$	The status of new state from the alarm source. Valid only for alarm type CHANGE OF STATE. EXAMPLE Alarm, Fault
New Value	\$new_value\$	The new value from the alarm source. Valid only for alarm type CHANGE OF VALUE. EXAMPLE 70

Field Code Name	Field Code	Description
Notification Class	\$notification_class\$	The notification class assigned denotes how the received alarm was generated. For example, if set to 1, the alarm would typically be sent to i-Vu® by Carrier controllers.
Object ID	\$object_ID\$	Object ID of the alarm source. EXAMPLE 5:26
Out of Service	\$out_of_service\$	The status of 'out of service' from the alarm source. EXAMPLE True or false
Overridden	\$overridden\$	The status of 'overridden' from the alarm source. EXAMPLE True or false
Program ID	\$program_id\$	The address of the control program that generated the alarm. BACnet program address format: device ID, program number EXAMPLE 2423101,1
Receive Time	\$receive_time\$	The time at the workstation when the alarm was received. EXAMPLE Nov 12, 2012 6:46:31 PM
Recipient Device ID	\$device_id\$	The device ID of the device where the alarm came from. EXAMPLE 8:2423101
Reference Path	\$reference_path\$	Path to alarm source. Available in all alarm actions. EXAMPLE #e_b_vav_ahu_b/ssp_stop
Reference Value	\$reference_value\$	The 'reference value' from the alarm source. Valid only for alarm type FLOATING LIMIT. EXAMPLE 83
Referenced Bitstring	\$referenced_bitstring\$	The value of the 'referenced bitstring' value from the alarm source. Valid only for alarm type CHANGE OF BITSTRING. EXAMPLE 1011011101101
RTN Time	\$RTN_time\$	The time when the alarm returned to normal. EXAMPLE Nov 12, 2012 6:46:31 PM
Setpoint Value	\$setpoint_value\$	The 'setpoint value' from the alarm source. Valid only for alarm type FLOATING LIMIT. EXAMPLE 72
Short Message	\$short_message\$	The formatted alarm short text.
Site	\$site\$	The display name of the site the alarm came from. EXAMPLE Kennesaw
Source	\$source\$	The display name of the alarm source microblock that generated the alarm. EXAMPLE SAT_HI
Source description	\$source:description\$	The Description field of the alarm source microblock that generated the alarm. EXAMPLE High Cooling Supply Air Temp

Field Code Name	Field Code	Description
Source Path	\$source:<path>\$	Substitute <path> with the path to the value you want to display. See <i>Defining i-Vu® paths</i> (page 174). Example to add text value: \$source:~equipment.display-name\$ NOTE You can use <i>Global Modify</i> (page 44) to get the path.
System Directory	\$system_dir\$	i-Vu® Pro only: The system folder name. EXAMPLE c:\<i-Vu_Pro_>x.x\webroot\world_corporation
To State	\$to_state\$	The current state of the alarm source. EXAMPLES NORMAL, FAULT, OFF NORMAL, HIGH LIMIT, LOW LIMIT

Trends

The i-Vu® system can read and store equipment status values over time and then display this information in a trend graph to help you monitor the equipment's operation.

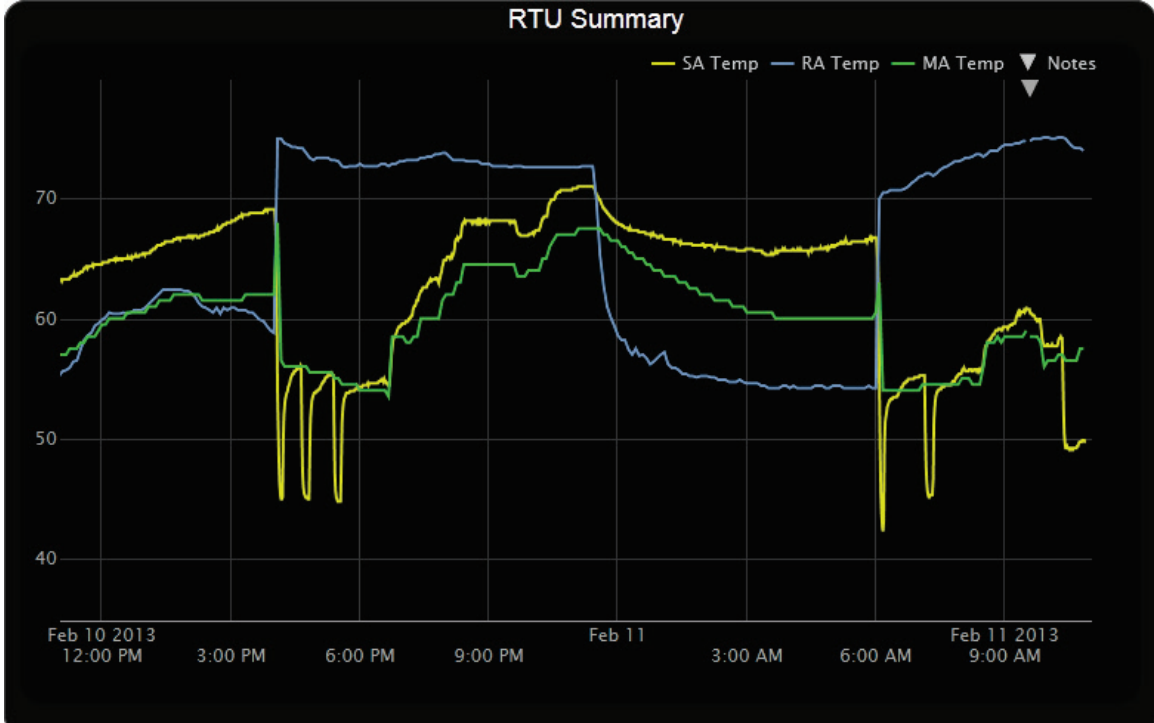

You can collect trend data for any point value in the i-Vu® system. The controller reads point values at intervals that you define and then stores that data in the controller for up to 7 days . A controller has limited memory for storing trend data, so you can set up historical trending to archive the trend data from the controller to the database.

A trend graph can display data from the controller and the database, or it can display only data stored in the database.

When the storage capacity of your system is running low from too much historical trend data, you will receive an error message. To create more storage space, go to the **Management Tool** (page 28) and click **Compress System**.

After you set up the desired points for trend data collection (page 89), you can:

- View built-in trend graphs that show a single point (page 90)
- Create custom trend graphs with multiple points (page 91)

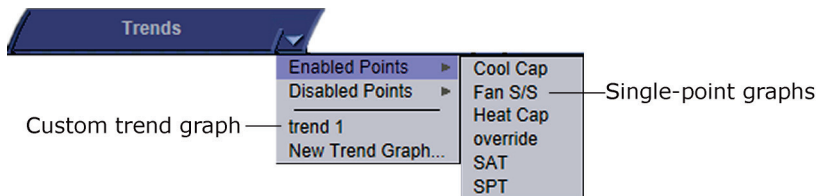

To collect trend data for a point

Before you can see a point's trend graph, you must enable trending for that point and then define how you want the controller to collect the point's data. This can be done in Snap or you can do it in the i-Vu® interface using the instructions below.

NOTE I/O microblocks have trending capability built-in, and you enable trend logging in the I/O microblock. Any other microblock value must have a trend microblock attached in the control program, and you enable trend logging of the value in the trend microblock.

To set up a point's trending in the i-Vu® interface:

- 1 On the navigation tree, select the equipment that has the point you want to trend.
- 2 Click the **Trends** button drop-down arrow, select **Disabled Points**, then select the point.
- 3 Click the **Enable/Disable** tab, then select **Enable Trend Log** to have the controller collect trend data.
- 4 Enter information in the appropriate fields. See table below.
- 5 Click **Accept**.



TIP You can set up all trends for a piece of equipment at once on the **Trend Sources** tab of the equipment's **Properties** page.

Field	Notes
Sample every _:._ (hh:mm)	Records the point's value at this interval. NOTES <ul style="list-style-type: none"> • Set this field to one minute or greater. • This setting should be longer than the CCN bus poll interval. To determine the poll interval: <ol style="list-style-type: none"> 1. In the Installer tree, right-click the device polling the CCN controller, and then select Driver Properties. 2. Go to Protocols > CCN. 3. Scroll down to the Program Status heading. 4. In the first row of the table, subtract the third column value from the fourth column value to get the poll interval.
Sample on COV (change of value)	This method records the point's value only when the value changes by at least the amount you enter in the COV Increment field. NOTE Use this method for a binary point or for an analog point that has infrequent changes in value.
Enable Trend Historian	Archives trend data to the system database.
Store Trends Now	Writes all trend data in the controller to the system database without having to enable trend historian.

Field	Notes
Keep trends for _ days	<p>Enter a number between 1 and 62 in this field to override the default number of days that trends for this point are stored. The trend storage default settings are:</p> <ul style="list-style-type: none"> • 62 days of override trends stored to accommodate Tenant Override Billing (available for i-Vu Plus only) • 7 days of all other system trends stored <p>NOTE Saving more than 62 days will affect system performance and could result in alarm messages instructing you to compress trend storage in the <i>Management Tool</i> (page 28). You can also create more space by using the next option Delete trend samples.</p>
BACnet Configuration	<p>The Object Name is a unique alphanumeric string that defines the BACnet object. Although the Object Name field can be edited, it is not recommended. The Notification Class is set to 1 to receive alarms generated by Carrier controllers.</p>

NOTE Run a *Trend Usage report* (page 95) to view trend data.

Viewing a built-in, single-point trend graph

- 1 On the navigation tree, select the equipment whose trend you want to view.
- 2 Click the **Trends** button drop-down arrow, select **Enabled Points**, and then select the graph you want to view.
- 3 Select the **View** tab. See *Using trend graphs* (page 93).

NOTE On the **Configure** tab, you can:

- Enable/disable the grid.
- Set the time range for the X axis. For example, enter 7 days to see the data for the last week.
- Turn off autoscaling so that you can define a range for the Y-axis
- Type a Y-axis label that will appear on the right side of the graph.

Creating a custom trend graph

When creating a custom trend graph, you can select up to 16 points. If you select more than 4 points or points with different units, the i-Vu® application splits the data into subgraphs. Each subgraph can show a maximum of 4 points with similar units.

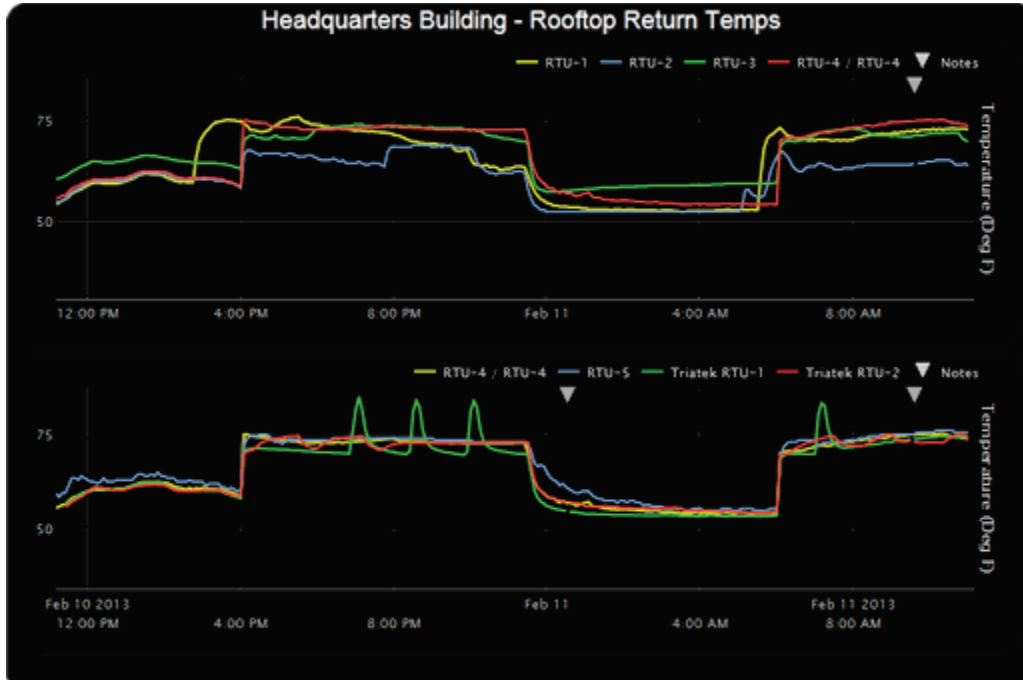

NOTE You must enable trending for points that you want to include in the custom trend graph. See *To collect trend data for a point* (page 89).

To create a custom trend graph

- 1 On the navigation tree, select the area or equipment where you want to see the graph.
- 2 Click the **Trends** button drop-down arrow, then select **New Trend Graph**.
NOTE If the **Trends** button does not have a drop-down arrow, the **New Trend Graph** page is already displayed.
- 3 In the tree on the **New Trend Graph** page, use **Ctrl+click** or **Shift+click** to select the points (16 maximum) that you want to see on a graph.
NOTE The tree shows only points that have trending enabled. See *To collect trend data for a point* (page 89).
- 4 Click **Save**.
- 5 Type a **Name** for the graph that will appear at the top of the graph and in the **Trends** button drop-down list.
- 6 Click **OK**.
- 7 Select:
 - The **View** tab to see the custom trend graph. See *Using trend graphs* (page 93).
 - The **Configure** tab to edit the trend graph. See *To edit a custom trend graph* (page 92).

To edit a custom trend graph

- 1 On the navigation tree, select the area or equipment where you created the graph.
- 2 Select the **Trends > Configure** tab. On this page, you can:
 - Change the name of the custom trend graph
 - Enable/disable the grid
 - Set the time range for the X axis
 - Edit a subgraph's Y-axis label that will appear on the right side of the graph
 - Turn off autoscaling so that you can define a range for the Y-axis
 - Add/delete subgraphs (see instructions below)
 - Add/delete points (see instructions below)
 - Change a point's name on the graph
 - Change a binary point's active/inactive text on the graph
 - Click **Delete Trend Graph** to delete the entire custom trend graph

To add a subgraph to a custom trend graph

- 1 Click **Add** below the **Subgraphs** list.
- 2 Type a Y-axis label.
- 3 Click **Add** below the **Points** list.
- 4 Select a point in the **Data source** tree.

NOTE The tree shows only points that have trending enabled. See *To collect trend data for a point* (page 89).
- 5 Repeat steps 3 and 4 to add up to 4 points to the subgraph.
- 6 Click **Accept**.

NOTE To delete a subgraph, select it in the **Subgraphs** list, click **Delete** below the list, and then click **Accept**.

To add a point to a subgraph

- 1 Select the subgraph in the **Subgraphs** list.
- 2 Click **Add** below the **Points** list.
- 3 Select a point from the **Data source** tree.

NOTE The tree shows only points that have trending enabled. See *To collect trend data for a point* (page 89).
- 4 Click **Accept**.

NOTE To delete a point, select the appropriate subgraph, select the point, click **Delete** below the **Points** list, and then click **Accept**.

Using trend graphs

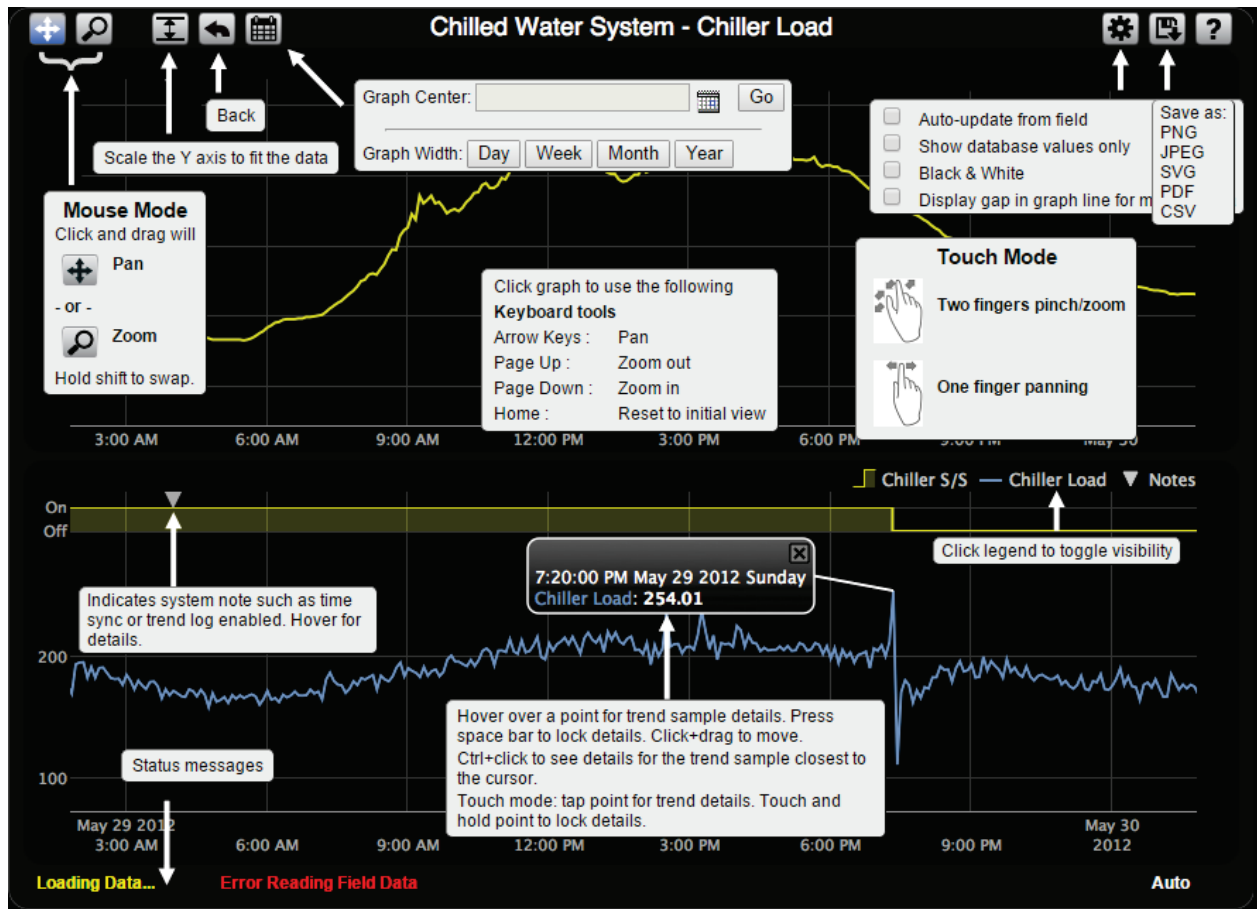

NOTES

- A gray triangle at the top of a graph indicates a note from the system. Hover your cursor on the triangle to see which of the following occurred:
 - Equipment received a time synchronization from its network router or from the i-Vu® application.
 - Trend Historian has been enabled or disabled.
 - Trend Log has been enabled or disabled.
 - The trend object ID of a third-party trend source has been changed. For information only, you do not need to do anything.
- Click  at the top of the i-Vu® page to print the graph. You may need to set your printer's orientation to Landscape.
- Toolbar options are also accessible by right-clicking a trend graph.
- You can check **Display gap in graph line for missing data** on an individual trend graph page, or you can go to the *System Options (or System Settings) > General tab* (page 25) to set this for all future trend graphs.

To view trend data in a spreadsheet program

You can save trend data as csv data that you can open in a spreadsheet program such as Microsoft® Excel®.

- 1 On the **Trends > View** tab, select  > **Save as CSV data**.
- 2 Save the data (.zip file) wherever you want. The .zip file contains the following:
 - A .csv file for each trend source (point). The filenames match the point names.
 - A **Combined** folder containing a file with the combined data for all of the graph's trend sources.
- 3 Open the .csv file in a spreadsheet program.

NOTES

- You will need to convert the data in the spreadsheet's **Time** column to a readable date/time format.
- If you use Microsoft® Excel® on a Mac and the converted date shows the wrong year, do the following:
 1. In Excel, go to **File > Options > Advanced**.
 2. Scroll down to the section **When calculating this workbook**, and then uncheck **Use 1904 date system**.

Reports

Use reports to monitor and troubleshoot your system. Your i-Vu® edition determines which of the following things you can do in the i-Vu® interface.

Reports feature	i-Vu® Standard	i-Vu® Plus
Run preconfigured reports	✓	✓
Run custom reports		✓
Schedule reports		✓

Preconfigured reports

The preconfigured reports shown in the **Reports** button drop-down list vary depending on which tree you selected.

In the **User** tree:

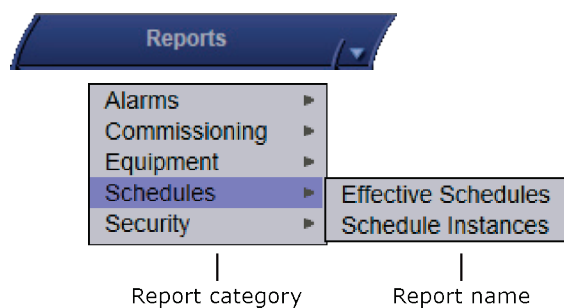

In the **Installer** tree:



A preconfigured report shows data for the selected tree item and all of its children.

This preconfigured report...	allows you to...
Alarms	
Alarm Actions	Create a summary of the information configured on the <i>Alarms > Actions</i> (page 72) tab.
Alarm Sources	Create a summary of potential alarm sources as configured on the <i>Alarms > Enable/Disable</i> (page 79) tab.
Alarms	View, sort, and filter the information on the <i>Alarms View</i> (page 67) tab.

This preconfigured report...	allows you to...
Commissioning	
Equipment Checkout	View the information on the Equipment Checkout tab of the equipment's Properties page during commissioning. Also, find equipment that has not been fully commissioned.
Test & Balance	<p>View the damper calibration parameters.</p> <p>Run this report after performing Test and Balance to upload all calibrations and resolve parameter mismatches.</p> <ul style="list-style-type: none"> Running the report at the equipment level of the navigation tree uploads to that location Running the report at the system or router level will upload to all equipment that contain one or more airflow microblocks. <p>CAUTION! After performing Test and Balance, you must run the Test and Balance report to upload the values from the controller to the i-Vu® application. You will lose all your calibrations if you download to the controller before running this report.</p>
Equipment	
Locked Values	<p>Find all locked points and locked values.</p> <p>NOTE Locks in the Airflow microblock are not reported.</p>
Network IO	Verify the programming and status of all network points—especially useful for commissioning controllers used for third-party integration.
Parameter Mismatch	Discover where your system has parameter mismatches that need to be resolved.
Point List	View the details of all points. Verify that all points have been checked out during commissioning. Also, create custom lists for other contractors. For example, create a list of BACnet IDs.
Trend Usage	Creates a summary of the information configured on the <i>Trends > Enable/Disable</i> (page 89) tab.
Schedules	
Effective Schedules	View all equipment that may be scheduled and the net result of all schedules in effect for a selected date and time.
Schedule Instances	Find every schedule with its location that is entered at and below a selected tree item. This report can help you discover newly added and conflicting schedules.
Security	
Location Audit Log	<p>NOTE You must have the Advanced Security package to run these reports.</p> <p>View chronological lists of changes, the operators that made them, and the reasons for the changes. This report includes changes such as property edits, downloads, driver changes, and view changes.</p> <p>Select the Options tab to choose whether to show the changes made by All Operators, System, Installer, or specific operators. You can show administration, system, and schedule group changes.</p>

This preconfigured report...	allows you to...
System Audit Log	View chronological lists of system-wide changes, the operators that made them, and the reasons for the changes. This report includes changes such as any change made on the tree, login/logout, and scheduled processes like deleting expired trends. Select the Options tab to choose whether to show the changes made by All Operators, System, Installer, or specific operators.
Network	
Controller Status	Discover network communication problems (shown as purple squares on the report) that need troubleshooting. The report also shows boot and driver version, download information, and if controller has 4.x or later driver, the report shows the serial number and Local Access port status.
Equipment Status	Display the thermographic color, status, and prime variable of each control program.

To run a preconfigured report

- 1 Select an item on the navigation tree.
- 2 Click the **Reports** button drop-down arrow, then select a report.
- 3 On the **Options** tab, define the layout and content of the report.

NOTES

- Changing the size and orientation of the printed page also changes the report layout on the **View** tab.
- To create a CSV (Comma Separated Values) file after you run the report, select **Support CSV text format**. See *To create a report PDF, XLS, or CSV file* (page 100).
- The current operator's report options are saved so that when that operator logs in again, the same options are used.

- 4 Click **Run**.

NOTE i-Vu® Plus and Pro only - Click **Schedule** to schedule the report to run on a recurring basis. See *Scheduling reports* (page 101).

Custom reports

i-Vu® Plus only - If custom reports have been created for your system, you can click the **Reports** button drop-down arrow, and then select **Report Manager** to see a list of all custom reports in your system.

In the Report Manager, you can:

- *Import a custom report(s) into your system* (page 99)
- *Export a report(s) to a file so that it can be imported into another system* (page 99)
- *Delete an existing report* (page 98)

NOTES

- A custom report may appear in the Report Manager but not appear in the Reports button menu because its only purpose may be to provide data to a table, chart, or color map on a Graphics page.
- To support upgraded systems, you can still create and access *legacy (v6.5 and earlier) custom reports* (page 103). These reports appear only in the **Reports** button drop-down menu, but not in the Reports Manager.

To run a custom report

i-Vu® Plus only

- 1 Select an item on the navigation tree where the report you want to run is accessible.
- 2 Click the **Reports** button drop-down arrow, and then select the report.
- 3 Optional: If the report was designed with variables, you can change the variables' values at the top of the page.

NOTE Click **Reset** if you want to change the variables back to the value that was assigned when the report was created.

- 4 Click **Run**.

NOTE Click **Schedule** to schedule the report to run on a recurring basis. See *Scheduling reports* (page 101).

To delete a custom report

i-Vu® Plus only

- 1 Click the **Reports** button drop-down arrow, and then select **Report Manager**.



TIP Click on the **Display Name** or **ID** heading to sort the column.

- 2 Select the report, and then click **Delete**.
- 3 Click **OK**.

To export or import a custom report

i-Vu® Plus only - You can export one or more reports from one system, copy them to another system, and then import the reports into the i-Vu® interface.

To export reports

- 1 Click the **Reports** drop-down arrow, and then select **Report Manager**.
- 2 Click **Export**.
- 3 Select the checkbox(es) for the report(s) that you want to export, or check **Select All**.
- 4 Click **Export**.

NOTE A single report is exported as a .table file. Multiple reports are exported as a .zip file.



TIP In the Report Manager or Export Report window, you can click on the **Display Name** or **ID** heading to sort the column.

To import reports

- 1 Copy the .table or .zip file to the computer where you are importing them.
- 2 In the i-Vu® interface, click the **Reports** drop-down arrow, and then select **Report Manager**.
- 3 Click **Import**.
- 4 Browse to the file that you are importing.
- 5 If a report ID that you are importing matches an existing report ID, select how you want to handle the situation:

Rename	Rename the report that you are importing.
Replace	Replace the existing report with the report you are importing.
Skip	Do not import the report with the duplicate name.

- 6 Click **Import**.

Custom report as the source for a Graphics page

i-Vu® Plus only – A custom report may appear in the Report Manager but not appear in the Reports button menu because its only purpose may be to provide data to a table, chart, or color map on a Graphics page.

For example, this report...

...supplies data to the chart and data table on this graphic

Name: Chart Example

Run Edit Schedule

Date Range	E1	E2	E3
Jun '16	7.0	7.0	5.0
Jul '16	9.0	4.0	3.0
Aug '16	1.0	5.0	2.0
Sep '16	9.0	5.0	3.0
Oct '16	7.0	2.0	3.0
Nov '16	8.0	7.0	5.0
Dec '16	4.0	0.0	6.0
Jan '17	3.0	5.0	1.0
Feb '17	9.0	7.0	3.0
Mar '17	8.0	0.0	9.0
Apr '17	0.0	5.0	6.0
May '17	6.0	8.0	2.0

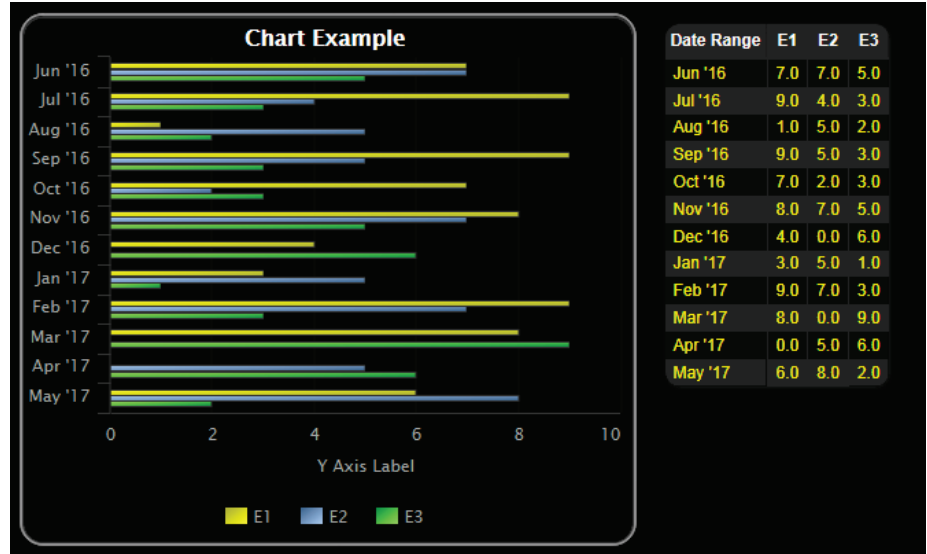

To create a PDF, XLS, or CSV file

These reports...	Can be output as...	Notes
v7.0 custom reports	<ul style="list-style-type: none"> A PDF file A CSV file 	
Preconfigured reports and v6.5 and earlier custom reports	<ul style="list-style-type: none"> A PDF file An XLS file A CSV file 	For a v6.5 and earlier CVS file, you must enable Support CSV text format on the Reports > Options tab before you run the report.

To output a file:

- 1 Run a report.
- 2 Click **PDF**, **XLS**, or **CSV** to download the file.

NOTE To create a CSV file when using Safari, see instructions below.

To create a CSV file when using Safari

- 1 Run a report.
- 2 Click **CSV**. A pop-up displays the results.
- 3 Select **File > Save As**.
- 4 In the **Format** field, select **Page Source**.
- 5 Add the .csv extension to the file name.
- 6 Select the save location in the **Where** field.
- 7 Click **Save**.
- 8 Close the popup.

NOTE If you need a digitally signed PDF to comply with 21 CFR Part 11, open the PDF in a program that supports digital signing such as the Adobe® Acrobat® application, then sign the PDF. The i-Vu® application does not support digital signing because 21 CFR Part 11 requires that the signature be added manually, not through an automated process.

Scheduling reports

i-Vu® Plus only - You can schedule a report so that it runs on a recurring basis. The report is saved as a file (PDF, CSV, or XLS), and you can choose to have it automatically emailed to someone.

NOTE You can also use the *Send E-mail alarm action* (page 76) to run any i-Vu® report, generate it as a PDF, HTML, XLS, or CSV file, and attach it to an email.

To schedule a report

- 1 Click the **Reports** drop-down arrow, and then select the report that you want to schedule.
- 2 Click the **Schedule** button.
- 3 Enter the information in each field.
- 4 Click **Accept**.

Fields	Notes
Description	Enter a brief description of the report or how this schedule will be used.
Operator	The report will be run based on the selected operator's privileges.
Run report	Define when the report will run by selecting options in the drop-down lists.
At __: __	Enter the time of day that you want the report to run.

Fields	Notes
Save report as	v7.0 reports can be output as a PDF or CSV file. Preconfigured reports and v6.5 reports can also be output as an XLS file. Select the type of report file that you want.
Keep latest	Enter the number of files and Schedule History entries that you want to keep for this report. As a new file or entry is saved, the oldest one is deleted.
Email report	Enter the information needed to email the report each time it runs. NOTE For the i-Vu® application to email a report, you must define the Email Server configuration on the System Options > <i>General tab</i> (page 25).

To manage scheduled reports

Click the **Reports** drop-down arrow, and then select **Scheduled Reports**. The table shows any report that was scheduled on the report's page.

Select a schedule and then click...	To...
Edit	Change the report's schedule in the Schedule Editor. NOTE You can also double-click a schedule in the table to open the Schedule Editor.
View History	See when the report ran. Click PDF , CSV , or XLS in the Results column to download the report that was produced. NOTE The XLS option is not available for v7.0 custom reports.
Delete	Remove the schedule. This removes its history and all associated files.

If a report fails

The table below will show a red X and a system alarm will be generated.

Scheduled Reports					
Report Name ▼	Description	Location	Last run	Next run	Schedule ID
Trend Sample	Trend Sample	E1	X 12/11/2017 1:45 PM	12/13/2017 1:45 PM	14
Trend Sample 13	Trend Sample 14	E1	X 12/11/2017 1:47 PM	12/13/2017 1:47 PM	15

Select the schedule in the table above, and then click **View History**. Hold the cursor over the word **Failure** to see hover text describing what failed.

Working with legacy (v6.5 and earlier) custom reports

i-Vu® Plus only - Although the i-Vu® Plus v7.0 application has a new method of managing reports, you can still create or edit the following reports that were available in i-Vu® v6.5 and earlier systems. These reports will be accessible from the **Reports** button drop-down list, but not the Report Manager.

This report...	allows you to...
Equipment Summary	<p>View the following information for equipment at or below the location where the report was created:</p> <ul style="list-style-type: none">• Color• Active alarm• Locked values• Current value of selected points• Combined schedule <p>See <i>To create an Equipment Summary report</i> (page 103).</p>
Equipment Values	<p>Compare point information. See <i>To create an Equipment Values report</i> (page 104).</p>
Trend Samples	<p>View trend values for a particular time frame. See <i>To create an Trend Samples report</i> (page 106).</p>

NOTE You can schedule a report to run on a recurring basis. See *Scheduling reports* (page 101).

To create an Equipment Summary report

An **Equipment Summary** report can provide the following information for equipment at or below the location where the report is created.

- Color
- Active alarm
- Locked values
- Current value of selected points
- Combined schedule

To create an Equipment Summary report:

- 1 On the navigation tree, select the location where you want to view the report.
- 2 Click the **Reports** button drop-down arrow, then select **Add Legacy Report**.
- 3 Select **Equipment Summary**.
- 4 Type a name for the report.
- 5 Click **Create**.
- 6 Define the **Title**, **Page Size** and orientation, and the **Maximum number of rows**.
- 7 Select or clear the **Optional Sections** checkboxes as needed.
- 8 Optional: Select **Include only specific control programs at or below this location**, then type the names of the control programs.



- 9 Select **Available Points** that you want to include in the report. Use **Ctrl+click**, **Shift+click**, or both to select multiple items.
- 10 Click **Add**.
- 11 Click **Accept**.
- 12 Click **Run**.

NOTE To run this report later, go to the location where the report was created. Click the **Reports** button drop-down arrow, select the report, then click **Run**.

To create an Equipment Values report

An **Equipment Values** report allows you to compare point information.

To create an Equipment Values report:

- 1 On the navigation tree, select the location where you want to view the report.
- 2 Click the **Reports** button drop-down arrow, then select **Add Legacy Report**.
- 3 Select **Equipment Values**.
- 4 Type a name for the report.
- 5 Click **Create**.
- 6 Click  next to **Rows**.
- 7 On the selection tree, select the pieces of equipment you want to view in the report. (Use **Ctrl+click**, **Shift+click**, or both to select multiple items.) Then click **Add**.
- 8 Optional: Select the **Highlight alternate rows** checkbox to make the report easier to analyze.
- 9 Click **Next** or  next to **Columns**.
- 10 Verify or change the report **Title**, **Page units** of measure for defining column widths, and **Outer border** characteristics.
- 11 Select a column in the report preview.
NOTE The selected column is light blue.
- 12 Under **Column Header**, define how you want the column header to look.
- 13 Under **Column Data**, define the data you want in the column and how you want it to look. See table below.
NOTE Select **General** from the **Format** drop-down list unless you want to define the number of places to the right of the decimal point for the displayed value.
- 14 Optional: Use the **Add**, **Delete**, and arrow buttons below the report preview to manipulate the columns.
- 15 Optional: Click  next to **Page** to change the page size and orientation.
NOTE Changing the size and orientation of the printed page also changes the report layout on the **View** tab.
- 16 Click **Accept**.
- 17 Click **Run**.

NOTE To run this report later, go to the location where the report was created. Click the **Reports** button drop-down arrow, select the report, then click **Run**.

Type of Column Data		
Point		Displays point data in the column.
	Display	Select the property to show in this column.
	Data is named differently in some control programs	Select this checkbox if similar points have different names in different control programs. Then add each of the names to the Name to use list. For example, if a point is named Zone Temp in one control program and Zone Temperature in different control program, add both names to the list.
	Point to use	Select the name of the point to show in the column.
Trend Sample	Display	Select First, Minimum, Maximum, or Last recorded trend value.
	Data is named differently in some control programs	Select this checkbox if similar points have different names in different control programs. Then add each of the names to the Name to use list. For example, if a point is named Zone Temp in one control program and Zone Temperature in different control program, add both names to the list.
	Trend to use	Select the name of the point to show in the column.
	Set	Click to have all columns in the report use the same time range.
	Time Range	Select the time range to run the report for.
	Trend Calculation	Display
	Data is named differently in some control programs	Select this checkbox if similar points have different names in different control programs. Then add each of the names to the Name to use list. For example, if a point is named Zone Temp in one control program and Zone Temperature in different control program, add both names to the list.
	Trend to use	Select the name of the point to show in the column.
	Set	Click to have all columns in the report use the same time range.
	Time Range	Select the time range to run the report for.
Control Program	Display	Select Color, Display Name, Display Path, Notes, Prime Variable, or Reference Name to show in the column.
Expression	Data is named differently in some control programs	Select this checkbox if similar points have different names in different control programs. Then add each of the names to the Name to use list. For example, if a point is named Zone Temp in one control program and Zone Temperature in different control program, add both names to the list.

Type of Column Data

Expression

Type the path relative to the current control program. The path must return a string value. See *Defining i-Vu® paths* (page 174) for more information on paths.

To display the **Notes** on an equipment's **Properties** page, type `.notations` in this field.



To create a Trend Samples report

A **Trend Samples** report provides trend values for a particular time frame.

To create a Trend Samples report:

- 1 On the navigation tree, select the location where you want to view the report.
- 2 Click the **Reports** button drop-down arrow, then select **Add Legacy Report**.
- 3 Select **Trend Samples**.
- 4 Type a name for the report.
- 5 Click **Create**.
- 6 Select a **Time Range** from the drop-down list, then refine that option by selecting an option from the drop-down list(s) to the right.
- 7 Define the trend data.

NOTES

- **Calculate values for missing samples** calculates a value based on the 2 closest values to the time interval.
 - **Find the closest sample** displays the value closest to the time interval selected.
- 8 Optional: Select the **Highlight alternate rows** checkbox to make the report easier to analyze.
 - 9 Click **Next** or  next to **Columns**.
 - 10 Verify or change the report **Title**, **Page units** of measure for defining column widths, and **Outer border** characteristics.
 - 11 Select a column in the report preview.
NOTE The selected column is light purple.
 - 12 Under **Column Header**, define how you want the column header to look.
 - 13 Under **Column Data**, select the source of the trend data and how you want the data to look.
NOTE Select **General** from the **Format** drop-down list unless you want to define the number of places to the right of the decimal point for the displayed value.
 - 14 Optional: Use the **Add**, **Delete**, and arrow buttons below the report preview to manipulate the columns.
 - 15 Optional: Click  next to **Page** to change the page size and orientation.
NOTE Changing the size and orientation of the printed page also changes the report layout on the **View** tab.
 - 16 Click **Accept**.

17 Click **Run**.

NOTE To run this report later, go to the location where the report was created. Click the **Reports** button drop-down arrow, select the report, then click **Run**.

To save a v6.5 or earlier custom report's design

You can save the design of an Equipment Values report or a Trend Samples report for reuse in another location. Or, you can create a library of different report designs to pull from as needed.

To save a report's design

- 1 Create the *Equipment Values* (page 104) or *Trend Samples* (page 106) report.
- 2 On the **Reports > Design** tab, click the **Save Report Design** button.

NOTE The .reportdesign file includes the report name. If you save multiple report designs in your system, each of those reports must have a unique name.

To use the report design at a different location in the system

- 1 Select the location in the navigation tree.
- 2 Select **Reports > Add Legacy Report**.
- 3 In step **1**, select **Report design**, then select the report name in the drop-down list.
- 4 In step **2**, type a report **Name**.
- 5 In step **3**, click **Create**.

To edit or delete a custom report

- 1 Select the item on the navigation tree where the report was created.
- 2 Click the **Reports** button drop-down arrow, then select the report you want to edit or delete.
- 3 Do one of the following on the **Design** tab:
 - o Edit the report, then click **Accept**.
 - o Click the **Delete Report** button, then click **OK**.

Setting up devices in the i-Vu® application

Setting up i-Vu® Open or i-Vu® XT devices in the i-Vu® application

These procedures differ for CCN devices. See *Setting up CCN devices in the i-Vu® application* (page 115).

From the system level in the navigation tree, select **Devices** page > **Manage** tab to:

- *Search the network to populate the system with BACnet routers and controllers* (page 108)
- *Upload control programs, drivers, graphics, and screen files* (page 108)
- *Build, edit, and arrange the navigation tree for the **User** view* (page 151)
- *Perform downloads to individual or multi-selected controllers* (page 148)

Find and upload routers and controllers

- 1 Select the System in the navigation tree.
- 2 On the **Devices** page > **Manage** tab, click **Find Devices** to discover your routers.
- 3 Once routers are found, select one router at a time in the left-hand navigation tree and click **Find Devices** again.
- 4 Once controllers are found, you must upload content from the routers and controllers. Select one or more in the list on the **Manage** tab and click **Upload All Content** to upload drivers, graphics, touch files, and control programs to the i-Vu® application. Use **Ctrl+click**, **Shift+click**, or both to select multiple items.

NOTE If **Show Control Programs** is checked, all control programs are listed. If you have multiple control programs in one controller, you will see every control program in the list. If it is not checked, the list only shows the individual controllers and their model. The same information is uploaded, this option just controls what you see on the **Manage** tab and you can switch at will.

- 5 Click **OK** when you see the message **This will upload all content for the controller. Are you sure you want to do this?** When complete, a check mark under **Status** indicates a successful upload.

NOTES

- If an error message appears, click on the message to view an explanation.
- Uploading can be time consuming, especially for multiple controllers. You may want to create the navigation tree for the **User** view while waiting. See *Create navigation tree*. (page 151)
- The MAC address shows to the left of the controller name in the **Installer** navigation tree only. Controllers may show multiple equipment listings with the same MAC address, based on control programs downloaded from EquipmentBuilder or Snap.
- To view the driver names after uploading, select the **Advanced** tab or right-click the controller in the navigation tree and select **Driver Properties** or **Module Status**.



TIPS

- Click the **I** symbol  in the upper left corner to display the status of the latest operation.
- Status messages are color coded as follows:
 - Red - reports an error
 - Blue - requires action
 - Green - indicates an upload or download is in process

Verify network and device settings



CAUTION The i-Vu® application automatically assigns a **BACnet Network IP number** and the **Server Device Id** for the application. Do **not** change these addresses unless absolutely necessary!

NOTE If you have more than 99 routers, you must set your own addresses.

To change an address:

- 1 Select the system, a router, or the USB network in the navigation tree and then go to the **Devices** page > **Advanced** tab.
- 2 Click **Accept** after making changes.

Verify and edit the following fields only as necessary.

System level

- **BACnet/IP network** — default is 1600 (The maximum number allowed is 65,534)
NOTE Typically, you should not need to change this.
- **Server Device Id** — address of the i-Vu® web server (default is 169999)
- **Communications Time-out (In milliseconds)** — increase this value only if downloads to controllers or routers fail with communication time-out errors.
- **Communication Retries** — default is 3
- **Group Cache Controller** — select the peer caching router. See *To set up peer caching for details* (page 155).

- **BACnet Discovery** — locates all accessible BACnet networks, BACnet devices, and BACnet objects on a BACnet network. Typically used to integrate BACnet third-party devices into the i-Vu® system. See *To discover third-party BACnet networks, devices, and objects* (page 128).

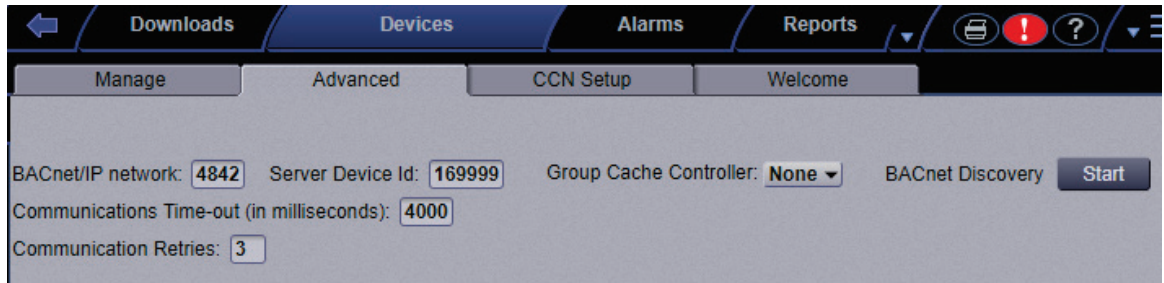

Router level

- **Router to Arcnet network** and **Auto-Assign**
- **Router to MS/TP network** and **Auto-Assign**
- **Device Identifier**

USB Network

- **Baud Rate** - recommended rate is 76,800
- **Router to Network**

Working with control programs

In the navigation tree, you can double-click the controller, or right-click and select **Configure**, then select one of the following options:

- **Edit Existing** - Downloads files to your computer for programmable controllers to edit in Snap or EquipmentBuilder
- **Add New** - Obtains files for the i-Vu® application to add to a blank controller or to replace an existing control program
- **Delete Unused** - Deletes unused control programs

Update - Go to **System Options > Update** tab to install .update files or to update the SAL library version. See *Update the equipment library* (page 162) for complete instructions.

You can use EquipmentBuilder or Snap to create your control programs (.equipment files).

- EquipmentBuilder can also produce a graphic (.view file), screen file, and a sequence of operation, based on the equipment options you select.

- If using Snap, you must create your graphics separately in ViewBuilder. See Snap Help for detailed instructions on creating a custom control program.

After creating your control program, load it into i-Vu® and download it into the controller. See *Add or delete a custom control program to a controller and to i-Vu®* (page 113).

Reload, create, or edit a control program in EquipmentBuilder or Snap

If the control program has already been uploaded to the i-Vu® application and loaded into the programmable controller, you must save it to your computer to be able to edit it in EquipmentBuilder or Snap.

To reload a control program

In the navigation tree, right-click the controller and select **Reload Control Program**. Reloading updates all instances of a control program throughout the system and marks the controller(s) for an All Content download.

To create your control program in EquipmentBuilder

- 1 Start EquipmentBuilder. (Windows **Start > All Programs > i-Vu Tools x.x**)
- 2 Click **Create Equipment** and then click **Next**.
- 3 Select the .sal library from the **Library:** drop-down list.
- 4 Select the equipment type from the list and click **Next**.
- 5 In the **Equipment Name** field, edit the name, if desired.
NOTE Your name must not exceed 21 characters.
- 6 Select options on the **Summary** tab and, if applicable, edit setpoints on the **Sequence** tab.
NOTE The **Points** and **Sequence** tabs change based on your choices on the **Summary** tab.
- 7 Click **Next**.
- 8 Check the files you wish to generate from the list.
- 9 Check to select saving your control program files to a folder of your choice or a folder linked to a system.
- 10 Click **Next**.

To save the control program you want to edit

- 1 Double-click the programmable controller in the navigation tree, or right-click and select **Configure**.
- 2 Select the control program you want to edit in the **Control Program** drop-down list.
- 3 Click **Edit Existing** in the **Control Programs** box. A new dialog window appears.
- 4 Save the file to a location of your choice.
- 5 Click **Close**.

To edit the control program in EquipmentBuilder or Snap.

- 1 Click Windows **Start < All Programs > I-Vu Tools x.x > EquipmentBuilder** or **Snap**.
- 2 In EquipmentBuilder, click **Open Equipment** or, in Snap, select **File > Open**.
- 3 Open the .equipment file that you saved and edit it.
- 4 Save your revised control program with a different name.
- 5 Open the i-Vu® application.
- 6 Double-click the programmable controller in the navigation tree, or right-click and select **Configure**.
- 7 Click **Add New** in the **Control Programs** box. A new dialog window appears.
- 8 Browse to your edited control program and click **Continue**. When message appears **File added successfully**, click **Close**.
- 9 Click **Close** again.

NOTE If you change a control program in the Snap application and it does not display correctly in the i-Vu® interface, **Ctrl+right-click** the i-Vu® action pane, and then select **Refresh**.

Apply these changes to the controllers

- 1 Select the router in the navigation tree.
- 2 On the **Devices** page > **Manage** tab, select any controllers with a **File Mismatch** error message. (**CTRL+click** or **Shift-click** to multi-select.)
- 3 Right-click and select **Download All Content**. You now have the updated control programs, graphics, drivers, and screen files in your routers and controllers.

To change the control program for all controllers of one type when adding new controllers

- 1 Select the **Devices** page > **Manage** tab
- 2 To upload one or more controller's graphics, screen files, and control programs, select one or more controller (**Shift-click** or enable **Select all**) and click the **Upload** button.

To change the control program for all controllers of one type when updating the current library

See *Update the equipment library* (page 162).

NOTE If you change a control program and it does not display correctly in the i-Vu® interface, **Ctrl+right-click** the i-Vu® action pane, and then select **Refresh**.

Add or delete a custom control program

To save time when testing custom control programs, you can use **DEBUG MODE** (page 174) in the i-Vu® interface for one controller at a time.



CAUTION Never leave your i-Vu® system without unchecking **DEBUG MODE** first and then downloading all content. The source files are not in the controller until you complete both steps.

To add a new control program to a programmable controller

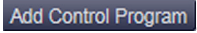
- 1 Select the router in the navigation tree.
- 2 Select **Devices > Manage** tab.
- 3 Select the controller in the list on the page.
- 4 If you are adding a new control program, click the **Add Control Program** button . A dialog window appears.
- 5 Enter a name for your control program in **Display Name** and select your controller in the **Controller** drop-down list.

NOTES

- If you already have the maximum number of control programs for a controller, it will not appear in the list.
 - Optional: You can change the control program's **Reference Name** if needed.
- 6 Do one of the following:

If the control program is...

In the **Control Program** drop-down list Select the control program.

- Not in the **Control Program** drop-down list
- a. Click **Add New**.
 - b. Browse to select the control program.
 - c. Click **Open**.
 - d. Click **Continue**.
 - e. Click **Close**.
-

- 7 To upload a graphic, click **Add New** under **Views** and browse to your .view file.
- 8 Click **Continue**. When message appears **File added successfully**, click **Close**.
- 9 Click **Close** again.
- 10 Right-click on the programmable controller in the controller list and select **Check Status** from the list. The status of the controller should say **File Mismatch**.
- 11 Click the **Download All Content** (page 148) button.

NOTE If you need to edit the **Object Instance**, right-click the control program in the navigation tree and then select **Configure**. Click  next to the field for additional information.

To delete a single control program in a programmable controller

- 1 Select the router in the navigation tree.
- 2 Right-click the the desired controller/control program in the list on the **Devices** page > **Manage** tab and click **Delete Selected** from the list.
- 3 The message appears **Do you wish to remove a controller and all its descendants?** Click **OK**.
IMPORTANT! The process is not finished until you complete the following steps.
- 4 Highlight the programmable controller in the controller list again, and select **Check Status**. The status of the controller should say **File Mismatch**.
- 5 Click **File Mismatch** and click the **Download** button. This deletes the files from the controller.

To delete all control programs in a programmable controller

- 1 Select the router in the navigation tree.
- 2 Right-click the desired controller/control program in the list on the **Devices** page > **Manage** tab and select **Delete Programs**. Click **OK** when the following message appears **This will delete all programs in this controller. Are you sure?**
IMPORTANT! The process is not finished until you complete the following steps.
- 3 Highlight the programmable controller in the controller list again, and select **Check Status**. The status of the controller should say **File Mismatch**.
- 4 Click **File Mismatch** and click the **Download** button. This deletes the files from the controller.

To edit a control program on an i-Vu® Pro client

On an i-Vu® client, you can get a copy of a control program from the server, edit it, then put it back on the server.

To get the control program

- 1 In the navigation tree, right-click the equipment, then select **Configure**.
- 2 In the **Control Programs** section, click **Edit Existing**.
- 3 Click **Save**.
- 4 Browse to the folder you want to put the file in.
- 5 Click **Save**.
- 6 Click **Close**.
- 7 Click **Close** again.

To put the edited control program back on the server

- 1 In the navigation tree, right-click the equipment, then select **Configure**.
- 2 In the **Control Programs** section, click **Add New**.
- 3 Browse to select the control program.

- 4 Click **Open**.
- 5 Click **Continue**.
- 6 Click **Close**.
- 7 Click **Close** again.

Setting up CCN devices in the i-Vu® application

Connect to the Gateway on the **Devices > CCN Setup** tab.

Select the Gateway in the navigation tree > **Devices > CCN Discovery** tab to:

- *Scan the network to populate the system with CCN device managers and controllers* (page 115)
- *Download control programs, drivers, graphics and BACview files* (page 115)
- *Build, edit, and arrange the navigation tree for the **User** view* (page 151)
- *Perform downloads to individual or multi-selected controllers* (page 148)

NOTES

- On the **System Options > General** tab, you can check to **Use metric units for CCN tables and control programs**.
- You must use Network Service Tool to change addresses.

To find and download CCN devices

If you are using:

- A Carrier® ChillerVu™ as a CCN device, follow all of the steps on this page
- An i-Vu® CCN Router or i-Vu® Link, start with **Connect to a CCN system**



Connect to a Carrier® ChillerVu™

- 1 In the navigation tree, from the system level, go to the **Devices** page > **Manage** tab.
- 2 Click **Find Devices**.
- 3 Select the Carrier® ChillerVu™ in the list on the **Manage** tab and click **Upload All Content**.
- 4 You must set the Carrier® ChillerVu™ to be the Gateway or Bridge.
 - a) Right-click the router, select **Driver Properties**.
 - b) Expand **Protocols** and select **CCN**.
 - c) Select the correct baud from drop-down list.
 - d) If it is the Gateway, select **CCN Gateway** for **Device Type**. If it is a Bridge, select **CCN Bridge**.
 - e) Fill in **Element** number.
- 5 Continue with the steps below.

Connect to a CCN system

- 1 In the i-Vu® interface, select the system in the navigation tree.
- 2 On the **Devices** page > **CCN Setup** tab, enter your CCN Gateway IP address and click **Connect to Gateway**.
NOTE If the server has more than 1 NIC, type the IP address the server will use to connect to controllers.
- 3 After connecting to the Gateway, select it in the navigation tree.
- 4 On the **Devices** page > **CCN Discovery** tab, verify that **Discover Tables** is checked.
NOTE The scanning time for discovering tables increases based on the number of devices. You may choose to discover tables at a later time for a faster scan.
- 5 Enter the **Bus** and **Element** ranges that encompass all your devices.
NOTE Depending on your number of devices, it could be faster to scan several small ranges.
- 6 Click **Start Scan**. When the process is complete, a message appears showing the number of control programs found.
NOTES
 - If the scan does not begin, wait a minute and try again. There may be a delay when first starting the system.
 - If an error message appears, click on the message to view an explanation.
- 7 Click **Download CCN** to download the control programs, drivers, and parameters.
NOTE This process can be time consuming. While waiting, you may want to create the navigation tree for the **User** view. See *Create navigation tree*. (page 151)
- 8 If you have programmable controllers and want to add a .equipment file made in EquipmentBuilder or Snap, see *Assign and download a custom equipment file* (page 116).

TIPS

-  indicates you need to download the device by clicking **Download CCN**.
- Click  to view a log of activity on the **Devices** page in the current session. **Copy to Clipboard** lets you copy the text to paste it into another application.
- Status messages are color coded as follows:
 - Red - reports an error
 - Blue - requires action
 - Green - indicates an upload or download is in process

To assign and download a custom CCN equipment file

To add a custom control program to the list of available programs:

- 1 In the i-Vu® navigation tree, right-click the controller you want to associate the equipment or control program with.
- 2 Either double-click the controller in the navigation tree, or right-click and select **Configure** in the list.
- 3 Enter the **Display Name**.

- 4 To add a control program to the list of possible .equipment files in i-Vu®, do one of the following:

If the control program is...

- | | |
|--|---|
| In the Control Program drop-down list | a. Select the control program that you generated in EquipmentBuilder or Snap.
b. Click Accept . |
| Not in the Control Program drop-down list | a. Click Add New .
b. Browse to select the equipment file.
c. Click Open .
d. Click Continue .
e. Click Close .
f. Click Close again. |
-

- 5 To add a graphic, do one of the following:

If the graphic is...

- | | |
|--|--|
| In the Views Available list | a. Select the graphic, then click Attach .
b. Click Accept . |
| Not in the Views Available list | a. Click Add New .
b. Browse to select the view file.
c. Click Open .
d. Click Continue .
e. Click Close .
f. Click Close again. |
-

- 6 When finished, select the Gateway in the navigation tree and select the **Devices** page.
7 Click **Download CCN** to finalize your changes.

For additional pieces of equipment controlled by your Universal Controller/Comfort Controller (expansion controllers)

- 1 In the navigation tree, select the device manager that the controller is associated with.
- 2 Select the **Devices** page and click **Add Control Program**.
- 3 Enter the **Display Name**.
- 4 Select the controller or Gateway that you want to associate the new equipment with. If you select **CCN Controller**, enter the Bus and Element number of the controller.
- 5 Do one of the following:

If the control program is...

- | | |
|--|--|
| In the Control Program drop-down list | a. Select the control program that you generated in EquipmentBuilder.
b. Click Accept . |
| Not in the Control Program drop-down list | a. Click Add New .
b. Browse to select the view file.
c. Click Open .
d. Click Continue .
e. Click Close .
f. Click Close again. |
-

- 6 Add a graphic or, if finished, select the Gateway in the navigation tree and, on the **Devices** page, click **Download CCN** to finalize your changes.
- 7 To add a graphic, do one of the following:

If the graphic is...

- | | |
|--|--|
| In the Views Available list | a. Select the graphic.
b. Click Accept . |
| Not in the Views Available list | a. Click Add New .
b. Browse to select the view file.
c. Click Open .
d. Click Continue .
e. Click Close .
f. Click Close again. |
-

- 8 When finished, select the Gateway in the navigation tree and, on the **Devices** page, click **Download CCN** to finalize your changes.

To view an equipment's CCN tables

- 1 In the navigation tree, select the equipment.
- 2 Click  next to the equipment to expand it.
- 3 Select the table you want to view.

Working with Universal and Comfort Controllers (CCN)

Universal Controllers (UC) and Comfort Controllers (CC) are assigned a generic equipment and view file, which have setpoint control, but no additional pre-mapped I/O. To generate additional I/O points for graphic display, you must use EquipmentBuilder to create custom equipment files that support your application. These files map the CCN variables to i-Vu® BACnet points.

In EquipmentBuilder, you can create **CCN Values Only**, **Read Integration**, or **Link Integration** custom equipment for UC/CC's that are tailored for your specific application.

EquipmentBuilder can also create some stand-alone applications for Consumable Reports for:

- **Energy Meters**
- **Non-linear flow meters**
- **Energy (BTU) consumption**
- **Equipment Runtime**

NOTE You can add these options to **CCN Values Only** and **Link Integration** custom equipment and require mapping just the points to be monitored.

Once the equipment files and the view file are *added to a device in the i-Vu® interface* (page 116), you can assign these points to custom graphic elements created in ViewBuilder.

Because CC's will likely control multiple pieces of HVAC equipment, expansion controllers associated with CC's must be added to the i-Vu® **Devices** page (select the Gateway in the navigation tree.) You can control separate setpoints and schedules for multiple physical equipments from a single CC. The expansion controllers support the additional equipment and view files required for these systems.

Create custom equipment files in EquipmentBuilder for UC/CC's that link only to CCN points

You create an equipment file in EquipmentBuilder for the UC/CC, which maps the I/O points required for one or more applications. Once you have created the files, you can associate the linked I/O points with ViewBuilder graphics.

NOTE To have a **Prime Variable**, (a temperature displayed in a color oval when the UC/CC is shown in a site or area equipment list), you must select the **Schedule and Setpoint** option when creating the equipment file.

- 1 Start EquipmentBuilder. (Windows **Start** > **All Programs** > **i-Vu_Tools_x.x**)
- 2 Click **Create Equipment**.
- 3 Select i-Vu EquipmentBuilder SAL from the Library drop-down list.
- 4 Select equipment type: **Custom Equipment** > **CCN Values Only**.
- 5 Click **Next**.
- 6 In **Equipment Name**, type a name for the custom equipment (i.e., Hot Water system).
- 7 Enable **English** or **Metric** units.
- 8 Select options from the drop-down lists.
- 9 Select **Schedule and Setpoint** in the first drop-down list to use the setpoint slidebar graphic in the i-Vu® interface and to have a **Prime Variable** (a temperature displayed in a color oval when the UC/CC is shown in a site or area equipment list).
- 10 Click **Next**.
- 11 Choose the type of element, quantity, and click .

Add Elements to your application

NOTE Elements are a collection of input/output points that perform a specific operation. The input/output point that is reading or writing to the UC/CC is called a CCN point.

The available Elements that you can add to your custom equipment in EquipmentBuilder are:

Point type	Used for
Read CCN Point	Reading an analog or binary value from the UC/CC
Carrier Text Point	Reading a text string from the UC/CC
Analog - Setpoint Write	Reading and writing individual variables
Demand Limit Load to Shed	I/O points for Demand Limiting

- 1 As you add Elements, enter the requested information for the CCN points:
 - **Display Text** - the description of the point as it appears in the i-Vu® interface (i.e., Pump status)
 - **Reference Base** - the name of the point used when linking the point to a graphic element. All points have a unique identifier (i.e., input_pumpstat, trendPumpstat)
 - **Input Address** - enter the CCN path to link to this point. In the i-Vu® interface, all CCN tables have a **Copy Path** symbol  at the far right of the display. Clicking on this symbol places a copy of the path on the clipboard. In EquipmentBuilder, paste the path into the **Input Address** field, using Ctrl+v.
- 2 When you are finished adding Elements for your application, click **Next**.
- 3 Type a new **Equipment Name**, if desired.
- 4 In **Save Location**, browse to a location where you would like to save the new custom equipment.
- 5 Click **Save**.

Custom graphic

Use ViewBuilder to edit the graphic.

Map to Point procedures for the UC/CC

I/O Points that are included in a custom equipment file are automatically mapped to their associated CCN points once the file is downloaded in the i-Vu® application. The following procedure is not required for those points.

This procedure is necessary to map associated points with the **Setpoint Support** option:

- 1 In the navigation tree, select the UC/CC and click **+** to expand tables.
- 2 Click **+** next to the table headings (**Setpoint, Status Display, Maintenance**, etc.) to see additional tables.
- 3 Select the table you want.
- 4 Click the drop-down list under **Map to Point** in the far right column and select the variable to be mapped.
NOTE Not Mapped erases any previously selected information.
- 5 Click **Accept**. The **Map to Point** entry changes to the mapped point's description.

Create custom equipment files for UC/CC's that link to TPI points

You create an equipment file in **EquipmentBuilder** for the UC/CC, which maps the I/O points required for one or more applications. In this type of equipment, you can link CCN to TPI points in a UC/CC. Once you have created the files, you can associate the linked I/O points with ViewBuilder graphics.

NOTE To have a **Prime Variable**, (a temperature displayed in a color oval when the UC/CC is shown in a site or area equipment list), that comes from a TPI point, you must select the **Link to Third Party to Prime Variable** option when creating the equipment file. You must not select the **Schedule and Setpoint** option for this equipment.

- 1 Start EquipmentBuilder. (Windows **Start > All Programs > I-Vu Tools x.x**)
- 2 Click **Create Equipment**.
- 3 Select **I-Vu ApplicationBuilder**.
- 4 Select equipment type: **Custom Equipment > CCN Link Integration**.
- 5 Click **Next**.
- 6 In **Equipment Name**, type a name for the custom equipment (i.e., Hot Water system).
- 7 Select options from the drop down menus.
- 8 Click **Next**.
- 9 Choose the type of element, quantity and click the .

Add Elements to your application

NOTE Elements are a collection of input/output points that perform a specific operation. The input/output point that is reading or writing to the UC/CC is called a CCN point.

The available Elements that you can add to your custom equipment in EquipmentBuilder are:

Point type	Used for
Read CCN Point	Reading an analog or binary value from the UC/CC
Read Integration Point	Reading an analog or binary value from a TPI
Carrier Text Point	Read a text string from the UC/CC
Analog - Setpoint Write	Reading and writing individual variables
Analog - Link CCN to Integration	Writes CCN variables to TPI
Analog - Link Integration to CCN	Writes TPI variables to CCN
Analog - Link CCN Passive to Integration	Writes CCN variables to TPI
Analog - Link Integration to CCN Passive	Writes TPI variables to CCN
Analog - BACnet Value to CCN	Writes BACnet variable to CCN
Analog - CCN to Integration Setpoint Write	Writes CCN to TPI setpoint

Point type	Used for
Analog - Manual TPI output/setpoint	Manual control from UI to TPI/CCN
Demand Limit Load to Shed	I/O points for Demand Limiting
Binary - Link CCN to Integration	Writes CCN variables to TPI
Binary - Link Integration to CCN	Writes TPI variables to CCN
Binary - Link CCN Passive to Integration	Writes CCN variables to TPI
Binary - Link Integration to CCN Passive	Writes TPI variables to CCN
Binary - Link BACnet Value to CCN	Writes BACnet variable to CCN
Binary - Manual Control	Manual Control from UI to TPI/CCN
Binary - Time Manual Control	Delay on Make Control

- 1 As you add Elements, enter the requested information for the CCN or TPI points:
 - **Display Text** - the description of the point as it appears in the i-Vu® interface (i.e., Pump status)
 - **Reference Base** - the name of the point which is used when linking the point to a graphic element. All points have a unique identifier (i.e.,input_pumpstat, trendPumpstat)
 - **Input Address** - enter the CCN path to link to this point. In the i-Vu® interface, all CCN tables will have a **Copy Path** symbol  at the far right of the display. Click on this symbol to place a copy of the path on the clipboard. In EquipmentBuilder, paste the path into the **Input Address** field, using Ctrl+v.
- 2 When you are finished adding **Elements** for your application, click **Next**.
- 3 Type a new **Equipment Name**, if desired.
- 4 In **Save Location** - browse to a location where you would like to save the new custom equipment.
- 5 Click **Save**.

Custom graphic

Use ViewBuilder to edit the graphic.

Create stand-alone applications

In EquipmentBuilder, you can create some pre-engineered, stand-alone equipment applications with a view for Consumable Reports for Energy Meters (electric, gas, water, steam, generic), non-linear flow meters, energy (BTU) consumption, and equipment runtime.

These options can be added to **CCN Values Only** and **Link Integration** custom equipments. Mapping the points allows monitoring.

NOTES

- 1 meter and 1 Runtime may be added to equipment.
- There is an application for a CCN Vertical Pack unit. This is a CC with special software and BEST++. While this controller can be discovered in the i-Vu® application in **CCN Setup** as a Vertical Pack, none of the possible selected options can be auto-discovered, so only a base view is generated. This application allows you to generate a correct equipment and view file, based on the selected options.

Working with Terminal System Managers

A Terminal System Manager (TSM) that is scanned into the system is assigned an auto-generated equipment that represents Group 1 in the TSM. Group 1 is the default group which can control the setpoints and occupancy for all of the existing zones, or up to 16 specifically selected zones. This equipment is pre-mapped and requires no further action.

All other Groups or Zone equipment must be added as expansion equipments. You must use EquipmentBuilder to create the necessary additional Group or Zone equipment files. These files map the CCN variables to i-Vu® BACnet points and replace the default equipment in the expansion equipments that have been added for the additional Groups or Zones.

Once the equipment files are created and uploaded to the i-Vu® application, these points can be assigned to custom graphic elements, which you create in **ViewBuilder**.

Expansion equipment associated with a TSM must be added to the i-Vu® application on the **Devices** page to support additional Groups and Zones. You must create separate equipment and view files in EquipmentBuilder for each expansion equipment.

Important points when setting up your TSM in the i-Vu® application

- You must add each group or zone as a new equipment.
- TSM's can only be on Bus **0**.
- Only the Gateway can be Bus **0**.
- The Gateway can support 140 devices and 200 equipments
- A fully utilized TSM (12 Groups/64 Zones) takes 76 equipment files.

NOTE If you have 2 TSM's with 8 Groups and 37 Zones in each, it takes 45 equipment files for each TSM, or a total of 90 equipment files from a possible 200. This allows another 110 equipments for every other controller on Bus **0**.

Create custom equipment files in EquipmentBuilder for Terminal System Managers (TSM)

EquipmentBuilder creates .equipment and .view files for the TSM temperature zones and control groups. The .equipment file contains points that you finish formatting in the i-Vu® interface after uploading.

You specify the air source(s) that the TSM communicates with by configuring its Linkage function. A system can consist either of 1 TSM communicating with 1 to 4 air sources, or 1 to 4 TSM's communicating with a single air source.

- 1 Start EquipmentBuilder. (Windows **Start** > **All Programs** > **i-Vu_Tools_x.x**)
- 2 Click **Create Equipment**.
- 3 Select your equipment type:
 - **TSM II Plus Group**
 - **TSM II Plus Zone**
 - **TSM II Group**
 - **TSM II Zone**
- 4 Click **Next**.
- 5 In **Equipment Name**, type a name for the custom equipment (i.e., Hot Water system).
- 6 Enable **English** or **Metric** units.
- 7 Click **Next**.
- 8 Check the files that you want to generate.
- 9 Browse to the desired location to store your files and click **Open**.
- 10 Click **Next**.
- 11 Click **Save**.
- 12 Click **Exit** to close or **Start Over** to create another equipment file.

Custom graphic

Use ViewBuilder to edit the graphic or make a custom graphic.

Assign and download a TSM equipment file in the i-Vu® application

When you scan equipment in the i-Vu® application, each TSM is assigned Group 1. You must:

- Add a new separate equipment for each additional zone and group that you want a graphic for
- Create the .equipment file for each in EquipmentBuilder
- Upload the .equipment and .view file for the new equipment that was added in the i-Vu® application

The group or zone that you create in EquipmentBuilder contains setpoint support, schedules, and a Group or Zone's points configuration. The CCN path information is automatically configured, however, it is incomplete and you must use a **Search and Replace** function to exchange the generic Groups or Zones for your specific Group or Zone number.

To upload an equipment file to a TSM Group or Zone that is already present in the i-Vu® application

- 1 Either double-click the controller in the navigation tree, or right-click and select **Configure** in the list.
- 2 Enter the **Display Name**.
- 3 To add a control program to the list of possible .equipment files in i-Vu®, do one of the following:

If the control program is...

- | | |
|--|---|
| In the Control Program drop-down list | a. Select the control program that you generated in EquipmentBuilder or Snap.
b. Click Accept . |
| Not in the Control Program drop-down list | a. Click Add New .
b. Browse to select the equipment file.
c. Click Open .
d. Click Continue .
e. Click Close .
f. Click Close again. |
-

- 4 To add a graphic, do one of the following:

If the graphic is...

- | | |
|--|--|
| In the Views Available list | a. Select the graphic, then click Attach .
b. Click Accept . |
| Not in the Views Available list | a. Click Add New .
b. Browse to select the view file.
c. Click Open .
d. Click Continue .
e. Click Close .
f. Click Close again. |
-

- 5 When finished, select the Gateway in the navigation tree and select the **Devices** page.
- 6 Click **Download CCN** to finalize your changes.

To add expansion equipment for additional groups and zones controlled by your TSM (expansion controllers)

- 1 In the navigation tree, select the device manager that the controller is associated with.
- 2 Select the **Devices** page and click **Add Control Program**.
- 3 Enter the **Display Name**.
- 4 Select the controller or Gateway that you want to associate the new equipment with. If you select **CCN Controller**, enter the Bus and Element number of the controller.
- 5 Do one of the following:

If the control program is...

- | | |
|--|---|
| In the Control Program drop-down list | <ol style="list-style-type: none">a. Select the control program that you generated in EquipmentBuilder.b. Click Accept. |
| Not in the Control Program drop-down list | <ol style="list-style-type: none">a. Click Add New.b. Browse to select the view file.c. Click Open.d. Click Continue.e. Click Close.f. Click Close again. |
-

- 6 Add a graphic or, if finished, select the Gateway in the navigation tree and, on the **Devices** page, click **Download CCN** to finalize your changes.
- 7 To add a graphic, do one of the following:

If the graphic is...

- | | |
|--|---|
| In the Views Available list | <ol style="list-style-type: none">a. Select the graphic.b. Click Accept. |
| Not in the Views Available list | <ol style="list-style-type: none">a. Click Add New.b. Browse to select the view file.c. Click Open.d. Click Continue.e. Click Close.f. Click Close again. |
-

- 8 When finished, select the Gateway in the navigation tree and, on the **Devices** page, click **Download CCN** to finalize your changes.

Configure the path to the source of the point for TSM Groups and Zones

A generic list of points is created in the i-Vu® application when the TSM Group or Zone is scanned into the system or when you upload the .equipment file.

You must initially revise the address of the path for every point!

- 1 Select the TSM Group or Zone in the navigation tree, then click **Properties > Network Points** tab.
- 2 To substitute the correct Group or Zone number where the double X (XX) is in each path, click the **Search/Replace** button under the **Address** column.
- 3 Enter "XX" in the **Search** field and enter the appropriate Zone or Group number in the **Replace** field. This updates all of the paths for that Zone or Group.

IMPORTANT!

TSM Zone 1 requires an extra step because 1 point has a slightly different name than in Zones 2 thru 64. The setpoint offset point in Zone 1 is inadvertently named **STPOFF**, while it is named **SPTOFF** in the remaining Zones.

This causes an error because the point is incorrectly mapped in the template for Zone 1, even though it is correctly mapped for Zones 2 through 64.

You must change **SPTOFF** to **STPOFF** for this one zone!

Example:

CCN://LINK/TZDSP01/SPTOFFST must be changed to **CCN://LINK/TZDSP01/STPOFFST**.

Integrating third-party data into the i-Vu® system

This feature not available in the i-Vu® Standard application.

You can integrate third-party devices into the i-Vu® Plus system if the following are true:

- The third-party devices are physically connected on the i-Vu® Plus system's network
- You have a Carrier controller that supports third-party integration
- You have the correct Carrier driver for the third-party protocol
- You have enabled a port for a third-party protocol on the Carrier controller's driver page

To read from or write to a third-party device, you need the following information from the third-party vendor:

- Protocol
- Third-party device's network address
- Memory location of the object in the device you want to read from or write to

If you are integrating with BACnet devices, you can use the i-Vu® Plus *BACnet Discovery* (page 128) feature to gather this information.

Before you begin a third-party integration, study the Carrier controller's *Installation and Start-up Guides* and the third-party protocol's *Integration Guide*. Both are available on the Carrier website (<http://www.hvacpartners.com>).

The following Carrier routers let you integrate the allowed number of third-party points into your i-Vu® Plus system:

This router...	Allows this number of non-BACnet third-party points...
i-Vu® Link	500
i-Vu® Open Link	500
Carrier® ChillerVu™	1000
i-Vu® XT BACnet Link	1500

NOTE The point allowance of a router that provides third-party points applies to only itself. For example, if you purchase an i-Vu® Open Link and download control programs that use 125 third-party Network I/O points, you cannot apply the unused 125 points to a different router.

To discover third party BACnet networks, devices, and objects

The i-Vu® **BACnet Discovery** feature locates all accessible BACnet networks, BACnet devices, and BACnet objects (including devices in your i-Vu® system) on a BACnet network. The information gathered in this process is typically used to integrate third-party BACnet devices and their BACnet objects into the i-Vu® system.

To use **BACnet Discovery**:

- 1 Select the System  in the navigation tree and then the **Devices** page > **Advanced** tab.
- 2 Click the **BACnet Discovery Start** button to discover BACnet sites for the system. An item called **Discovered Networks** appears in the tree. After all sites are found, close the status dialog box.
- 3 To discover BACnet networks, select **Discovered Networks**, then click **Go**. A list of all BACnet networks appears in the navigation tree. After all networks are found, close the status dialog box.



TIP Run a commstat manual command to determine which device routes to each network. The **BACnet Blind Show Network** section of the Commstat window shows the IP address of the router to each network.

- 4 To discover BACnet devices on a network, select a network in the navigation tree, then click **Go**. After all devices are found, close the status dialog box. Click  beside an item to expand the list of devices.
- 5 To discover BACnet objects on a device, select the device on the navigation tree, then click **Go**. After all objects are found, close the status dialog box. A list of all BACnet objects in this device appears on the navigation tree.



TIP Make sure you are discovering objects in the correct device. It may take some time to discover objects in devices with more than 100 objects.

- 6 Optional: Do the following to export the BACnet information so that it can be used in the Snap application:
 - a) On the navigation tree, select a discovered network with devices or a single device.
 - b) Click **Export**.
 - c) Name and save the .discovery file in any folder.

NOTES

- Some third-party BACnet devices may not be discovered because they do not support the BACnet methods required for auto discovery.
- If the discovery process returns ambiguous information, such as multiple points with similar names, contact the third-party manufacturer's representative for clarification.
- Device configuration or network load can prevent the i-Vu® interface from showing all BACnet devices. If you do not see a BACnet device that you expect to see, check the system's BBMD configurations. If the configurations are correct, try the discovery process again.

To determine the number of third-party points used in a controller

i-Vu® Pro application only - SiteBuilder

Right-click the controller on the **Network** tree, then select **Run Point Count**.

In the i-Vu® application

- 1 On the navigation tree, right-click the controller.
- 2 Select **Driver Properties** > **Properties** page > **Settings** tab, and then scroll to the bottom of the page.
- 3 **Number of Integration points requested** and **Number of Integration points active** show how many non-BACnet third-party Network I/O microblocks the controller is using. These two counts will differ if you exceed the product's integration point limits. For example, if your control program includes 27 Modbus points, your **Integration points requested** will be 27 and your **Integration points active** will be 25.

To configure LonWorks points using the LonWorks Integration Tool

- 1 Log in to the i-Vu® application.
- 2 Double-click the third party controller in the navigation tree. A dialog window appears.
- 3 Click **Export.erl** under **Integration Points**.
- 4 Click **Save**.
- 5 Browse to a location on your computer to save the file. (The file will have a .erl extension.)
- 6 Start the **LonWorks Integration Tool** (Lonworks_Integration_Tool.jar).



- 7 Click  to start the wizard

- 8 Follow the wizard's instructions to create your LonWorks addresses.



- 9 Click  to save the file to your PC. (The file will be saved with a .erl extension.)

- 10 Return to i-Vu®.
- 11 In the navigation tree, double-click the i-Vu® to open the **Configure** dialog box.
- 12 Navigate to **Integration Points** at the bottom of the screen and click **Import .erl**.
- 13 Browse to the .erl file that you saved in the LonWorks Integration Tool.
- 14 Click **Open** and then **Continue** to upload the file.
- 15 Click **Close**. The LonWorks addresses are now set.

Configuring your system

Work with controllers, set up Linkage, and perform Test and Balance

Refer to your individual controller's *Installation and Start-up Guide* for detailed explanations and procedures on configuration, sequence of operation, and Linkage.

i-Vu® network connection options and requirements

You can use any of the following common network configurations (see below for details):

- **Option 1** - Connect directly from a computer to the i-Vu® web server
- **Option 2** - Connect to the Intranet for internal network access only
- **Option 3** - Connect to the Internet through the Intranet for both internal and external access
- **Option 4** - Connect to the Internet through a dedicated broadband account

Option 1 - Connect directly from a computer to the i-Vu® web server

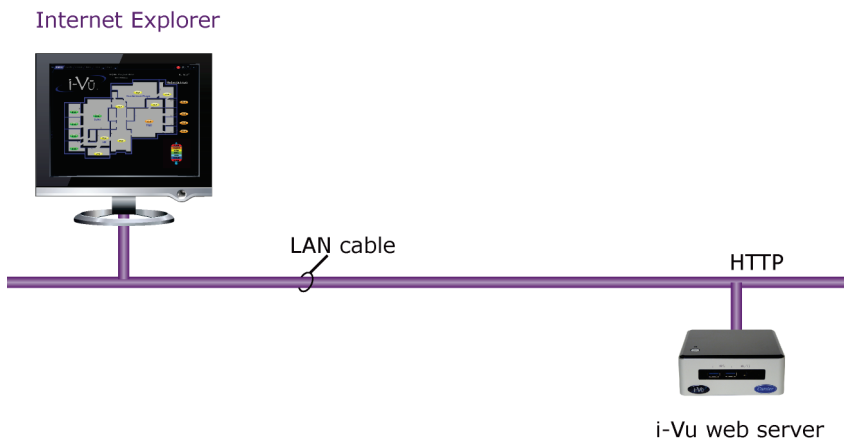

Requirements:

- Windows-based computer with supported web browser and available Ethernet port
- LAN Cable (either straight or crossover)

Email Options - None

Option 2 - Connect to a LAN for internal network access only

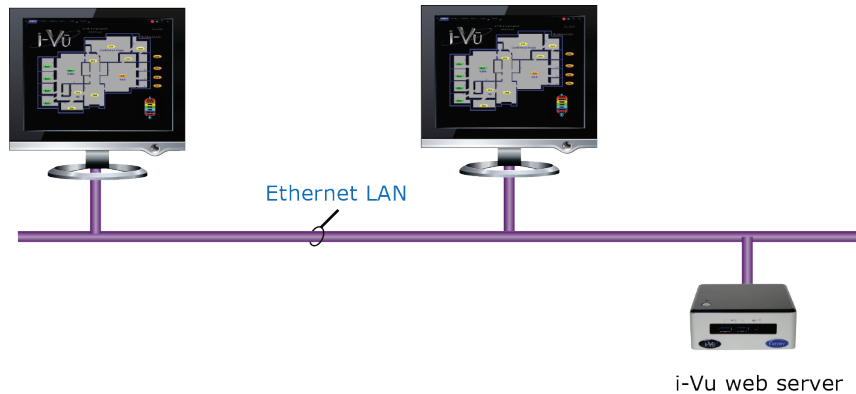

Requirements:

- Windows-based computer with supported web browser and Ethernet port
- Access to Ethernet LAN
- For i-Vu® Standard and Plus systems, you need a (DHCP or static) IP address for each of the following:
 - One IP address for the i-Vu® web server (required)
 - One IP address for the i-Vu® web server's internal router (optional)
 - One IP address for each external i-Vu® router (if applicable)

Email Options - Email can be sent from a local or an Internet mail server if network policies allow this.

Option 3 - Connect to the Internet through an Intranet for both internal and external access

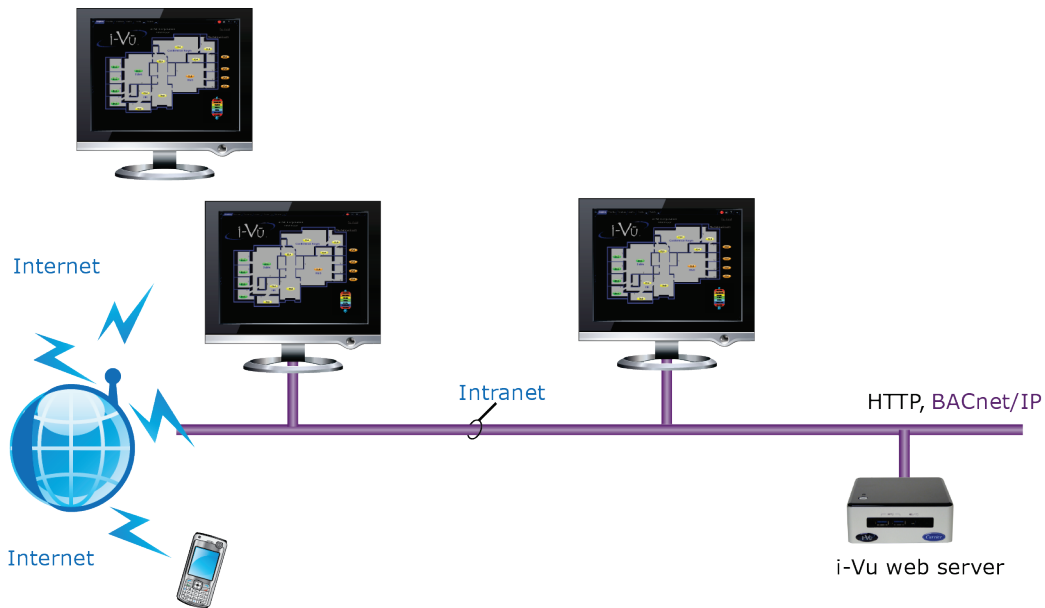

Requirements:

- Windows-based computer with supported web browser and Ethernet port
- Access to Ethernet LAN
- For i-Vu® Standard and Plus systems, you need a (DHCP or static) IP address for each of the following:
 - One IP address for the i-Vu® web server (required)
 - One IP address for the i-Vu® web server's internal router (optional)
 - One IP address for each external i-Vu® router (if applicable)
- Internet IP address provided by the site's IT personnel
- Open firewall port for HTTP/HTTPS traffic to the i-Vu® web server's IP address (default is port 80/443 respectively)

Email Options - Email can be sent from both Internet and Intranet mail servers. To send email off of the LAN, the DNS and domain field must be properly configured in the i-Vu® web server.

Option 4 - Connect to the Internet through a dedicated broadband account



- Window-based computer with supported web browser and Ethernet port
- Broadband Internet connection (internet IP address provided by the Internet Service Provider)
- IP router (w/Integrated Switch if computer or external i-Vu® routers will be used)
- For i-Vu® Standard and Plus systems, you need a (DHCP or static) IP address for each of the following:
 - One IP address for the i-Vu® web server (required)
 - One IP address for the i-Vu® web server's internal router (optional)
 - One IP address for each external i-Vu® router (if applicable)
- Open firewall port for HTTP/HTTPS traffic to the i-Vu® web server's IP address (default is port 80/443 respectively)

Email Options - Email can be sent from a local or an Internet mail server if network policies allow this.

Network security

Your i-Vu® building automation system's controllers and server should be as secure as possible. However, achieving this security can be challenging because of the complexities of networks, firewalls, and virtual private networks (VPN's).

While the i-Vu® server was designed to be secure, BACnet is an open protocol that can pose risks for the controllers. The most secure system is one that is completely isolated from the Internet, but that is not always possible. The v6-02 or later drivers for Carrier controllers with Ethernet capability have a BACnet firewall feature that allows you to restrict communication with the controller to all private IP addresses and/or to a whitelist of IP addresses that you define. To set this up, go to the navigation tree > right-click the router > **Driver Properties** > **Bacnet Firewall**. Follow the instructions in the interface.

For information on secure network configurations, options, and best practices, see the following documents on the Carrier support website.

- *Security Best Practices*
- *Security Letter*

Using a Modstat to troubleshoot your system

A Modstat (Module Status) provides information about a controller and verifies proper network communication with the controller.

To obtain a Modstat

You can get a controller's ModStat in the following places:

- Open device—In the i-Vu® application
- i-Vu® XT device—In the i-Vu® application or the controller's setup pages

In the i-Vu® application

Use one of the following methods:

- Right-click a router or control program in the navigation tree, then select **Module Status**.
- Select a router on the navigation tree. On the **Properties** page, click **Module Status**.

In the controller's setup pages (i-Vu® XT device only)

- 1 Connect an Ethernet cable from a computer to the controller as shown below.

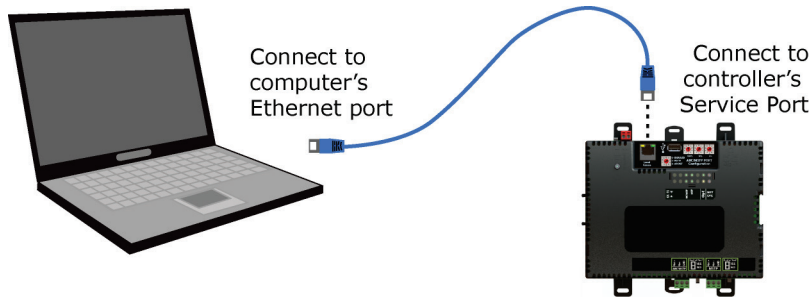

- 2 If your computer uses a static IP address, set the address to 169.254.1.x, where x is 2 or greater. If it uses a DHCP address, leave the address as it is.
- 3 Turn off the computer's Wi-Fi if it is on.
- 4 Open a web browser on the computer.
- 5 Navigate to <http://local.access> or <http://169.254.1.1> to see the controller setup pages.

Modstat field descriptions

NOTE Modstats vary for different types of controllers. The list below describes all information that could appear on any Modstat. If a description differs between different generations of controllers, the generation is noted.

Field	Description
Date/Time	Date and time the Modstat was run
CM	The controller's rotary switch address (MAC address)
Model Name	Identifies the Product Type
Device Instance	A unique ID assigned to the controller
Driver built	When the driver was built
Downloaded by	When and where the last download was performed
Application Software Version	The name of the first control program that is downloaded
Flash Archive Status	Shows the validity, date, and time of the most recent archive of parameters and status to the controller's permanent flash memory. The archive takes place once a day.
# PRGs initialized # PRGs running	If applicable, the number of control programs that were downloaded vs. the number that are running. If these numbers are not the same, the controller has a problem such as lack of memory.
Firmware sections in flash memory	The name, version, and date of the driver

Field	Description
Reset Counters:	<p>Open device: The number of times each of the following events have occurred since the last time the controller was formatted.</p> <p>i-Vu® XT device: The number of times each of the following events have occurred since the last time the controller was commanded to clear the reset counters. See NOTE below this table.</p>
Power failures	Interruption of incoming power
Brownouts	Low-level incoming power
Commanded boots	Includes commands issued from the i-Vu® interface such as the zap manual command, plus commands issued during a memory download.
System errors	Error in the controller's firmware or hardware
Watchdog timeouts	Watchdog is firmware that monitors the firmware for normal operation. If watchdog detects a problem, it restarts the firmware.
S/W Watchdog timeouts	Watchdog is firmware that monitors the application firmware for normal operation. If the watchdog firmware detects a problem, it restarts the application firmware.
H/W Watchdog timeouts	H/W Watchdog will restart the controller if it detects a severe problem with the controller's operating system
System status	Gives the current status of the controller's operation.
Network status	Gives the current status of the controller's networks.
System error message history	<p>Open device: High-severity errors since the last memory download or format. Shows the first 5 and last 5 messages.</p> <p>i-Vu® XT device: High-severity errors since the last memory download. Shows the most recent 10 messages. See NOTE below this table.</p>
Warning message history	<p>Open device: Low-severity errors and warning messages since the last memory download or format. Shows the first 5 and last 5 messages.</p> <p>i-Vu® XT device: Low-severity errors and warning messages since the last memory download. Shows the most recent 10 messages. See NOTE below this table.</p>
Information message history	<p>Open device: Information-only messages since the last memory download or format. Shows the first 5 and last 5 messages.</p> <p>i-Vu® XT device: Information-only messages since the last memory download. Shows the most recent 10 messages. See NOTE below this table.</p>
Manifest revision	Firmware revision
Installed bundles	Components of the firmware

Field	Description
ARC156 reconfigurations during the last hour	An ARCNET network normally reconfigures itself when a controller is added to or taken off the network. The Total field indicates the number of reconfigurations in the last hour. Initiated by this node indicates the number of reconfigurations initiated by this controller. Typical sources of the problem could be this controller, the controller with the next lower rotary switch address, any controller located on the network between these two controllers, or the wiring between these controllers. An excessive number in these fields indicates a problem with the network.
BACnet comm errors in the last 7 days	BACnet communication errors usually indicating dropped packets caused by high traffic on network.
Core (or Main) and Base board hardware	Gives the following information about the controller's boards: <ul style="list-style-type: none"> Type and board numbers that are used internally by Carrier. The manufacture date and serial number. Open device only: The core board's RAM and Flash memory. RAM is used for driver and control program executables. Flash memory is used for firmware and file storage. See Flash storage size below.
Number of BACnet objects	The number of BACnet objects that were created in the device and the number of those objects that are network visible.
Largest free heap space	Size of the largest piece of unused dynamic memory
Database size	Open device: Size of the controller's memory designated for running programs. Database memory is used for control program parameters, status and history; trends, schedules, and alarms; and driver parameters, status and history. i-Vu® XT device: Size of the controller's memory.
Flash storage size	The size of the flash memory that is not used by the firmware. This memory is used for file storage and archiving.
Archive storage size	The amount of flash memory remaining for archival after files are downloaded.
File storage size	The size of all files (control programs, graphics, driver, etc.) downloaded to the controller. How much information is in these files depends on whether the controller's Download source files option is selected in i-Vu®.
Raw physical switches	The readings used to test the DIP or rotary switches
Network Information	Open device: The various network addresses for a controller installed on an Ethernet. The Current and Assigned addresses will be the same unless: <ul style="list-style-type: none"> The Assigned addresses were changed in PuTTY. The controller's DHCP/Assigned DIP switch was moved to the DHCP position after the Assigned addresses were defined. The Enable IP configuration changeover on the BACnet Router Properties page is being implemented. i-Vu® XT device: The various network addresses for the controller. The Current and Assigned addresses will be the same unless the Enable IP configuration changeover on the BACnet Router Properties page is being implemented.
Route Information	BACnet networks that a router is currently routing traffic to. The list changes as BACnet routers are added or removed from the system.

Field	Description
Ethernet statistics	Diagnostic counters directly related to the ethernet communications hardware.

NOTE i-Vu® XT device only—If you want to clear the Reset counters and the three message history fields, click the **Clear Counts/Logs** button on the controller's **Properties** page in the i-Vu® application or in the i-Vu® XT device's setup pages that you access through the Service Port.

Commissioning equipment

Follow the process below to commission system equipment.

Step 1: Check out point setup

- 1 On the i-Vu® navigation tree, select the piece of equipment you want to check out.
- 2 Click **Properties**.
- 3 View and change properties on the **I/O Points, Alarm Sources, Trend Sources, Network Points, BACnet Objects**, and **Rnet Points** tabs. See "Property descriptions" below.
- 4 After completing the equipment checkout, click the **Checkout** tab.
- 5 Select **Checked Out**. This field is for your reference only.
- 6 Optional: Type notes.
 - Notes typed in this field appear in the Equipment Checkout report and can also be changed from the Properties page Notes field for this piece of equipment.
 - Notes remain in this field until an operator deletes them.
- 7 Optional: Click the **Reports** drop-down arrow button, then select and run each of the following reports to verify your work:
 - **Equipment > Point List**
 - **Alarms > Alarm Sources**
 - **Equipment > Trend Usage**
 - **Equipment > Network IO**



TIP You can export the calibrated data so that you can import it into another control program. See *Optional: Import/export calibration data* (page 144).

Property descriptions

I/O Points

Name	Click the name to display the microblock pop-up. NOTE A red name indicates a fault condition where the point may be misconfigured. EXAMPLE No input/output number or a nonexistent input/output number.																								
Type	Type of Input or Output point. See <i>Point types</i> (page 145).																								
Value	The point's present value.																								
Offset	Allows for fine calibration of the present value of an analog point.																								
Polarity	Determines the point's binary normal polarity in the control program. NOTE Polarity is not the hardware normally open/normally closed position.																								
Locked	Select the checkbox to lock the present value at the value you specify.																								
Exp:Num	Expander numbers and input or output numbers associated with where the physical point wires, such as a sensor wire, are physically connected to a controller.																								
I/O Type	Selects the bank of physical inputs or outputs on the controller.																								
Sensor	Selects how the physical input is mapped to the engineering units. Min/Max is used with the sensor type of linear to scale the input to engineering units. NOTE This field is ignored for sensor types other than linear. EXAMPLE: AI																								
	<table border="0"> <tr> <td>linear sensor type</td> <td></td> <td></td> <td></td> </tr> <tr> <td>min</td> <td>-10</td> <td></td> <td></td> </tr> <tr> <td>max</td> <td>50</td> <td></td> <td></td> </tr> <tr> <td>when input reads</td> <td>100%</td> <td>the value is</td> <td>50</td> </tr> <tr> <td></td> <td>50%</td> <td></td> <td>20</td> </tr> <tr> <td></td> <td>0%</td> <td></td> <td>-10</td> </tr> </table>	linear sensor type				min	-10			max	50			when input reads	100%	the value is	50		50%		20		0%		-10
linear sensor type																									
min	-10																								
max	50																								
when input reads	100%	the value is	50																						
	50%		20																						
	0%		-10																						
Actuator	Selects how the present value in engineering units is mapped to the physical output. Min/Max is used with the actuator type of linear to scale the output from engineering units. NOTE This field is ignored for actuator types other than linear. EXAMPLE: AO																								
	<table border="0"> <tr> <td>linear sensor type</td> <td></td> <td></td> <td></td> </tr> <tr> <td>min</td> <td>-10</td> <td></td> <td></td> </tr> <tr> <td>max</td> <td>50</td> <td></td> <td></td> </tr> <tr> <td>when input reads</td> <td>50</td> <td>the output is</td> <td>100%</td> </tr> <tr> <td></td> <td>20</td> <td></td> <td>50%</td> </tr> <tr> <td></td> <td>-10</td> <td></td> <td>0%</td> </tr> </table>	linear sensor type				min	-10			max	50			when input reads	50	the output is	100%		20		50%		-10		0%
linear sensor type																									
min	-10																								
max	50																								
when input reads	50	the output is	100%																						
	20		50%																						
	-10		0%																						
Resolution	Amount by which the present value will change. EXAMPLE If a physical input changes by 1, but the resolution is set at 2, then the present value remains the same. If the input changes by 2, the present value will then change by 2.																								
Checked Out	These fields are for your reference only.																								
Checkout Notes																									

Alarm Sources

Name	Click the name to display the microblock pop-up.
Type	Type of point that is an alarm source. See <i>Point types</i> (page 145).
Alarm	Shows Alarm in red if a current alarm exists.
Network Visible	Select to allow the microblock to be seen by the i-Vu® application and third-party BACnet controllers on the network.
Potential alarm source	Select to enable the microblock to generate alarms.
Alarm Enabled	<p>Alarm—Select to generate an alarm when conditions exceed the limits set in the Condition column.</p> <p>Return—Select to generate a return-to-normal message when the alarm condition returns to a normal state.</p> <p>Fault—Select to have an alarm generated if the alarm source is not configured correctly. For example, a misconfigured channel number produces a no sensor fault.</p>
Requires ack	<p>Alarm—Select to require that the alarm be acknowledged.</p> <p>Return—Select to require that the return-to-normal message be acknowledged.</p>
Critical	Select if the alarm is critical.
Category	You can change the alarm category assigned to the microblock.
Condition	<p>An alarm will be generated if conditions exceed the low or high limits set.</p> <p>Deadband: The amount inside the normal range by which an alarm condition must return before a return-to-normal notification is generated.</p> <p>EXAMPLE</p> <p>High = 225 215</p> <p>10 = Deadband</p> <p>-15 Low = -25</p> <p>10 = Deadband</p> <p>■ Alarm is generated ● Return-to-Normal is generated</p>
Delay	Delay time in seconds for notification after an alarm is generated.

Trend Sources

Name	Click the name to display the microblock pop-up.
	<p>NOTE A red name indicates a fault condition where the point may be misconfigured.</p> <p>EXAMPLE No input/output number or a nonexistent input/output number.</p>
Type	The type of point being trended.
Sample Interval	The interval or COV (Change of Value) increment that triggers the trend sample.
COV Increment	The increment, or interval, that triggers the trend sample on Change of Value

Network Points

Name	Click the name to display the microblock pop-up. NOTE A red name indicates a condition where the point may be misconfigured.
Type	Type of network point.
Value	The point's present value. EXAMPLE For a Maximum point type, Value is the maximum value of all the target BACnet object properties the point is communicating with.
Locked	Select the checkbox to lock the present value at the value you specify.
Default Value	The value that the control program will use as the point's value when communication with the target defined in the Address column is lost or communication is disabled.
Com Enabled	Select to enable this point's network communications. Disable this property for troubleshooting. NOTE Select All in the column header to quickly enable all points in the control program.
COV Enable	Select to make: <ul style="list-style-type: none"> • A digital network output point write a value to the target defined in the Address column only when the value changes. • An analog network output point write a value only when the value changes by the specified increment.
Refresh Time (mm:ss)	The time interval at which the network point writes or retrieves the value to or from the target. For network output points, this time is used when COV is not enabled or when COV is enabled but fails. NOTE If COV fails and the Refresh Time is zero, the value is sent once per second.
Address	The address of the target BACnet object property or third-party value that the point communicates with. NOTE Click Search/Replace at the top of the Address column to have the i-Vu® application replace all instances of specific text in the addresses with different text. This is especially useful when copying a control program to use for multiple third-party devices.
Error	The error code and error if the point cannot communicate with the target.
Present Value	Current value of the target defined in the Address column.
Checked Out	These fields are for your reference only.
Checkout Notes	Notes typed in this field appear in the Equipment Points List Report .

BACnet Objects

Name	Click the name to display the microblock pop-up. NOTE A red name indicates a condition where the point may be misconfigured.
Reference name	A unique identifier that allows the point to be referenced for used for graphics, source tree rules, or network links.
Type	The BACnet object type.

Present Value	The object's current value.
Locked	Check to lock the third-party object to a specific value.
Device	A device alias. See "To reuse a control program" in Device Alias.
Object Name	An alpha-numeric string that is unique within the third-party device.
Object ID	A combination of the object type and a unique instance number. The object ID must be unique within the device.
Address	The address of the third-party object that the microblock references.
Network Visible	Allows other BACnet equipment to read or change the microblock's present value. Must be enabled for this microblock to generate alarms.

Rnet Points

This tab shows varying information for the different point types. Below are all possible properties that may appear on this tab and a list of the applicable points. The following list is arranged alphabetically.

Combination Algorithm	(Analog Sensed Values) The method used to combine the ZS sensors' values to determine the microblock's output value.
Default Value	(Analog Parameters, Binary Parameters, Multi-State Parameters) The value the control program uses until a user changes the value in the system interface.
Display Resolution	(Analog Sensed Values, Analog Statuses, Analog Parameters) Defines the resolution of the value to be displayed on the ZS sensor. For example, 1 displays only integers (example: 74) and 0.5 displays values to the nearest 0.5 (example: 74.5).
Edit Increment	(Analog Parameters) The amount that you want each press of the sensor's ▲ or ▼ button to change the microblock's value.
Editable	(Analog Parameters, Binary Parameters) When enabled, the microblock's value is editable on the ZS sensor.
Lock Present Value to	(Binary Parameters) Check to output the locked value from the microblock instead of the microblock's calculated value.
Maximum	(Analog Parameters) The highest amount that this value can be changed to on the ZS sensor or in the i-Vu® interface.
Menu Configuration	(All points) Shows which sensor screens display the value.
Minimum	(Analog Parameters) The lowest amount that this value can be changed to on the ZS sensor or in the i-Vu® interface.
Minimum off time	(Binary Parameters) The minimum period (seconds) that the microblock sends an off signal to the controller, regardless of the input signal to the microblock.

Minimum on time	(Binary Parameters) The minimum period (seconds) that the microblock sends an on signal to the controller, regardless of the input signal to the microblock.
Object Id	(All points) A combination of the object type and a unique instance number.
Object Name	(All points) A unique alphanumeric string that defines the BACnet object. Although the Object Name field can be edited, it is not recommended.
Reference name	(All points) A unique identifier that allows the point to be referenced for used for graphics, source tree rules, or network links.
Rnet Tag	(All points) Defines what type of information this value represents and determines how the sensor will display the value. For example, for the Rnet Tag Fan Status , the sensor automatically displays  on the Home screen when the microblock is active.
Show on sensors	(Analog Sensed Values) Defines whether the ZS sensors are to display their individual sensed values, or the value determined by the Combination Algorithm .
Type	(All points) Type of Input or Output point.
Value	(All points) The point's present value.

Protocol Mapping

If a control program was built with Protocol Mapping information in Snap, this tab will appear showing third-party protocol configuration information.

Step 2: Check controller communication

- 1 On the navigation tree, select the network that the controller is on.
- 2 On the **Devices** page, view the status of all controllers on that network.



- Navigate to a network or router further down in the tree to show its controllers on the **Devices** page.
- In the **Reports** button drop-down list, select **Network > Equipment Status**, then click **Run** to see the status of all controllers below the selected tree item.

Step 3: Check equipment operation

Refer to the sequences of operation in the system specifications to verify that the equipment operates in each operational mode (for example, occupied and unoccupied) as specified.



TIP If needed, you can import calibration data that you exported from another control program. See *Optional: Import/export calibration data* (page 144).

Step 4: Check the commissioned status

- 1 In the i-Vu® interface, select the system.
- 2 Click the **Reports** drop-down arrow button, then select **Commissioning > Equipment Checkout**.
- 3 Run the report.

Optional: Import/export calibration data

You can export I/O point calibration data from a control program and import it into the same control program or another control program with the same I/O point configuration.

To export calibration data

- 1 On the i-Vu® navigation tree, select the control program whose data you want to export.
- 2 Scroll to the bottom of the **Properties** page **I/O Points** tab, and then click **Export**. The file **<control program name>_<ref name>.xml** is saved in your browser's **Downloads** folder.

To import calibration data

NOTE We recommend that you export existing data as a backup before you import new data.

- 1 On the i-Vu® navigation tree, select the control program that you want to import the data into.
- 2 Scroll to the bottom of the **Properties** page **I/O Points** tab, and then click **Import**.
- 3 Browse to the file you want to import.
- 4 Click **Continue**. A side-by-side comparison of existing data and the new import data will appear. Red text indicates one of the following errors:
 - **Duplicate data**—Existing data has duplicate I/O numbers so that import cannot determine its match.
 - **I/O type mismatch**—I/O Type in existing data does not match I/O Type in import data.
 - **Missing import data**—Existing data has a point that import data does not have.
 - **Missing system data**—Import data has a point that existing data does not have.
- 5 Click **OK** to complete the import. Existing data that does not show an error will be overwritten by the imported data.

Adjust airflow configuration for VAV or VVT controllers

To enter airflow parameters for a VAV Zone, VVT Zone or VVT Bypass controller, right-click on the controller in the navigation tree and select **Airflow Config** in the menu.

For more information, see the following microblock details.

- VAV Zone, VAV Zone II, Zone Ctrl, VAV Zone II Secondary Duct - Airflow Control
- VVT Zone, VVT Zone II - PD Airflow Control
- VVT Bypass, VVT Bypass II - BACnet Bypass Control

Point types

A point name on the Properties page is followed by a code that tells you the point type. The table below describes each code.

Name	Type	Value
<u>Zone Temp Sensor</u> / <u>Zone Temp</u>	(BAI)	? °F ▼
<u>CO2 Sensor</u>	(BAI)	? ▼

Code	Point type
AI	Analog Input
ANI	Analog Network Input
ANI2	Analog Network Input 2
ANO	Analog Network Output
ANO2	Analog Network Output 2
AO	Analog Output
ASVI	BACnet Analog Sensed Value Input
AV	Analog Value
BAI	BACnet Analog Input
BALM	BACnet Alarm
BAO	BACnet Analog Output
BAV	BACnet Analog Value
BBI	BACnet Binary Input
BBO	BACnet Binary Output
BBV	BACnet Binary Value
BFM	Floating Motor
BI	Binary Input

Code	Point type
BMSV	BACnet Multi-State Value
BNI	Binary Network Input
BNI2	Binary Network Input 2
BNO	Binary Network Output
BNO2	Binary Network Output 2
BO	Binary Output
BPTA	Pulse to Analog Input
BPWM	Pulse-Width Output
BRS	RS Sensor
BRSF	RS Sensor Fan
BSVI	BACnet Binary Sensed Value Input
BTLO	Timed Local Override
BTRN	Trend Log
BV	Binary Value
DI	Digital Input
DO	Digital Output
EVT	BACnet Alarm
POLLAVG	Average Analog Properties
POLLMAX	Maximum Analog Properties
POLLMIN	Minimum Analog Properties
POLLTOT	Total Analog Properties
PTA	Pulse to Analog Input
TLO	Timed Local Override

Commissioning equipment using Field Assistant

PREREQUISITES Your controllers have v4.x or later drivers.

To start up and commission a piece of equipment or a network of controllers, you can run Field Assistant on:

- A laptop connected to a controller's or sensor's Local Access port. See Communicating locally with Open devices.
- A laptop connected to a controller's or sensor's Rnet port. See Communicating locally with the i-Vu® XT devices.
- A laptop or computer connected to an IP network if your controllers are communicating on the network.

See Field Assistant Help for information on using Field Assistant.

Providing source files to Field Assistant

Field Assistant requires a controller's source files. Source files include:

- Control programs (.equipment)
- Drivers (.driver)
- Graphics (.view)
- Touchscreen files (.touch)
- BACview® files (.bacview)

To provide Field Assistant with source files, do one of the following:

- *Download source files from the i-Vu® application* (page 147) to the controller so that they can be uploaded in Field Assistant.

NOTES

- All Open PIC's arrive from the factory containing all their source files. They will no longer have the source files if they have been optimized for download in the i-Vu® application and then downloaded.
- To make sure the controller has the source files in it, verify that in the **System Options > General tab > Download** section that **Optimize download for Open PIC controllers** is unchecked (the default) before downloading from the i-Vu® application.
- *Export the source files from the i-Vu® application* (page 148) to a zip file so that they can be imported in Field Assistant. This option exports all source files for all controllers in the i-Vu® system.



TIP If you download source files to a controller, you may still want to export files from the i-Vu® application. Importing the files in Field Assistant reduces the time required to upload the controllers.

If the technician using Field Assistant changes or adds source files, he can get the new source files back to the i-Vu® application by doing one of the following:

- Download the source files to the controller in Field Assistant so that you can *upload the files in the i-Vu® application* (page 148).
- Export the source files from Field Assistant to a zip file so that you can *import the files in the i-Vu® application* (page 148).
This option exports the source files for all controllers in the system to the zip file.

See Field Assistant Help for instructions on uploading, downloading, importing, or exporting source files in Field Assistant.

To download source files from the i-Vu® application

- 1 Click , then select **System Options > General tab > Download** section and verify that **Optimize download for Open PIC controllers** is unchecked (the default setting).
- 2 Select a system or a router on the navigation tree.
- 3 On the **Devices** page, select the controller that you want to download.
NOTE **Shift+click** or **Ctrl+click** to select multiple controllers to download.
- 4 Select **All Content** in the Download drop-down list, then click the **Download** button.

NOTE If a programmable controller does not have enough memory for the files, the download will fail and an error message displays. You must remove or edit the control programs.

To export source files from the i-Vu® application

Export the source files from the i-Vu® application (page 148) to a zip file so that they can be imported in Field Assistant. This option exports all source files for all controllers in the system.

- 1 Click , then select **System Options** > **General** tab > **Source Files** section and click the **Export** button.
- 2 Save to your desired location.

To upload source files to the i-Vu® application

- 1 Select a router in the navigation tree.
- 2 On the **Devices** page, select the controller whose files you want to upload.
NOTE **Shift+click** or **Ctrl+click** to select multiple controllers to upload.
- 3 Select **All Content** in the Upload drop-down list and then click the **Upload** button.

NOTE If an equipment has multiple views attached, the views will be uploaded with a display name of **Default**. To change the names, right-click the equipment in the tree, select **Configure**, then select the view in the **Views** > **Attached** list. The **Display Name** field appears for you to edit.

To import source files in the i-Vu® application

- 1 Click , then select **System Options** > **General** tab > **Source Files** section and click the **Import** button.
- 2 Browse to the ***sourcefiles.zip** file.
- 3 Click **Continue**.
- 4 Click **Close**.

NOTE If the import detects a difference between a database file and an import file with the same name, import does not overwrite the database file. A message lists any file differences so that you can resolve them.

Downloading to controllers

If you make any of the following changes, you must download the new data from the i-Vu® application to the affected controllers.

-
- | | |
|------------------------|--|
| In the i-Vu® interface | <ul style="list-style-type: none">• Change or reload a control program• Change or reload a driver• Change a schedule <p>NOTE A schedule change automatically downloads unless you uncheck Automatically Download Schedules on each change on the My Settings page.</p> <ul style="list-style-type: none">• Change a screen file |
|------------------------|--|
-

The i-Vu® application automatically marks the affected controllers as requiring a download. You can download these controllers from the **Properties** page (page 151) for the controller, the equipment, or a microblock.

When the i-Vu® application marks a controller for download, it determines what information needs to be downloaded based on the type of information that changed. See *Download Options* (page 149).

By default, Full Source files are downloaded to Open PIC controllers because **Optimize download for Open PIC controllers** is unchecked in the **System Options** (or **System Settings**) > **General** tab > **Download** section. If you have multiple sites, you can adjust this for each site individually. Check this option if you do not want Full Source downloaded.



CAUTION If you want this option checked and purposely had it checked in your previous system, it is automatically unchecked after upgrading and you must check it again.

NOTES

- A property change in the i-Vu® interface is automatically downloaded to the controller. If the download fails, the controller is added to the **Downloads** page with the reason for the failure.
- To see who downloaded a controller last, go to the navigation tree, select the controller, then do one of the following:
 - Select **Properties** > **Control Program** > and click the underlined **Controller:** name (Controller 1, Controller 2...) at the top left. This opens the **Controller Information** page, where you click the **Module Status** button.
 - Select **Reports** > **Network** > **Controller Status** and then click **Run**.
 - Right-click the controller in the tree and select **Module Status**.

Download Options

When the i-Vu® application marks a controller for download, it determines what information needs to be downloaded based on the type of information that changed. Below are the options that can be downloaded.

This option...	Downloads...
All Content	<ul style="list-style-type: none"> • The names and executable portion of the driver and control programs • The names and full content of Equipment Touch and BACview® files • The names of any .view files that are marked to be included in a download • Parameters • Schedules <p>NOTE An All Content download also:</p> <ul style="list-style-type: none"> • Synchronizes the controller's time to the i-Vu® web server. • Overwrites trends in the controller. • Restarts the controller.
Only Schedules	All schedules that are not set for automatic download
Only Parameters	All editable properties
Only BBMDs	BBMD tables (.bdt file) that you have updated but have not yet written to the controller

NOTES

- An All Content download clears trend, history, and alarm data from the affected controllers. At the beginning of the download process, trends that have the Trend Historian enabled are saved to the system database.

- If Field Assistant will be used with your system, you can choose to have the **All Content** option download the full source files instead of only their names. See *Commissioning equipment using Field Assistant* (page 146).

To download from the Downloads page

The **Downloads** page shows any controllers that the i-Vu® application marked for download. But if needed, you can add other controllers to the list.

To download:



- 1 On the navigation tree, select an item to download controllers at and below that item.
- 2 Click **Downloads**.
- 3 Click  to the left of a **Location** to see controllers that require a download.
- 4 Optional: To add controllers to the list:
 - a) Click **Add**.
 - b) Select the controller(s).
NOTE Use **Ctrl+click** or **Shift+click** to select multiple controllers.
 - c) Select a *Download Option* (page 149).
 - d) Click **Add**, then click **Close**.
- 5 Select the controllers that you want to download.





NOTES

- Use **Ctrl+click**, **Shift+click**, or the **Select All** checkbox to select multiple controllers.
- A network's controllers download in the order shown. To change the order, select a controller(s), then drag and drop or click **Move to Top** or **Move to Bottom**.
EXCEPTION If a controller's router requires a download, it will download first regardless of its position on the Download page.

- 6 Click **Start**.

NOTES

- Click **Hold** to stop pending  downloads. Active downloads  cannot be stopped.
- Up to 5 routers can download simultaneously.
- A controller is removed from the list when its download is complete.
- Icons in the **Tasks** column indicate the following:

	Active —The i-Vu® application is downloading to the controller.
	Pending —You initiated the download, and the controller is waiting for its turn to download.
	Failed —The download failed. See <i>If a controller fails to download</i> (page 151).
	On Hold —Indicates either of the following: <ul style="list-style-type: none"> • The controller requires a download • You clicked Hold to stop a pending  download.

- Click  in the upper left-hand corner to view a log of download activity in the current session. **Copy to Clipboard** lets you copy the text to paste it into another application.
- To remove an item from the download list, right-click the item, then select **Remove selected tasks**.

To download from a Properties page

If a controller requires a download, a red download message and a **Download** button appear at the top of the **Properties** page for the controller, the equipment, or a microblock. Click the button to start the download.

Downloading from the **Properties** page downloads **All Content** to the controller.

If a controller fails to download

A controller that fails to download appears on the **Downloads** page with this icon .

- 1 Review the reason for the failure:
 - o Hold your cursor over the failed task to see hover text giving the reason.
 - o Click  in the upper left-hand corner of the page to see information on all failed downloads. **Copy to Clipboard** lets you copy the text to paste it into another application.
- 2 Correct the problem that caused the failure.
- 3 Select the controller on the **Downloads** page, then click **Start**.

Create navigation tree for the User view

The navigation tree is a hierarchical representation of the areas or locations at your site and the mechanical equipment in your system.

- 1 Use the **Arrange User View** window in the **Installer** view to add, delete, rename, or move items in your tree. You can also select a system or controller in the tree and right-click to configure change it.

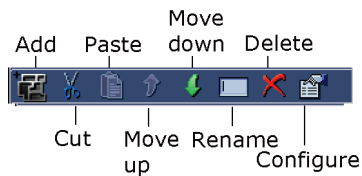

- 2 Right-click on your system name at the top of the tree in the **Arrange User View** window and select **Add Area** (or click  in the toolbar above the navigation tree). Type in the name of an area, location, or building that contains mechanical equipment.
- 3 Repeat the above until all required areas have been added to the navigation tree. The following is an example:

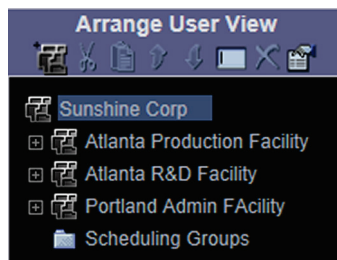

- 4 To move one or more controllers to a specific area, select the icon in the User tree, (use Ctrl+click, Shift+click, or both to select multiple controllers) and:
- Use the **Move Up** or **Move Down** arrows in the toolbar
 - Use **Move Up** or **Move Down** arrows in right-click menu
 - Drag and drop

NOTES

- A user with the **Administrator** role can change the display name in the **User** view by selecting the item in the navigation tree and double-clicking, or right-clicking and selecting **Configure**. The **Installer** must make all other changes.
- In the **Installer** view, click and drag the tab at the top of **Arrange User View** to adjust the height of the window.

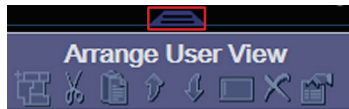

Monitoring and controlling equipment

You can monitor and control your equipment from:

- The Open and i-Vu® XT controller's **Properties (page 41)** pages
- The CCN controller's **Properties (page 41)** pages and the tables that are available when you expand the categories under the controller in the navigation tree
- *The equipment graphic (page 38)* (if applicable)

To lock a BACnet point or value

You can lock certain editable parameters to a specified setting from the **Properties** page or microblock popup.

- 1 Select the **Lock** checkbox.
- 2 Type the value you want to send to the controller.
- 3 Click **Accept**.

NOTE Locked values are indicated by a dashed yellow line on graphics.

On **Properties** page > **Control Program** tab, click  to locate the point you wish to lock.

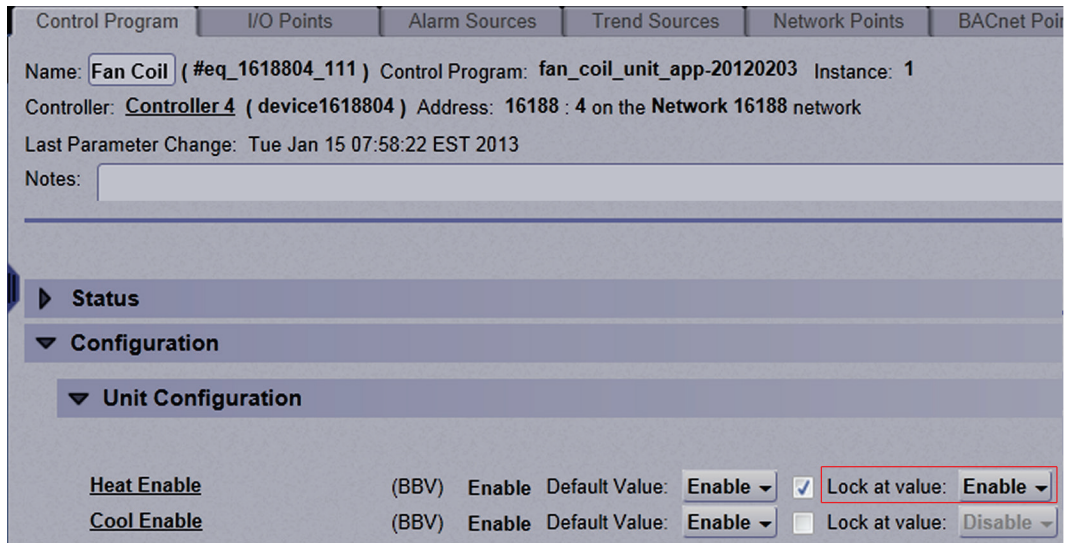

Control Program | I/O Points | Alarm Sources | Trend Sources | Network Points | BACnet Poi

Name: (#eq_1618804_111) Control Program: fan_coil_unit_app-20120203 Instance: 1
Controller: Controller 4 (device1618804) Address: 16188 : 4 on the Network 16188 network
Last Parameter Change: Tue Jan 15 07:58:22 EST 2013
Notes:

▶ Status

▼ Configuration

▼ Unit Configuration

<u>Heat Enable</u>	(BBV) Enable	Default Value: Enable	<input checked="" type="checkbox"/>	Lock at value: Enable
<u>Cool Enable</u>	(BBV) Enable	Default Value: Enable	<input type="checkbox"/>	Lock at value: Disable

On the microblock popup:

1. Click on the underlined **Name** or **Reference Name** of the point on any of the **Properties** tabs to open the microblock popup.
2. Click **Properties** page > **Details** tab to lock a value.



To force a CCN point value

You can force certain editable point values to a specified setting from:

- Equipment tables - click ► next to the equipment to expand tables
- A graphic - hold down Ctrl and, using your mouse, click on the point value on the graphic. A microblock popup appears.
- Properties pages

Forced values are indicated by a dashed yellow line on graphics.

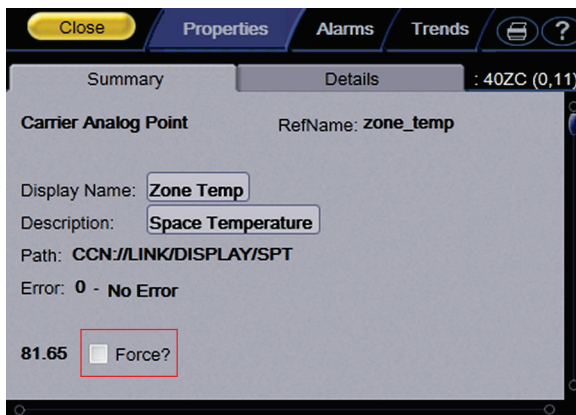

- 1 Select the **Force** checkbox.
- 2 Type the value you want to send to the device.
- 3 Click **Accept** or **Apply**.

To set up peer caching

On the **Devices** page > **Advanced** tab, you can select a **Group Cache Controller** from the drop-down list. Choose the router closest to the i-Vu® server to be the peer caching router. The peer caching router will poll other routers on the IP network for colors and prime variables.

Peer caching also checks the communication status of the peer caching router and any routers for which it is caching. If any of the routers cannot communicate, a Dead Module Timeout alarm is issued.

Working with drivers in the i-Vu® interface

You can make the following changes to a driver in the i-Vu® interface.

- Change or upgrade a driver for controllers. See topic below.
- Routers only:

Reload a driver if it becomes corrupt (for example, a driver page is missing). On the i-Vu® navigation tree, right-click the router or driver, then select **Reload Driver**. Reloading updates all instances of the driver throughout the system and marks the router for an All Content download. Changes you made on the driver pages in i-Vu® remain in effect.

After you make these changes, you must *Download All Content* (page 148) to the affected devices.

To view or change a driver

To view the driver

- In the Installer view, select the router in the navigation tree and select **Devices > Advanced** tab.
- Right-click the controller in the navigation tree and select **Driver Properties**.

To change a driver

- 1 Right-click the controller in the navigation tree and select **Driver Properties**.
- 2 Select the **Properties** page, **Update** tab.
- 3 In the **Controller** section, if other controllers in the system use this driver, select which controllers you want to change.

- This controller only
- All controllers on this network that use same driver version
- All controllers in the system that use same driver version

- 4 Do one of the following:

If the driver is...

- | | |
|---|---|
| In the Driver Version drop-down list | a. Select the driver.
b. Click Accept . |
| Not in the Driver Version drop-down list | a. Click Add .
b. Browse to select the driver.
c. Click Open .
d. Click Continue .
e. Click Close .
f. Click Close again. |
-

- 5 You can continue and also change the screen file, or, if finished, *Download All Content* (page 148) to the controller.
- 6 See *Update the equipment library* (page 162) for details on implementing a new library version of drivers and screen files.



CAUTION Selecting the **Delete Unused** button permanently removes the files from the database.

To change a screen file

- 1 If other controllers in the system use this screen file, select which controllers you want to change.
- 2 Do one of the following:

If the Screen file is...

- | | |
|--|---|
| In the Screen file drop-down list | a. Select the screen file.
b. Click Accept . |
| Not in the Screen file drop-down list | a. Click Add .
b. Browse to select the screen file.
c. Click Open .
d. Click Continue .
e. Click Accept . |
-

- 3 *Download All Content* (page 148) to the controller.

Working with touchscreen or BACview® files in the i-Vu® interface

To use a touchscreen device or BACview® to view or edit a controller's property values, you must download a screen file (.touch, .bacview, .S37, or.kpd) to the controller. The screen file is typically downloaded with the initial download to the controller, but you can select a different file in the i-Vu® interface.

To select a different screen file

- 1 On the i-Vu® navigation tree, right-click the controller, then select **Driver Properties > Update** tab.
- 2 If other controllers in the system use the current screen file, select which controllers you want to change.

- This controller only
- All controllers on this network that use the same screen file
- All controllers in the system that use the same screen file

- 3 Do one of the following:

If the screen file is...

In the **Screen file** drop-down list

- a) Select the file.
- b) Click **Accept**.

Not in the **Screen file** drop-down list

- a) Click **Add**.
 - b) Browse to select the screen file.
 - c) Click **Open**.
 - d) Click **Continue**.
 - e) Click **Close**.
 - f) Click **Close** again.
-

- 4 Download *All Content* (page 148) to the controller.

NOTE You can click **Delete Unused** in the **Screen File** section to delete all unused screen files.

To edit a screen file on an i-Vu® client

On an i-Vu® client, you can get a copy of a screen file from the server, edit it, then put it back on the server.

To get the screen file

- 1 On the i-Vu® navigation tree, right-click the controller that uses the screen file, then select **Driver Properties > Update** tab.
- 2 Under **Screen File**, click **Edit**.
- 3 Click **Save as**.
- 4 Browse to the folder you want to put the file in.
- 5 Click **Save**.
- 6 Click **Close**.

To put the edited file back on the server

- 1 On the i-Vu® navigation tree, right-click the controller that uses the screen file, then select **Driver Properties > Update** tab.
- 2 Under **Screen File**, click **Add**.
- 3 Browse to select the file.
- 4 Click **Open**.
- 5 Click **Continue**.
- 6 Click **Close**.
- 7 Click **Close** again.

System Management

Although the i-Vu® application is a reliable front-end, you must perform periodic backups of the i-Vu® database to ensure a quick recovery in case of failure. To make sure that your controllers have the latest version of software, you must install periodic library upgrades. The sections below describe how to backup and restore the i-Vu® database and how to install the library updates.

Backup data from Management Tool

Access the **Management Tool** using one of the following methods:

- Click , then select **System Options > General tab > Management Tool**.
- Launch your browser and type your system name followed by :8080. For ex.: <http://ivu:8080/>.

Use either of the following methods to backup your data:

Backup data to your computer

- 1 Click **PC Backup** under **Manage Server Data** to save the entire database zipped into one file to your computer.
- 2 Click **OK** when you see the message **The system will be stopped and restarted. Do you wish to proceed?** Watch **Operation Status** to see the progress.
- 3 Click the message **Save/Download Backup File to Your Local Hard drive** when it appears.
- 4 Click **Save** when asked **Do you want to open or save this file?**
- 5 Save this system.backup.tgz file to a convenient location on your computer.
CAUTION! Do not alter the name of this file!
- 6 Exit from **Management Tool**.

Backup data to a USB drive

- 1 Plug your own USB drive into any available USB port on your i-Vu® web server.
 **CAUTION** Do not use the i-Vu® **Restore** USB drive!
- 2 You must reboot in order for the web server to find the USB drive. Click **Reboot** under **Machine Maintenance** in the **Management Tool**.
- 3 Click **OK**.
- 4 When reboot is complete, click **USB Backup** under **Manage Server Data**.
- 5 Click **OK** when you see the message **The system will be stopped and restarted. Do you wish to proceed?**
- 6 When **Operation Status** says **No Background Operations Currently Active**, remove USB drive from the i-Vu® web server.
- 7 Exit from **Management Tool**.

Restore data from backup

- 1 Click **PC Restore** or **USB Restore** under **Manage Server Data** in the **Management Tool**.
 - o **PC Restore** - Browse to your backup file and click **Perform Restore**.
 - o **USB Restore** - Place your backup USB drive in any port on the i-Vu® web server. Select the backup file and click **Perform Restore**.
- 2 Restore is complete when **Operation Status** displays **No Background Operations Currently Active**.
- 3 If you wish to change the name of your i-Vu® system from the default **Ivu**, enter the new name in the **Name** field under **Addressing**. The restore process does not automatically reinstate your previous name.

Restore factory defaults

Restoring factory defaults deletes your existing data and restores your system to factory defaults. This restore process is quicker than using the **Restore** CD or **Restore** USB drive.

- 1 Access the **Management Tool** in **System Options** > **General** tab > **Management Tool** or via your browser by typing your system name followed by :8080.
For ex.: http://ivu:8080.
- 2 Click **Factory Defaults**. This deletes all server data and resets the device to the original factory default values.
- 3 **NOTE** Executing this option will not delete configuration data under the **Addressing** and **I-Vu Port Configuration** sections of the Management Tool.
- 4 Begin setting up your system.

Restore i-Vu® system

From i-Vu® Restore USB drive:

 **CAUTION!** Placing the **Restore** USB drive in the i-Vu® web server USB port reformats your system and restores it to factory defaults. Library updates are lost and you must reapply them.

- 1 Insert the Restore USB drive into any i-Vu® web server USB port.
- 2 Shut down
 - o i-Vu® web server - Shut down the web server by pushing the On/Off button on the top.
 - o Older i-Vu® web server - Shut down the web server by holding down the On/Off button for several seconds. Then wait for the blue lights to go out before restarting.
- 3 Press the On/Off button again to restart. The restore process starts automatically and takes several minutes. The web server shuts off when finished.
NOTE Do not turn the power off during reformatting!
- 4 Wait another minute or two before accessing the new system using a browser.

The following applies only to the older i-Vu® web server model

From i-Vu® Restore CD:

 **CAUTION!** Placing the **Restore** CD in the i-Vu® disk drive reformats your system and restores it to factory defaults. Library updates are lost and you must reapply them.

- 1 Remove the i-Vu® web server from the network by disconnecting the LAN cable.
- 2 Insert the i-Vu® **Restore CD** into the i-Vu® web server CD drive.
- 3 Shut down the i-Vu® web server by pushing the On/Off button **once**. Wait for the blue light to turn off (could take as long as 2 minutes).
- 4 Press the On/Off button again to restart the web server. The installation begins automatically.
- 5 The **Restore CD** ejects when the installation is complete. This process takes several minutes.
NOTE Do not power off during the installation.
- 6 Wait another minute or two before accessing the new system using Internet Explorer.

Update the SAL library

The i-Vu® SAL files update your i-Vu® controllers. The SAL libraries contain control programs, graphics, drivers, screen files, and other important controller data.

Carrier periodically provides updates, which include enhancements and bug fixes.

NOTES

- The library update only changes **default** graphics. If you have edited your graphic in ViewBuilder, it is not updated.
- The last digits in the SAL library name are the release date of the library.
- All of the SAL files will not necessarily have the same <date> revision.
- To ensure that your installation is running the latest software, we recommend that you check *Control Systems Support* <http://www.hvacpartners.com/> for updates. Download the latest SAL files and apply them to all new installations.
- If you are changing to an older SAL file than the current one being used, a warning asks you if you are sure you want to apply an older version.

NOTE Keep copies of the latest libraries in a safe place. In the event of a system restore, the updated .sal file must be reapplied.

To check current SAL library version

- 1 Login to the i-Vu® application.
- 2 Click , then select **System Options > Update** tab.
- 3 Click **Current Libraries (.sal)** to view the current SAL libraries and their revision date.

Step 1: Update library

- 1 Save the updated library (.sal file) to your computer.
- 2 Click , then select **System Options > Update** tab.

NOTE Expand **Current Libraries (.sal)** to see the current SAL libraries and their revision. Compare them to what you downloaded from the *Control Systems Support* (<http://www.hvacpartners.com>) to determine if any of them have been updated.

- 3 Click  and browse to the updated .sal file that you have saved on your computer, select the file, and click **Open**.
- 4 Click **Continue**.
- 5 When process is complete, the message appears **File added successfully**.
- 6 Click **Close**.

NOTE These changes are not applied to the controllers until you have updated routers and controllers.

Follow these steps to implement the new equipment library:

Step 2: Update the files for the routers

- 1 Select the router that you wish to update in the navigation tree.
- 2 Right-click and select **Driver Properties**.
- 3 Select **Properties** page > **Update** tab.
- 4 If the database contains two or more routers, you must check **Change for all controllers of this type?** in the **Controller** section.
- 5 Click **Update**. A message appears **Changes the driver and screen file to use the current library version. Continue?**
NOTE If more than one router exists, the additional routers are listed below the **Update** button.
- 6 Click **OK**.
- 7 Click **Accept**.

Step 3: Update the files for the controllers

- 1 Double-click the controller in the navigation tree or right-click and select **Configure**.
- 2 If you have multiple controllers of the same type, enable **Change for all control programs of this type?**
- 3 Click **Update** under **Control Program**. A message appears **Changes the control program, view, driver, and screen file to use the current library version. Continue?**
- 4 Click **OK**. When the message **Updated to the library version xx.** appears, click **Close**.
- 5 Repeat steps 1 - 4 for any additional types of controllers.
- 6 Click **Close** again.

Step 4: Update the files for CCN controllers

- 1 In the navigation tree, select the CCN device manager associated with the controllers that are to be updated.
- 2 Select **Devices > CCN Discovery** and re-scan any controllers that need to be updated by checking **Rescan Controllers Selected Below for Configuration Changes** and clicking **Start Scan**.

Step 5: Apply the update to the routers and controllers

- 1 Select the **System**  in the navigation tree and then select the **Downloads** page.
- 2 If you wish to apply the new SAL file to your entire system, you can use this page to compare to your navigation tree and verify that you have selected all of your routers and controllers for download.

NOTE Only the CCN Gateway and device managers require download, so the CCN controllers/equipment will not be listed.

- 3 A network's controllers download in the order shown. To change the order, select a controller(s), then drag and drop or click **Move to Top** or **Move to Bottom**.

EXCEPTION If a controller's router requires a download, it will download first regardless of its position on the Downloads page. Click the **Start** button.

NOTES

- Use **Ctrl+click**, **Shift+click**, or the **Select All** checkbox to select multiple controllers.
- See *To download from the Downloads page* (page 150) in Help for more details.

Synchronize to system time

To update all routers and controllers to the system time:

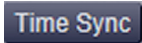
- 1 Click , then select **System Options > General** tab.
- 2 Click  to immediately synchronize all controllers.
- 3 To adjust the time when controllers are automatically synchronized each day, click **Enable time synchronization of controllers daily at** and fill in time.

Advanced topics

Troubleshooting and communications

Troubleshooting BACnet bindings

Every controller has a Device Binding Table that contains all Device IDs that the controller communicates with and the network address of each device. This typically includes the Device ID of the BACnet Alarm Recipient.

If the i-Vu® application is not receiving alarms/trends or if the a point's value is incorrect, you can view this table to see where the controller is looking for its data.

- 1 On the i-Vu® navigation tree, select the router that has incorrect or missing data.
- 2 On the **Properties** page, click the **Show Bindings** button.

Communicating using PuTTY

You can connect a computer to a controller's Local Access port and then use PuTTY, a free open source terminal emulation program, to:

- Set the baud rate for ports S1 on the i-Vu® Open Router, i-Vu® Open Link, or Carrier® ChillerVu™
- Set controller properties, such as IP address and network information
- Retrieve a *Modstat* (page 134)

NOTE Use Network Service Tool V to set the CCN baud rate and configure IP settings for an i-Vu® CCN Router, i-Vu® Link, or Carrier® ChillerVu™.

PREREQUISITES

- A computer with a USB port
- A USB Link cable
The USB Link driver is installed with an i-Vu® v5 or later system. But if needed, you can get the latest driver from <http://www.silabs.com/products/mcu/Pages/USBtoUARTBridgeVCPDrivers.aspx>. Install the driver before you connect the USB Link to your computer.



CAUTION If multiple controllers share power but polarity was not maintained when they were wired, the difference between the controller's ground and the computer's AC power ground could damage the USB Link and the controller. If you are not sure of the wiring polarity, use a USB isolator between the computer and the USB Link. Purchase a USB isolator online from a third-party manufacturer.

- 1 Download and install PuTTY from the *PuTTY website* (<http://www.chiark.greenend.org.uk/~sgtatham/putty/download.html>).
- 2 Connect the laptop to the local access port of the controller, ZS sensor, or an SPT sensor using the USB Link cable(s).

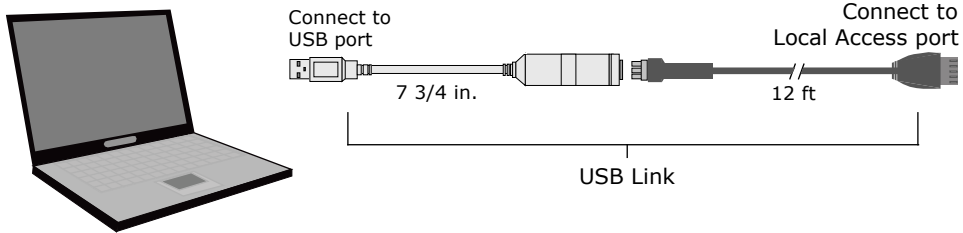

NOTE If using a USB isolator, plug the isolator into your computer's USB port, and then plug the USB Link cable into the isolator.

- 3 To change a router's IP address, subnet mask, or default gateway, set its **IP Address** DIP switch to **Assigned**.
- 4 Start PuTTY.
- 5 Under **Category > Connection**, select **Serial**.
- 6 Under **Options controlling local serial lines**, enter the following settings:

Field	Value
Serial line to connect to	Replace X with the computer's port number that the USB Link cable is connected to. NOTE To find the port number, select Start > Control Panel > System > Device Manager > Ports (Com & LPT) . The COM port number is beside Silicon Labs CP210x USB to UART Bridge .
Speed (baud)	115200
Data Bits	8
Stop Bits	1
Parity	None
Flow Control	None

- 7 Click **Open**. A window similar to the one below appears.

```

1) Restart
2) Display Modstat
3) IP Address [192.168.1.6]
4) Subnet Mask [255.255.255.0]
5) Default Gateway [0.0.0.0]

```

- 8 Do one of the following:
 - o To change a property value:
 - a. Type the number of the property, then press **Enter**.
 - b. Type the new value, then press **Enter**.
 - o To take an action, type number of the action, then press **Enter**.
- 9 If you changed a value, type 1, then press **Enter** to restart the controller.
- 10 Close PuTTY.

Communicating using HyperTerminal

You can connect a computer to a controller's Local Access port and then use HyperTerminal, an application installed with Windows XP and older operating systems, to:

- Set the baud rate for ports S1 or S2 on the i-Vu® Open Router or i-Vu® Open Link
- Set controller properties, such as IP address and network information
- Retrieve a *Modstat* (page 134)

NOTE Use Network Service Tool V to set the CCN baud rate and configure IP settings for an i-Vu® CCN Router or i-Vu® Link, or Carrier® ChillerVu™.

PREREQUISITES

- A computer with a USB port
- A USB Link cable

NOTE The USB Link driver is installed with an i-Vu® v5 or later system. But if needed, you can get the latest driver from <http://www.silabs.com/products/mcu/Pages/USBtoUARTBridgeVCPDrivers.aspx>. Install the driver before you connect the USB Link to your computer.

CAUTION If multiple controllers share power but polarity was not maintained when they were wired, the difference between the controller's ground and the computer's AC power ground could damage the USB Link and the controller. If you are not sure of the wiring polarity, use a USB isolator between the computer and the USB Link. Purchase a USB isolator online from a third-party manufacturer.

- 1 Connect the computer to the local access port of the controller, ZS sensor, or an SPT sensor using the USB Link cable(s).

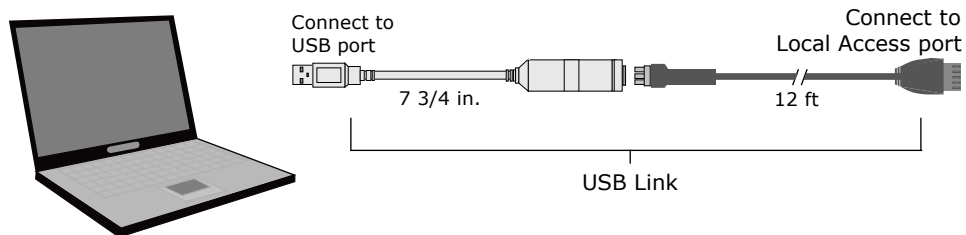

NOTE If using a USB isolator, plug the isolator into your computer's USB port, and then plug the USB Link cable into the isolator.

- 2 Verify that the baud rate is set to 115,200.
- 3 To change a router's IP address, subnet mask, or default gateway, set its **IP Address** DIP switch to **Assigned**.
- 4 Start Windows HyperTerminal located under **Start > Programs > Accessories > Communications**.
- 5 **NOTE** This option is not available in Windows v7 or later. You can download it from the Internet.
- 6 Select an icon for this connection file, then click **OK**.
- 7 In the **Connect to** dialog box, set the **Connect using** field to **ComX**, where **X** is the number of the computer's Com port that the USB Link cable is connected to, then click **OK**.
- 8 In the **Com Properties** dialog box, set the **Port Settings** for your local access port, then click **OK**.

Port Setting	Value
Bits per second	i-Vu® Open Link i-Vu® Open Router i-Vu® Link i-Vu® CCN Router Carrier® ChillerVu™ 115200
Data Bits	8
Parity	None
Stop Bits	1
Flow Control	None

- 9 From the main HyperTerminal screen, press **Enter** to view a router configuration screen like the one below.

```

BACnet Router, Ethernet MAC address = 00-E0-C9-00-4E-B8
1) Restart
2) Display Modstat
3) IP Address [192.168.168.1]
4) Subnet Mask [255.255.255.0]
5) Default Gateway [0.0.0.0]
6) BACnet/IP UDP Port [0xBAC0]
7) BACnet/IP Network [4824+1]
8) BACnet/Ethernet Network [4829]
9) BACnet/ARCNET Network [4825]
10) BACnet/MSTP Network [4834]
11) Display B/IP PAD Table
12) Add B/IP PAD Table Entry
13) Delete B/IP PAD Table Entry
14) Clear B/IP PAD Table
15) Set baud rate for MSTP [76800]
16) Set baud rate for PTP [38400]

+ The HOME network is updated each time a network number
  is changed (#7-10).

Enter selection: _

```

- 10 Do one of the following:
 - o To change a property value:
 - a. Type the number of the property, then press **Enter**.
 - b. Type the new value, then press **Enter**.
 - o To take an action, type number of the action, then press **Enter**.

- 11 If you changed a value, type 1, then press **Enter** to restart the controller.
- 12 Close HyperTerminal.

Troubleshooting networks

If a controller is not communicating, click the router on the i-Vu® navigation tree, then click **Devices**. This page shows the communication status of all controllers on the network. If all controllers on the network are not communicating, you have a network problem. Begin moving up the tree, checking communication status at each level to determine the starting point of the communications problems.

Manual commands

To run a manual command:

- 1 Click  and then select **Manual Command**.
- 2 Type the manual command in the dialog box, then click **OK**.



TIP **Ctrl+Shift+M** also opens the dialog box.

You must have the Installer or Admin role to access the manual commands dialog box. Some commands are restricted to the Installer role only.

Command	Description
addon	Opens a dialog box where you can upload, start, stop, or remove an add-on program such as Tenant Override Billing.
bacnet showindex	Displays all files (file name, size, date) downloaded to the selected controller.
bbmd commands:	You must have the Installer Role to run bbmd commands.
bbmd read <IP address>	<p>Reads the BBMD table of the controller at the given IP address.</p> <p>For example, to display the BBMD table in the BACnet device router at IP address 154.16.12.101, type:</p> <pre>bbmd read 154.16.12.101</pre>
bbmd update <network number>	<p>Selects BBMDs on the specified network and marks them for download. If no network is entered at the end of the command, all networks in the system are scanned.</p> <p>For example, if the network number is 888, type:</p> <pre>bbmd update 888</pre>

Command	Description
bbmd view <network number>	Views the list of BBMDs that have been selected for the network number at the end of the command. Assumes the update has been run. For example: <pre>bbmd view 888</pre>
bbmd write <table file> <IP address>	Writes the BBMD table into the controller at the given IP address. For example, to write the BBMD table in dallasbbmd.bdt into the BACnet device router at IP address 154.16.12.101, type: <pre>bbmd write dallasbbmd.bdt 154.16.12.101</pre>
bbmd clear <IP address>	Clears the BBMD for the specified controller. For example: <pre>bbmd clear 154.16.12.101</pre>
bbmd dump <network> <file>	Writes to a file the BBMD from the specified controller. For example: <pre>bbmd dump 888 dallasbbmd.bdt</pre>
checkurls	<ol style="list-style-type: none"> 1 Finds all network point exp: expressions for the selected item on the navigation tree. 2 Converts the exp: expressions to bacnet:// equivalent expressions that the controllers use. 3 Compares the equivalent bacnet:// expressions to the bacnet:// expressions currently downloaded in the controllers. 4 Displays any mismatches.
checkurls -p	Does the same as checkurls, then adds any mismatches to the download queue as parameter downloads.
checkurls -v	Does the same as checkurls, but displays the exp: and bacnet:// expressions for all network points that were checked.
commstat	Gives a complete set of diagnostic information for all defined connections as well as information regarding all modems in the system.
copy	Displays a global copy utility that allows you to selectively copy trend graphs, custom reports and all editable properties from the selected equipment to other equipment in the system with the same control program. See <i>To use Global Copy</i> (page 46).
download commands:	Each of these commands performs an immediate download to a controller for the selected control program, device, or driver.
download m	Downloads all content, including parameters, schedules, and BBMDs (if applicable).
download p	Downloads parameters only.
download s	Downloads schedules only.

Command	Description
go commands:	
go <refname or path>	Goes to the point in the system that is referenced. For example: go #oa_conditions or go vav_1/m28
go ~network	Takes you to the network the selected object's controller is associated to.
go -logicpopup <refname>	Goes to the microblock pop-up for the microblock that is referenced. You must run this command from the microblock's equipment on the navigation tree. For example: go -logicpopup rs
go <device ID>/<object ID>	Goes to a device and object on the navigation tree. For example: go 300550/AI:3
go <object ID>	Goes to an object for the current device on the navigation tree. For example, if a module alarm reports a control program Locked I/O Alarm and references an error in program 11, click the link to go to the device, then go to the object by typing: go PRG:11
localhost	Shows the IP address of the i-Vu® web server
logoffuser	Logs off a user (without warning the user). Type a <code>whoson</code> manual command to view the IDs of logged in operators, then type <code>logoffuser x</code> , where x is the user's ID.
markdown commands:	
markdownload	These commands place the controller for the selected tree item on the list to download at a later time. The download list can be viewed at the System level on the Downloads page.
markdownload	Marks for an All Content download, that includes parameters, schedules, and BBMDs (if applicable).
markdownload p	Marks for a Parameters download.
markdownload s	Marks for a Schedules download.
memory	Shows the amount of server memory allocated for the i-Vu® application and the amount being used.
memory -free	Releases unused server memory, then shows the i-Vu® memory usage before and after the release.

Command	Description
modstat commands:	These commands display a <i>Modstat</i> (page 134) report. NOTE It is not necessary to download a controller before running a Modstat on it. Binding takes place when you run the modstat.
modstat	Displays status of the controller at the current location, including: <ul style="list-style-type: none"> • Hardware components of the device • Software components of the device • Error conditions that may exist in the device • Date and time the device is using
modstat 8:<device instance number>	Displays status for a specific controller in the IP network using the controller's ID. Your location in the system does not have to be the controller you are querying. For example: <pre>modstat 8:489202</pre>
modstat mac:<network number>,<media type>:<mac address>	Displays a Modstat for a specific controller in the system using the controller's MAC address. Network number is the number of the network this controller is on; media type is the type of network the controller is on; MAC address can be either the controller address or the IP address and depends on the controller's media type. Media types allowed are: <ul style="list-style-type: none"> • bacnet/ip or b • ms/tp or m • ethernet or e For example: <pre>modstat mac:48161,arcnet:2</pre> or <pre>modstat mac:888,bacnet/ip: 172.16.101.119</pre>
notify	Sends a message to all operators currently logged in to the system. For example, "The server is going to shut down in 5 minutes. Please log off." To run this command, type: <code>notify <your message></code> . The message must use only alphanumeric characters. You must have the Installer role to run this command.
paramupload	Uploads parameters (editable properties) to the i-Vu® application from the equipment or driver at the current location and below. If you want to upload editable properties for all equipment under a particular router, navigate to the router or the network on the navigation tree. You must have the Installer role to run this command.
ping	Ping to verify communication between IP devices. You cannot ping devices on non-IP networks. To run this command type: <code>ping <hostname></code> where <hostname> is the IP address or device name. For example: <pre>ping 192.168.168.1</pre> (will ping the IP address 4 times)

Command	Description
rebootserver	Restarts the i-Vu® application. You must log back in to the i-Vu® interface if you want to continue. You must have the Admin or Installer role to run this command.
rebuild	Rebuilds a Properties page. If you make changes to control program property text in the Snap application, navigate to a control program in the i-Vu® tree, and then run this command to see your changes.
reload	Reloads a control program. Use if you make changes to control program in the Snap application. Reloading updates all instances of the control program throughout the system and marks the controller(s) for download. The i-Vu® application determines the type of download based on what changed in the control program. You must have the Installer role to run this command.
restartmodule	Restarts the current controller. You must have the Installer role to run this command.
revert	Resets the selected driver or control program to its default values.
setdefault	Sets the current page as the default view for the selected action button and the selected tree location. You must have the Installer role to run this command.
shutdown	Shuts down the i-Vu Server application. This stops communication between the server and the client, but does not close any open i-Vu® pages. You must have the Admin or Installer role (System Shutdown privilege) to run this command.
storetrends	Uploads trend data from the controller(s) to the database for all equipment at and below the selected item on the navigation tree. This command stores trend data for points that have Trend Historian enabled.
timesync	Synchronizes the time on all controllers at the current location and below to the time on the server. Run this command only from a location on the navigation tree. You must have the Installer role to run this command. NOTE For CNN networks, executing a timesync on a controller sends the timesync to its Gateway, and all the controllers under that Gateway.
whereami	Displays the full path for the current location and gives the display and reference names of the action button, category, instance and tab. If the selected tree location differs from the location shown in the action pane (for example, a point trend page), whereami returns information on both locations. Use this command when you create links in ViewBuilder.
whoson	Shows the list of users currently logged in to the i-Vu® system, the IP addresses from where they are logged on, what kind of interface they are using (for example, lvl5 for a web browser on a computer), and how long it has been since they have actively interfaced with the i-Vu® system.
zap	Restarts the current controller. You must have the Installer role to run this command.

Using DEBUG MODE

DEBUG MODE saves considerable time when troubleshooting custom control programs for programmable controllers. Typical operating mode in the i-Vu® application always downloads full source, which is time-consuming. While operating in DEBUG MODE, Full Source is kept in the database and is not downloaded to the controller.



CAUTION Never leave your i-Vu® system without unchecking DEBUG MODE first and then downloading all content. The source files are not in the controller until you complete both steps.

To use DEBUG MODE

- 1 Select the custom control program in the navigation tree and either double-click it or right-click and select **Configure**.
- 2 Check **DEBUG MODE**.
- 3 Download the new or edited control program. See *Working with control programs* (page 110).
- 4 Before logging out or switching to a different controller, select the control program in the navigation tree and either double-click it or right-click and select **Configure**.
- 5 Uncheck **DEBUG MODE**.
- 6 Download All Content from the **Downloads** page, **Devices** page > **Manage** tab, or any page that has a **Download** button.

Defining i-Vu® paths

A path tells the i-Vu® application the route through the system hierarchy to an item in the system. For example, a path tells the i-Vu® application where to find a microblock property value to display on a graphic or where to jump to when the operator clicks a link on a graphic.

In ViewBuilder, you use paths in:

- Controls
- Links
- Conditional expressions

In i-Vu®, you use paths in :

- The *source field code* (page 83) in alarm actions and messages
- An *Equipment Values report* (page 104)
- The *go manual command* (page 169)
- i-Vu® Pro only: Autopilot

You can do one of the following to get the path:

- In ViewBuilder, let ViewBuilder write the path.
- In the i-Vu® interface, *determine the path yourself* (page 176).

A path consists of the reference name of each tree item included in the path, separated by a forward slash (/). For example, *first_floor/zone_1/rs*.

A path can be *absolute* (page 175) or *relative* (page 175).

i-Vu® paths are based on parent-child hierarchy.

Absolute path

An absolute path begins at a specific point in the system hierarchy and is followed by the children below it down to the object or property of interest. An absolute path can begin with either of the following:

- A global reference name—a reference name that is unique within the entire system and begins with a # sign.
EXAMPLE If OA Conditions has a global reference name of #oa_conditions, the absolute path to OA Conditions is simply **#oa_conditions**. The absolute path to any child of OA Conditions, such as OA Temperature, begins with #oa_conditions. For example, **#oa_conditions/oa_temp**.
- The top of the i-Vu® tree.

Relative path

A relative path is useful for items such as graphics or alarm messages that you will reuse in multiple i-Vu® locations because the path is relative to the item that contains the path.

A relative path going down the tree

A relative path going down the tree begins with the reference name of the item below the location where the path is used. Examples using the system shown above:

- To display the Lobby's zone temperature on the Lobby's graphic, the path is **rs**.
- To display the Lobby's zone temperature on the Atlanta-R&D Facility graphic, the path is **first_floor/zone_1/rs**.

A relative path going up the tree

A relative path going up the tree begins with a ~ followed by one of the options below:

Use...	To go...	Examples using the system shown above
~parent	Up one level	<ol style="list-style-type: none">1 To put a link on the Lobby graphic that goes to the First Floor graphic, the path is ~parent.2 To put a link on the Lobby graphic that goes to the Atlanta R&D Facility (up 2 levels), the path is ~parent/~parent.3 To display the Lobby's zone temperature on the Boiler graphic, the path is ~parent/~parent/first_floor/zone_1/rs/present_value.
~equipment	To the microblock's control program	To display the Lobby zone temperature in a High Temp alarm message, the path is ~equipment/rs/present_value .
~device	From a control program to its device	To show the device name on an equipment graphic, use ~device.display-name .

Determining a path or microblock property

A path tells the i-Vu® application the route through the system hierarchy to an item in the system. Paths are used in graphics, links, alarm messages, alarm actions, network microblock address, and other items.

To get the path to an area, equipment, or microblock

In the i-Vu® interface, right-click the item on the tree, then select **Copy Path**. Paste the path where you need it.

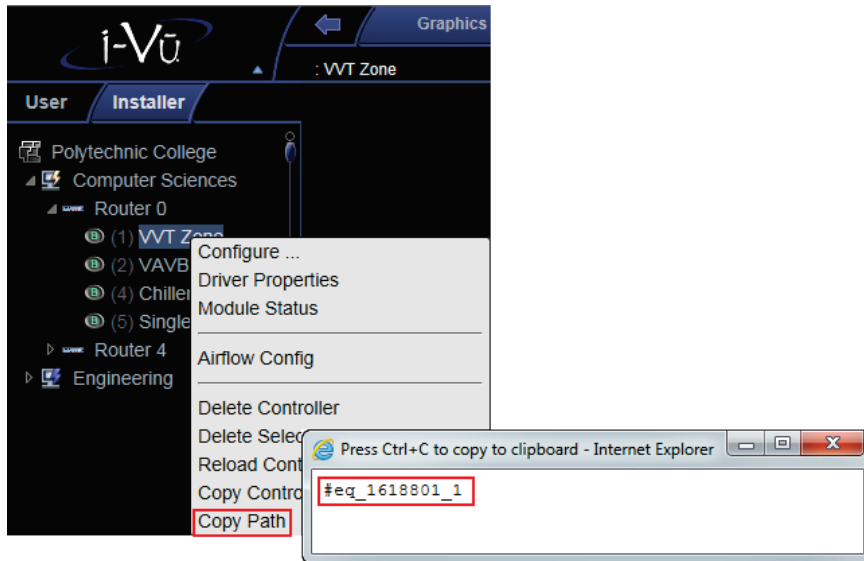

To get the path to a microblock property value

- 1 In the i-Vu® interface, right-click the value, then select **Global Modify**.
- 2 Click **Show Advanced** to see the full path to the property value.

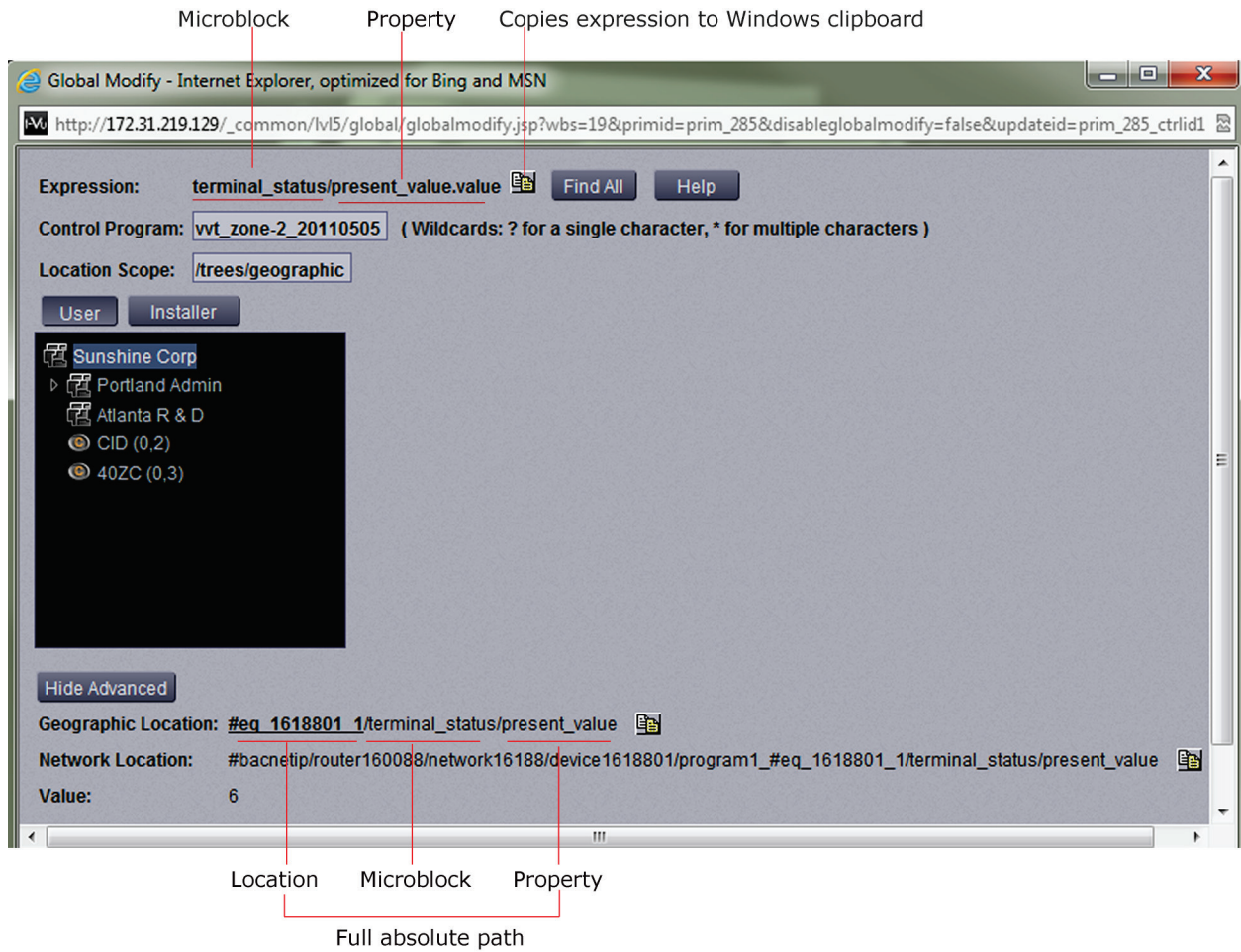

Document revision history

Important changes to this document are listed below. Minor changes such as typographical or formatting errors are not listed.

Date	Topic	Change description	Code*
8/15/18	What's new in the i-Vu® Standard/Plus application	Custom reports – Changed wording in first paragraph.	C-TS-RD-E
8/13/18	Formatting field codes	The example for "To format a number" in the table stated "To always truncate a setpoint value...". Changed to "To always round a setpoint value...".	X-O-JD-E

* For internal use only



CARRIER CORPORATION ©2018

A member of the United Technologies Corporation family · Stock symbol UTX · Catalog No. 11-808-680-01 · 8/15/2018